

**Air quality**  
Enjoy a pure environment



**Airkcool**<sup>®</sup>

Efficiency Air Conditioning Spain

# Customized Air Handling Systems

Catálogo Unidades Terminales FCU  
*Terminal Units Catalogue FCU*



**Dimatek**<sup>®</sup>  
DIMATEK COMFORT SOLUTIONS, S.L.

Air quality  
Enjoy the silence



© Dimatek&Airkcool 2024 ALL RIGHTS RESERVED. PROPRIETARY DOCUMENT

# HydroSystem

**Air quality**  
Enjoy the silence



2024



# DF XE-S

**Fan coil units**  
**Ventilconvettori**

# Dimatek®

DIMATEK COMFORT SOLUTIONS, S.L.

## GUIA PRODUCTO

## PRODUCT GUIDE

# 2024



# Sistemi

# Idronici

appartamenti extralusso, ville di prestigio, uffici direzionali, ecc.)

- Per applicazioni dove la silenziosità è un dovere (es. sale registrazioni, sale radiofoniche, teatri, laboratori, biblioteche, sale di studio, case di cura, ecc.)
  - Per applicazioni "per sé", quando ci si vuol fare un regalo
- Motore elettrico AC, asincrono monofase a gabbia di scoiattolo, provvisto di protettore termico TH (Klixon), condensatore di marcia sempre inserito, 4 poli, IP42, Classe B, doppio isolamento, 230Vac-1Ph-50/60Hz.
- Motore monovelocità + Autotrasformatore a 6 uscite/velocità ben equipaziate (con prestazioni da max=100% a min=40-50%). Autotrasformatore installato all'esterno della spalla dell'unità, per facilitare eventuali operazioni di manutenzione e sostituzione. Questa tecnologia garantisce una enorme flessibilità del prodotto, lasciando all'utente la possibilità di connettere in cantiere qualsiasi velocità selezionabile fra le 6 disponibili, a seconda delle necessità. Su richiesta (senza sovrapprezzo) cablaggio di qualsiasi tema di velocità desiderata.
- Motore silenziato, Condensatore ridotto, Rimodulazione velocità su range ridotto (precablaggio in azienda delle 3 velocità V4,5,6, con 1=Max e 6=Min)
  - Isolamento termoacustico & antivibrante rinforzato (interno, sull'intera unità)
  - Attento collaudo con equilibratura grado 4 + range accettabilità vibrazioni e rumore ridotto

Serie **FXE** 

#### Fandeck con Motore elettronico EC-Brushless + Inverter

Motore tecnologia BLAC (Brushless Alternating Current) a magneti permanenti, senza spazzole, sensor less, 2 protettori (TP-termico/Klixon + EP-elettronico/SW), IP40, Classe B, doppio isolamento, 230Vac-1Ph-50/60Hz.

Motore HEE (High Energy Efficiency motor) ad elevato risparmio energetico (oltre il 50%) e conseguente riduzione CO2 (amico dell'ambiente).

Regolazione modulante con segnale 0...10Vdc tramite i nostri comandi o tramite sistemi di regolazione indipendenti (del cliente): La modulazione 0-100% della portata aria (e conseguentemente della potenza termica e frigorifera), permette di adeguare le prestazioni, istante per istante, alle effettive esigenze del locale da climatizzare, garantendo Comfort totale e riduzione della rumorosità.

Inverter con Dip-switch per settare diversi tipi di Firmware di controllo del motore + Dip-switch per rimodulare il campo di lavoro su un nuovo range più limitato (da 0...10Vdc a 0...6,5Vdc) + Contatto pulito di allarme.

Serie **FXE-P** 

#### Motore elettronico EC-Brushless, rinforzato, Inverter settato con FW-HP (firmware curva Qa-ESP ad alta prevalenza e maggiore RPM), con Contatto pulito di allarme

Motore tecnologia BLAC (Brushless Alternating Current) a magneti permanenti, senza spazzole, sensor less, 2 protettori (TP-termico/Klixon + EP-elettronico/SW), IP40, Classe B, doppio isolamento, 230Vac-1Ph-50/60Hz.

Motore HEE (High Energy Efficiency motor) ad elevato risparmio energetico (oltre il 50%) e conseguente riduzione CO2 (amico dell'ambiente).

Regolazione modulante con segnale 0...10Vdc tramite i nostri comandi o tramite sistemi di regolazione indipendenti (del cliente): La modulazione 0-100% della portata aria (e conseguentemente della potenza termica e frigorifera), permette di adeguare le prestazioni, istante per istante, alle effettive esigenze del locale da climatizzare, garantendo Comfort totale e riduzione della rumorosità.

Serie **FXE-S** 

#### I Supersilenziosi EC: Prodotto dedicato a tutti quei clienti che vogliono godersi la climatizzazione senza rinunciare ad un ineguagliabile comfort acustico

Prodotto appositamente progettato con obiettivo "Minimizzare Livello Sonoro":

- Per applicazioni dove la silenziosità è un valore (es. camere da letto, Hotel 5stelle, appartamenti extralusso, ville di prestigio, uffici direzionali, ecc.)
- Per applicazioni dove la silenziosità è un dovere (es. sale registrazioni, sale radiofoniche, teatri, laboratori, biblioteche, sale di studio, case di cura, ecc.)
- Per applicazioni "per sé", quando ci si vuol fare un regalo

Motore elettronico EC-Brushless, Tecnologia BLAC (Brushless Alternating Current) a magneti permanenti, senza spazzole, sensor less, 2 protettori (TP-termico/Klixon + EP-elettronico/SW), IP40, Classe B, doppio isolamento, 230Vac-1Ph-50/60Hz.

Motore HEE (High Energy Efficiency motor) ad elevato risparmio energetico (oltre il 50%) e conseguente riduzione CO2 (amico dell'ambiente).

Regolazione modulante con segnale 0...10Vdc tramite i nostri comandi o tramite sistemi di regolazione indipendenti (del cliente): La modulazione 0-100% della portata aria (e conseguentemente della potenza termica e frigorifera), permette di adeguare le prestazioni, istante per istante, alle effettive esigenze del locale da climatizzare, garantendo Comfort totale e riduzione della rumorosità.

Inverter con Dip-switch per settare diversi tipi di Firmware di controllo del motore + Dip-switch per rimodulare il campo di lavoro su diversi range di segnale (da 0...10Vdc a 0...6,5Vdc) + Contatto pulito di allarme.

- Motore silenziato, Inverter settato con FW-SIL (firmware con RPM controllata) e Rimodulazione segnale su range ridotto
- Isolamento termoacustico & antivibrante rinforzato (interno, sull'intera unità)
- Attento collaudo con equilibratura grado 4 + range accettabilità vibrazioni e rumore ridotto

Serie **FXE+** 

#### ALTISSIMA EFFICIENZA, ECOSOSTENIBILE, PRESTAZIONI INEGUAGLIABILI, TOP DI GAMMA, Motore elettronico EC-BRUSHLESS PLUS con AXI-Tecnology

Risultato di un progetto internazionale finalizzato a ricerche Ecosostenibili, trova sintesi in un motore con Statore e Rotore a Dischi affiancati (sohili, con magneti permanenti e bobine di eccitazione affiancate) calettati nella mezzera del ventilatore, eliminando qualsiasi ostruzione e deviazione alle linee di flusso aria e riducendo drasticamente qualsiasi possibilità di vibrazione/rumore.

Risultato eccezionale ed ineguagliabile: rispetto ad un EC classico, oltre ad un incredibile risparmio energetico, a parità di RPM (e dunque a parità di rumore)

flats, extra-luxury villas, executive offices, etc.)

- For installations where silence is a must (e.g. recording rooms, radio rooms, theatres, laboratories, libraries, nursing homes, etc.)
  - For "ourselves" installation, when we want to make ourselves a gift
- AC electric motor, asynchronous single-phase squirrel cage, provided with heat protection TH (Klixon), running capacitor permanently switched on, 4 poles, IP42, Class B, double insulation, 230Vac-1Ph-50/60Hz.
- Single-speed motor + Autotransformer with 6 equi-spaced outputs/speed (with performances from max=100% to min=40-50%). Autotransformer is installed externally, on the unit side, to enable easy maintenance operations.
- This technology guarantees big flexibility, with possible connections according to the specific end-user needs, higher or lower speeds selectable upon 6 available.
- On request (no extra cost), different speed can be connected.
- Silenced motor, Reduced condenser, Re-modulated speed on a reduced range (pre-wired at the factory of 3 different speed V4,5,6, where 1=Max e 6=Min)
  - Thermal-acoustic & antivibration insulation reinforced (internal, on the whole unit)
  - Careful testing with 4th balancing degree + reduced vibration and noise acceptance range

#### Fan-deck with EC-Brushless electronic motor + Inverter

BLAC Technology (Brushless Alternating Current) motor, with permanent magnets, brush less, sensor less, 2 protections (TP-thermal/Klixon + EP-electronic/SW), IP40, Class B, double insulation, 230Vac-1Ph-50/60Hz.

HEE motor (High Energy Efficiency motor) with high efficiency (over 50%) and consequent CO2 reduction (environment friendly).

Modulating regulation with 0...10Vdc signal with our control panel or with independent regulation system (by client): The modulation 0-100% of the air flow (and consequently of the heating and cooling capacity), allows to adapt the performances, instant to instant, to the actual needs of the room to be conditioned, warranting total comfort and noise level reduction.

Inverter with Dip-switches to set different types of motor's control firmware + Dip-switches to re-modulate the working field on new limited range (up 0...10Vdc to 0...6,5Vdc) + Alarm dry contact.

#### Reinforced EC-Brushless electronic motor, Inverter setting with FW-HP (firmware Qa-ESP curve with high static pressure and higher RPM), with Alarm dry contact

BLAC Technology (Brushless Alternating Current) motor, with permanent magnets, brush less, sensor less, 2 protections (TP-thermal/Klixon + EP-electronic/SW), IP40, Class B, double insulation, 230Vac-1Ph-50/60Hz.

HEE motor (High Energy Efficiency motor) with high efficiency (over 50%) and consequent CO2 reduction (environment friendly).

Modulating regulation with 0...10Vdc signal with our control panel or with independent regulation system (by client): The modulation 0-100% of the air flow (and consequently of the heating and cooling capacity), allows to adapt the performances, instant to instant, to the actual needs of the room to be conditioned, warranting total comfort and noise level reduction.

#### The Super-silent EC: Product dedicated to all the customers that want to enjoy air conditioning without sacrificing an incomparable acoustic comfort

Product specially designed with the target to "Minimize the Sound Level":

- For installations where silence is a value (e.g. bedrooms, 5 Stars Hotels, extra-luxury flats, extra-luxury villas, executive offices, etc.)
- For installations where silence is a must (e.g. recording rooms, radio rooms, theatres, laboratories, libraries, nursing homes, etc.)
- For "ourselves" installation, when we want to make ourselves a gift

EC-Brushless electronic motor, BLAC Technology (Brushless Alternating Current), with permanent magnets, brush less, sensor less, 2 protections (TP-thermal/Klixon + EP-electronic/SW), IP40, Class B, double insulation, 230Vac-1Ph-50/60Hz.

HEE motor (High Energy Efficiency motor) with high efficiency (over 50%) and consequent CO2 reduction (environment friendly).

Modulating regulation with 0...10Vdc signal with our control panel or with independent regulation system (by client): The modulation 0-100% of the air flow (and consequently of the heating and cooling capacity), allows to adapt the performances, instant to instant, to the actual needs of the room to be conditioned, warranting total comfort and noise level reduction.

Inverter with Dip-switches to set different types of motor's control firmware + Dip-switches to re-modulate the working field on different limited range (up 0...10Vdc to 0...6,5Vdc) + Alarm dry contact.

- Silenced motor, Inverter set with FW-SIL (firmware with controlled RPM) and re-modulated signal on reduced range
- Thermal-acoustic & antivibration insulation reinforced (internal, on the whole unit)
- Careful testing with 4th balancing degree + reduced vibration and noise acceptance range

#### VERY HIGH EFFICIENCY, ECO-SUSTAINABLE, INCOMPARABLE PERFORMANCES, TOP OF RANGE, EC-BRUSHLESS PLUS electronic motor with AXI-Tecnology

Result of an international project aimed to eco-sustainable research, its synthesised in a motor with side by side Stator and Rotor discs (slim, with permanent magnets and facing excitation coils) keyed in the fan centre line, eliminating any obstruction and deviation to the air flow lines and drastically reducing any possible vibration/noise.

Extraordinary and incomparable result: compared to a classic EC, in addition to an incredible energy saving, at same RPM (and therefore at same noise level), it guarantees a higher airflow and static pressure (+20%), vice-versa at same air flow and

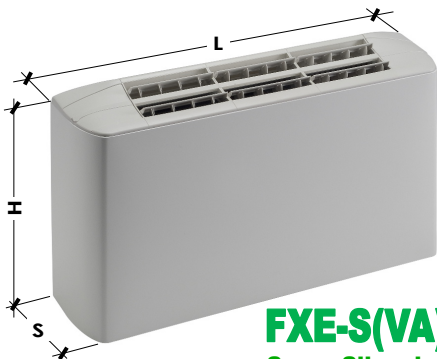

**FXE-S(VA)**  
**Super Silencioso**

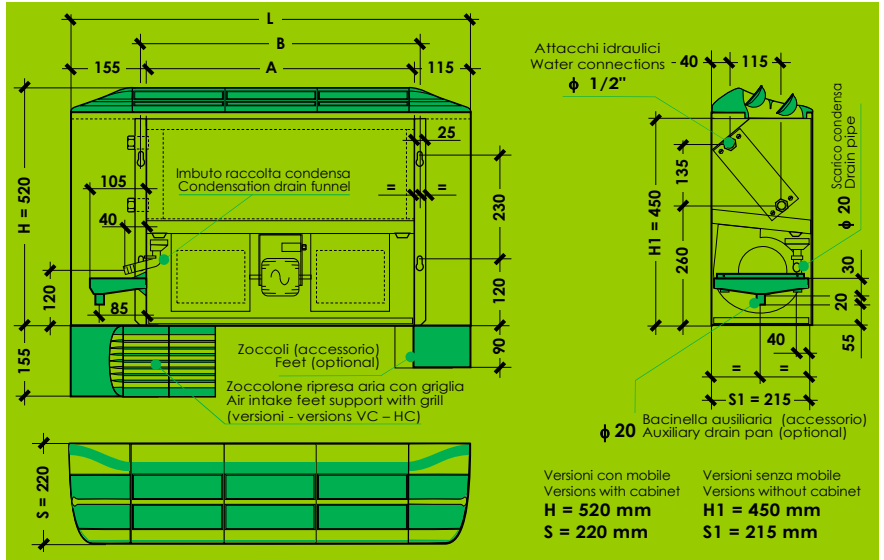

Versioni con mobile Versions with cabinet  
**H = 520 mm**  
**S = 220 mm**

Versioni senza mobile Versions without cabinet  
**H1 = 450 mm**  
**S1 = 215 mm**

Taglia - Size	DF-XE-S	130S	230S	330S	430S	530S	630S	730S	830S	930S	1030S	1130S	1230S
Potenz. Frigorifera Totale - Total (1) W		1.430	1.910	2.380	2.820	3.600	4.070	5.230	6.080	6.860	8.240	8.780	9.790
Cooling capacity Sensibile - Sensible (1) W		1.220	1.540	1.920	2.130	2.740	3.070	4.070	4.510	5.090	5.960	6.890	7.540
Potenzialità Termica - Heating capacity (2) W		3.540	4.670	5.580	6.220	7.800	9.010	11.320	12.540	14.030	16.430	19.200	21.100
Portata aria nominale - Nominal Air flow (3) m³/h		<b>340</b>	<b>370</b>	<b>450</b>	<b>490</b>	<b>625</b>	<b>670</b>	<b>915</b>	<b>960</b>	<b>1.100</b>	<b>1.130</b>	<b>1.655</b>	<b>1.680</b>
Portata acqua Raffred. - Cooling l/h		246	329	409	485	619	700	900	1.046	1.180	1.417	1.510	1.684
Water flow (4) Riscald. - Heating l/h		304	402	480	535	671	775	974	1.078	1.207	1.413	1.651	1.815
Perdite di carico acqua Raffred. - Cooling kPa		11,9	14,9	16,3	18,1	20,8	22,1	22,0	24,3	23,9	24,4	25,9	27,9
Water pressure drops (5) Riscald. - Heating kPa		14,2	17,3	17,5	17,1	19,1	21,1	20,1	20,2	19,5	18,9	24,2	25,3
Livelli sonori - Sound levels (6) Min-Med-Max dB(A)		<10-17-30	<10-18-31	<10-22-34	10-22-36	11-21-30	12-22-31	11-26-35	12-28-36	<10-27-39	10-28-40	11-30-40	12-31-41
Ref. FAN-DECK		SWP/STD.1/7, SWD/STD.1/7		SWP/STD.1/7, SWD/STD.1/7		SWP/STD.1/7, SWD/STD.1/7		SWP/STD.1/8, SWD/STD.1/8		SWP/STD.1/9, SWD/STD.1/9		SWP/FIX.1/10, SWD/FIXD2.1/10	
Motori/Ventilatori - Motors/Fans No./No.		1/1		1/1		1/2		1/2		1/2		1/3	
Assorb. elettrico nominale (Targa) MAX(7) W		55W		65W		85W		90W		90W		180W	
Nominal current input (Label) MAX(7) A		0,35A		0,45A		0,55A		0,55A		0,55A		1,40A	
<b>Alimentazione elettrica - Power supply</b>		<b>230Vac-1Ph-50/60Hz (Signal 0...10Vdc)</b>											
Batteria caldo/freddo Contenuto acqua - Water volume (l)		0,69	0,70	0,99	1,01	1,30	1,31	1,60	1,62	1,91	1,92	2,21	2,23
Heating/cooling coil [Ranghij], DN(*) - [Rows], DN(*)		[3R], 1/2" F		[3R], 1/2" F		[3R], 1/2" F		[3R], 1/2" F		[3R], 1/2" F		[3R], 1/2" F	
Scarico condensa - Drain pipe φ (mm)		20		20		20		20		20		20	
Dimensioni principali Main dimensions	L mm	670		870		1.070		1.270		1.470		1.670	
	H mm	470		470		470		470		470		470	
	S mm	220		220		220		220		220		220	
	A mm	400		600		800		1.000		1.200		1.400	
B mm	425		625		825		1.025		1.225		1.425		
Limite funzionam. inferiore Lower working limit	<b>LFI</b>	10V	1,00	1,00	1,00	1,00	1,00	1,00	1,00	1,00	1,00	1,00	1,00
	<b>ESP = 0 Pa</b>	Med	0,66	0,66	0,66	0,66	0,70	0,70	0,66	0,66	0,63	0,63	0,64
<b>(8) RIDUZIONE PORTATA ARIA</b> Coeff. che delimitano le curve "Portata Aria / Pressione statica" (alle 3 velocità Max-Med-Min) <b>AIR FLOW REDUCTION</b> Coefficients defining the "Air flow / Static pressure" Diagr.(at 3 speed Max-Med-Min)	<b>15 Pa</b>	10V	0,92	0,92	0,92	0,92	0,90	0,90	0,90	0,90	0,92	0,92	0,95
		Med	0,61	0,61	0,61	0,61	0,63	0,63	0,59	0,59	0,58	0,58	0,61
		1V	0,30	0,30	0,29	0,29	0,36	0,36	0,29	0,29	0,23	0,23	0,26
	<b>30 Pa</b>	10V	0,82	0,82	0,83	0,83	0,79	0,79	0,79	0,79	0,82	0,82	0,88
		Med	0,54	0,54	0,55	0,55	0,55	0,55	0,52	0,52	0,51	0,51	0,57
		1V	0,27	0,27	0,26	0,26	0,32	0,32	0,26	0,26	0,21	0,21	0,25
<b>45 Pa</b>	10V	0,67	0,67	0,71	0,71	0,65	0,65	0,67	0,67	0,69	0,69	0,81	
	Med	0,45	0,45	0,47	0,47	0,46	0,46	0,44	0,44	0,43	0,43	0,52	
	1V	0,22	0,22	0,22	0,22	0,26	0,26	0,21	0,21	0,18	0,18	0,22	
<b>(10V-Med-1V = Max-Med-Min)</b> <b>LFS</b> Limite funzionam. superiore Upper working limit	<b>ESP (Pa)</b>	10V	72 Pa	72 Pa	79 Pa	80 Pa	85 Pa	85 Pa	86 Pa	86 Pa	83 Pa	83 Pa	107 Pa
	<b>Qa (x m³/h)</b>		x 0,20	x 0,20	x 0,20	x 0,20	x 0,20	x 0,20	x 0,20	x 0,20	x 0,20	x 0,20	x 0,20
	<b>ESP (Pa)</b>	Med	68 Pa	68 Pa	77 Pa	77 Pa	80 Pa	80 Pa	79 Pa	79 Pa	76 Pa	76 Pa	100 Pa
	<b>Qa (x m³/h)</b>		x 0,19	x 0,19	x 0,20	x 0,20	x 0,19	x 0,19	x 0,19	x 0,19	x 0,19	x 0,19	x 0,19
	<b>ESP (Pa)</b>	1V	55 Pa	55 Pa	61 Pa	61 Pa	66 Pa	66 Pa	60 Pa	60 Pa	52 Pa	52 Pa	73 Pa
	<b>Qa (x m³/h)</b>		x 0,17	x 0,17	x 0,17	x 0,17	x 0,18	x 0,18	x 0,17	x 0,17	x 0,16	x 0,16	x 0,17

**(9) RIDUZIONE POTENZIALITÀ FRIGORIFERA/TERMICA (in funzione della riduzione portata aria)**  
**COOLING/HEATING CAPACITY REDUCTION (depending on air flow reduction)**

Portata aria - Air flow	1,00	0,95	0,90	0,85	0,80	0,75	0,70	0,65	0,60	0,55	0,50	0,45	0,40	0,35	0,30	0,25	0,20	0,15
Potenz. Frigorifera Totale - Total	<b>1,00</b>	0,97	0,95	0,92	0,89	0,87	0,84	0,81	0,77	0,74	0,71	0,67	0,63	0,59	0,55	0,50	0,45	0,39
Cooling capacity Sensibile - Sensible	<b>1,00</b>	0,97	0,93	0,90	0,86	0,83	0,79	0,76	0,72	0,68	0,64	0,60	0,55	0,51	0,46	0,41	0,35	0,29
Potenz. termica - Heating capacity	<b>1,00</b>	0,97	0,94	0,91	0,87	0,84	0,81	0,77	0,74	0,70	0,66	0,62	0,58	0,53	0,49	0,44	0,38	0,32

DN(\*) = Diametro nominale, F = Attacchi idraulici batteria gas femmina

DN(\*) = Nominal diameter, F = Female gas water coil connections

Dati tecnici riferiti alle seguenti condizioni: Unità Standard - Pressione atmosferica 1013 mbar - Alimentazione elettrica 230Vac/1Ph/50Hz.  
(1) (2) (3) (4) (5): Dati tecnici nominali, (1) portata aria nom. (3) Vmax=10V, ESP=0, batteria occlusa → Per le prestazioni (1) (2) alla portata aria di funzionamento riferita a 8+9 o al SW.  
(1) Raffreddamento: Temp. aria 20°C s. - 19°C u.s. - Temp. acqua ingresso/uscita 7/12°C - Portata aria nominale (3). Per le portate aria di funzionamento (es. alle diverse velocità, Segnal. ESP) vedi (8)+(9); rif. acqua ingr. 7°C a portata acqua nominale (4). Raccomandato uso del SW.  
(2) Riscaldamento: Temp. aria 20°C - Temp. acqua ingresso/uscita 70/60°C - Portata aria nominale (3). Per le portate aria di funzionamento (es. alle diverse velocità, Segnal. ESP) vedi (8)+(9); rif. acqua ingr. 70°C a portata acqua nominale (4). Raccomandato uso del SW.  
(3) (2) (9) Rete Frigorifera e Termiche: Valori calcolati da SW e dati rilevati in camera climatometrica rif. norme UNI 7940 parte 1°-2°, UNI-EN 1397/2001.  
(3) (8) Portata aria e Press. statica: Valori nominali rilevati con cassone rif. norme AMCA210-74 fig.12 e condotto + diaframma rif. norme CNR-UNI10023.  
(6) Livelli sonori: Pressione sonora in campo libero, distanza 2 m. Valori calcolati da potenza sonora rilevata in camera invertebrante rif. norme ISO 3741 - ISO 3742.  
(7) Dati elettrici: Valori rilevati con Wattmetro Jokogawa WT10 (Valore max. nominale, di tarso motore = valore di riferimento per progettazione impianto elettrico). Per gli assorbimenti elettrici in funzionamento, classi efficienza energetica, ecc. vedi paragrafo "Tab Regolamento UE-2016-2281".

Technical data refer to the following conditions: Standard unit - Atmospheric pressure 1013 mbar - Power supply 230Vac/1Ph/50Hz.  
(1) (2) (3) (4) (5): Nominal technical data, refer to the nominal air flow (3) Vmax=10V, ESP=0, dry coil → For the performances (1) (2) in the operating air flow ref. 8+9 or the SW.  
(1) Cooling: Air temp: 20°C d.b., 19°C w.b. - Entering/leaving water temp: 7/12°C - Nominal air flow (3). For the operating air flows (ex. at the different Speed, Signals, ESP) see (8)+(9); ref. entering water temp. 7°C and nominal water flow (4). Recommended use of the SW.  
(2) Heating: Air temp.: 20°C - Entering/leaving water temp. 70/60°C - Nominal air flow (3). For the operating air flows (ex. at the different Speed, Signals, ESP) see (8)+(9); ref. entering water temp. 70°C and nominal water flow (4). Recommended use of the SW.  
(3) (2) (9) Cooling and Heating capacities: Data calculated by SW and measurements made in climatic room ref. UNI 7940 part 1°-2°, UNI-EN 1397/2001 standards.  
(3) (8) Air flow and static pressure: Nominal data measured with casing ref. AMCA210-74 fig.12 standards and plenum + diaphragm ref. CNR-UNI10023 standards.  
(6) Sound Levels: Free field sound pressure, 2 m distance. Data calculated based on sound power measured in reverberation room ref. ISO 3741 - ISO 3742 standards.  
(7) Electrical data: Data measured with Wattmeter Jokogawa WT10 (Max value, nominal of motor label = reference value for the electrical system design). For the operating electrical power absorption, energy efficiency class, etc. see paragraph "Tab UE-2016-2281 Regulation".

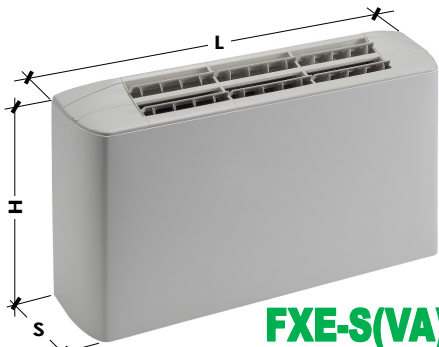

**FXE-S(VA)**  
Super Silenzioso

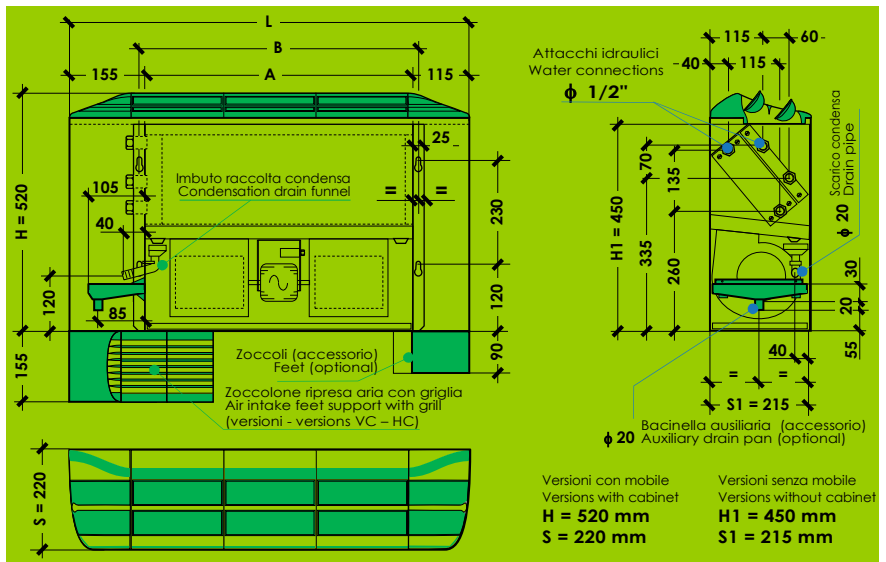

Versioni con mobile  
Versions with cabinet  
H = 520 mm  
S = 220 mm

Versioni senza mobile  
Versions without cabinet  
H1 = 450 mm  
S1 = 215 mm

Taglia - Size		DF-XE-S	131S	231S	331S	431S	531S	631S	731S	831S	931S	1031S	1131S	1231S	
Potenz. Frigorifera	Totale - Total (1)	W	1.390	1.850	2.310	2.730	3.490	3.920	5.090	5.920	6.730	8.060	8.610	9.620	
Cooling capacity	Sensibile - Sensible (1)	W	1.180	1.490	1.870	2.050	2.640	2.950	3.940	4.380	4.980	5.810	6.740	7.390	
Potenzialità Termica - Heating capacity (2)		W	1.800	1.880	2.960	3.120	4.180	4.330	5.920	6.120	7.270	7.380	10.080	10.200	
Portata aria nominale - Nominal Air flow (3)		m <sup>3</sup> /h	325	350	430	465	595	630	875	920	1.065	1.090	1.600	1.630	
Portata acqua	Raffred. - Cooling	l/h	239	318	397	470	600	674	875	1.018	1.158	1.386	1.481	1.655	
	Riscald. - Heating	l/h	155	162	255	268	359	372	509	526	625	635	867	877	
Perdite di carico acqua	Raffred. - Cooling	kPa	11,2	14,0	15,4	17,0	19,6	20,5	20,8	23,0	22,9	23,3	24,9	26,9	
	Riscald. - Heating	kPa	6,7	7,2	10,1	11,2	19,4	20,8	36,4	38,9	31,2	32,2	40,0	41,0	
Livelli sonori - Sound levels (6)	Min-Med-Max	dB(A)	<10-17-30	<10-18-31	<10-17-34	10-22-36	11-21-30	12-22-31	11-26-35	12-28-36	<10-27-39	10-28-40	11-30-40	12-31-41	
Ref. FAN-DECK			SWP/STD.1/7, SWD/STD.1/7		SWP/STD.1/7, SWD/STD.1/7		SWP/STD.1/7, SWD/STD.1/7		SWP/STD.1/8, SWD/STD.1/8		SWP/STD.1/9, SWD/STD.1/9		SWP/FX.1/10, SWD/FXD2.1/10		
Motori/Ventilatori - Motors/Fans	No./No.		1/1		1/1		1/2		1/2		1/2		1/3		
Assorb. elettrico nominale (Targa)	MAX(7)	W	55W		65W		85W		90W		90W		180W		
Nominal current input (Label)	MAX(7)	A	0,35A		0,45A		0,55A		0,55A		0,55A		1,40A		
<b>Alimentazione elettrica - Power supply</b>			<b>230Vac-1Ph-50/60Hz (Signal 0...10Vdc)</b>												
Batteria caldo/freddo	Contenuto acqua - Water volume (l)		0,69	0,70	0,99	1,01	1,30	1,31	1,60	1,62	1,91	1,92	2,21	2,23	
	[Ranghij], DN(*) - [Rows], DN(*)		[3R], 1/2" F		[3R], 1/2" F		[3R], 1/2" F		[3R], 1/2" F		[3R], 1/2" F		[3R], 1/2" F		
Batteria caldo	Contenuto acqua - Water volume (l)		0,23		0,33		0,43		0,54		0,64		0,74		
	[Ranghij], DN(*) - [Rows], DN(*)		[1R], 1/2" F		[1R], 1/2" F		[1R], 1/2" F		[1R], 1/2" F		[1R], 1/2" F		[1R], 1/2" F		
Scarico condensa - Drain pipe	φ (mm)		20		20		20		20		20		20		
	L	mm	670		870		1.070		1.270		1.470		1.670		
Dimensioni principali	H	mm	470		470		470		470		470		470		
	S	mm	220		220		220		220		220		220		
	A	mm	400		600		800		1.000		1.200		1.400		
	B	mm	425		625		825		1.025		1.225		1.425		
Limite funzionam. inferiore	LFI	ESP = 0 Pa	10V	1,00	1,00	1,00	1,00	1,00	1,00	1,00	1,00	1,00	1,00	1,00	1,00
			Med	0,66	0,66	0,66	0,66	0,70	0,70	0,66	0,66	0,63	0,63	0,64	0,64
			1V	0,33	0,33	0,32	0,32	0,40	0,40	0,32	0,32	0,26	0,26	0,28	0,28
			10V	0,92	0,92	0,92	0,92	0,90	0,90	0,90	0,90	0,92	0,92	0,95	0,95
(8) RIDUZIONE PORTATA ARIA	15 Pa	Med	10V	0,61	0,61	0,61	0,61	0,63	0,63	0,59	0,59	0,58	0,58	0,61	0,61
			1V	0,30	0,30	0,29	0,29	0,36	0,36	0,29	0,29	0,24	0,24	0,26	0,26
AIR FLOW REDUCTION	30 Pa	Med	10V	0,82	0,82	0,83	0,83	0,79	0,79	0,79	0,79	0,82	0,82	0,88	0,88
			1V	0,27	0,27	0,26	0,26	0,32	0,32	0,26	0,26	0,21	0,21	0,24	0,25
Coefficients defining the "Air flow / Static pressure" Diagr.(at 3 speed Max-Med-Min)	45 Pa	Med	10V	0,67	0,67	0,71	0,71	0,65	0,65	0,67	0,67	0,69	0,69	0,81	0,81
			1V	0,22	0,22	0,22	0,22	0,26	0,26	0,21	0,21	0,18	0,18	0,22	0,22
(10V-Med-1V = Max-Med-Min)	ESP (Pa)	Med	10V	72 Pa	72 Pa	80 Pa	80 Pa	85 Pa	85 Pa	86 Pa	86 Pa	83 Pa	83 Pa	107 Pa	107 Pa
			1V	x 0,20	x 0,20	x 0,20	x 0,20	x 0,20	x 0,20	x 0,20	x 0,20	x 0,20	x 0,20	x 0,20	x 0,20
LFS	ESP (Pa)	Med	10V	68 Pa	68 Pa	77 Pa	77 Pa	79 Pa	79 Pa	79 Pa	79 Pa	76 Pa	76 Pa	100 Pa	100 Pa
			1V	x 0,19	x 0,19	x 0,20	x 0,20	x 0,19	x 0,19	x 0,19	x 0,19	x 0,19	x 0,19	x 0,19	x 0,19
Limite funzionam. superiore	ESP (Pa)	1V	10V	55 Pa	55 Pa	61 Pa	61 Pa	66 Pa	66 Pa	60 Pa	60 Pa	52 Pa	52 Pa	73 Pa	73 Pa
			1V	x 0,17	x 0,17	x 0,17	x 0,17	x 0,17	x 0,17	x 0,17	x 0,17	0,16	0,16	x 0,17	x 0,17

(9) RIDUZIONE POTENZIALITÀ FRIGORIFERA/TERMICA (in funzione della riduzione portata aria)  
COOLING/HEATING CAPACITY REDUCTION (depending on air flow reduction)

Portata aria - Air flow	1.00	0.95	0.90	0.85	0.80	0.75	0.70	0.65	0.60	0.55	0.50	0.45	0.40	0.35	0.30	0.25	0.20	0.15
Potenzial. Frigorifera	1,00	0,97	0,95	0,92	0,89	0,87	0,84	0,81	0,77	0,74	0,71	0,67	0,63	0,59	0,55	0,50	0,45	0,39
Cooling capacity	1,00	0,97	0,93	0,90	0,86	0,83	0,79	0,76	0,72	0,68	0,64	0,60	0,55	0,51	0,46	0,41	0,35	0,29
Potenzialità termica - Heating capacity	1,00	0,97	0,94	0,91	0,87	0,84	0,81	0,77	0,74	0,70	0,66	0,62	0,58	0,53	0,49	0,44	0,38	0,32

DN(\*) = Diametro nominale, F = Attacchi idraulici batteria Gas femmina

DN(\*) = Nominal diameter, F = Female gas water coil connections  
Technical data refer to the following conditions: Standard unit - Atmospheric pressure 1013 mbar - Power supply 230Vac/1Ph/50Hz.  
(1) (2) (3) (4) (5): Dati tecnici nominali, portata aria nom. (3) @ Vmax=10V, ESP=0, batteria uscita → Per le portate aria di funzionamento riferite a B+H o al SW.  
(1) (2) (3) (4) (5): Nominal technical data, refer to the nominal air flow (3) @ Vmax=10V, ESP=0, dry coil → In the operating air flow ref. B+H or the SW.  
(1) (2) (3) (4) (5): Ref. entering water temp., 70°C w.i. - Entering/leaving water temp., 71/12°C - Nominal air flow (3). For the operating air flows (ref. at the different Speed, Signals, ESP) see (8) (9); ref. entering water temp., 7°C and nominal water flow (4). Recommended use of the SW.  
(2) Heating: Air temp.: 20°C - Entering/leaving water temp., 70/60°C - Nominal air flow (3). For the operating air flows (ref. at the different Speed, Signals, ESP) see (8) (9); ref. entering water temp., 70°C and nominal water flow (4). Recommended use of the SW.  
(3) (8) (9) Cooling and Heating capacities: Data calculated by SW and measurements made in calorimetric room ref. UNI 7940 part 1°-2°, UNI-EN 1397/2001.  
(3) (8) Portata aria e Press. statica: Valori nominali rilevati con cassone di norme AMCA210-74 fig.12 e condotto a diametro di norme CNR-UNI10023.  
(4) Livelli sonori: Valori sonori in campo libero, distanza 2 m. Valori calcolati da potenza sonora rilevata in camera invertebrante ref. norme ISO 3741 - ISO 3742.  
(5) Dati elettrici: Valori rilevati con Wattmetro Jolegova WT10 (Valore max. nominale, di tarso motore = valore di riferimento per progettazione impianto elettrico). Per gli assorbimenti elettrici in funzionamento, classi efficienza energetica, ecc. vedi paragrafo "Tab Regolamento UE-2016-2281".  
For the operating electrical power absorption, energy efficiency class, etc. see paragraph "Tab UE-2016-2281 Regulation".

DN(\*) = Diametro nominale, F = Attacchi idraulici batteria Gas femmina

DN(\*) = Nominal diameter, F = Female gas water coil connections  
Technical data refer to the following conditions: Standard unit - Atmospheric pressure 1013 mbar - Power supply 230Vac/1Ph/50Hz.  
(1) (2) (3) (4) (5): Dati tecnici nominali, portata aria nom. (3) @ Vmax=10V, ESP=0, batteria uscita → Per le portate aria di funzionamento riferite a B+H o al SW.  
(1) (2) (3) (4) (5): Nominal technical data, refer to the nominal air flow (3) @ Vmax=10V, ESP=0, dry coil → In the operating air flow ref. B+H or the SW.  
(1) (2) (3) (4) (5): Ref. entering water temp., 70°C w.i. - Entering/leaving water temp., 71/12°C - Nominal air flow (3). For the operating air flows (ref. at the different Speed, Signals, ESP) see (8) (9); ref. entering water temp., 7°C and nominal water flow (4). Recommended use of the SW.  
(2) Heating: Air temp.: 20°C - Entering/leaving water temp., 70/60°C - Nominal air flow (3). For the operating air flows (ref. at the different Speed, Signals, ESP) see (8) (9); ref. entering water temp., 70°C and nominal water flow (4). Recommended use of the SW.  
(3) (8) (9) Cooling and Heating capacities: Data calculated by SW and measurements made in calorimetric room ref. UNI 7940 part 1°-2°, UNI-EN 1397/2001.  
(3) (8) Air flow and Static pressure: Nominal data measured with casing ref. AMCA210-74 fig.12 standards and plenum + diaphragm ref. CNR-UNI10023 standards.  
(4) Sound Levels: Free field sound pressure, 2 m distance. Data calculated based on sound power measured in reverberant room ref. ISO 3741 - ISO 3742 standards.  
(5) Electrical data: Data measured with Wattmeter Jolegova WT10 (Max value, nominal of motor label = reference value for the electrical system design).  
For the operating electrical power absorption, energy efficiency class, etc. see paragraph "Tab UE-2016-2281 Regulation".

## Versione verticale a parete (mobile base) Vertical wall version (basic cabinet)

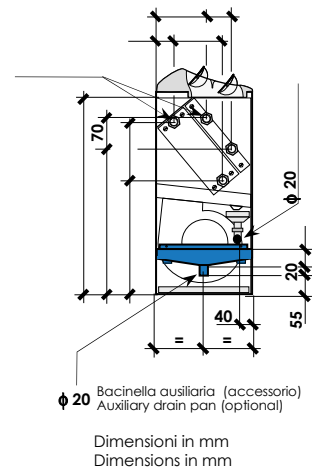
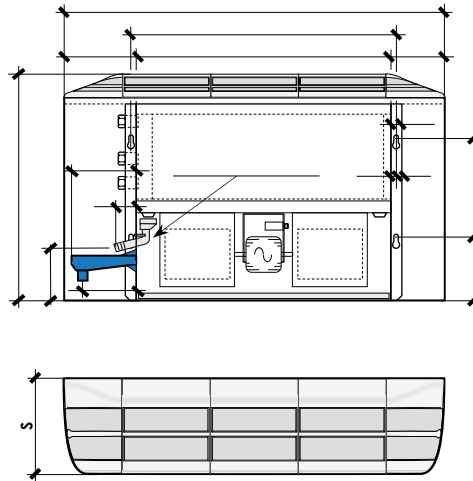
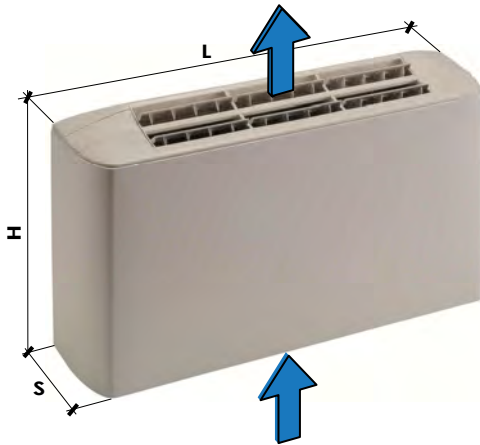

Taglia - Size		DF-X, FXE, ...	100	200	300	400	500	600	700	800	900	1000	1100	1200	
Dimensioni principali Main dimensions	L	mm	670	670	870	870	1.070	1.070	1.270	1.270	1.470	1.470	1.670	1.670	
	H	mm	520	520	520	520	520	520	520	520	520	520	520	520	
	S	mm	220	220	220	220	220	220	220	220	220	220	220	220	
	A	mm	400	400	600	600	800	800	1.000	1.000	1.200	1.200	1.400	1.400	
	B	mm	425	425	625	625	825	825	1.025	1.025	1.225	1.225	1.425	1.425	
N° Motori			1	1	1	1	1	1	1	1	1	1	1	1	
N° Ventilatori			1	1	1	1	2	2	2	2	2	2	3	3	
Batteria caldo/freddo Heating/cooling coil	Contenuto acqua Water volume (l)		0,69	0,70	0,99	1,01	1,30	1,31	1,60	1,62	1,91	1,92	2,21	2,23	
	Ranghi - Rows DN(*)		3R 1/2" F	3R 1/2" F	3R 1/2" F	3R 1/2" F	3R 1/2" F	3R 1/2" F	3R 1/2" F	3R 1/2" F	3R 1/2" F	3R 1/2" F	3R 1/2" F	3R 1/2" F	3R 1/2" F
Batteria caldo Heating coil	Contenuto acqua Water volume (l)		0,23	0,23	0,33	0,33	0,43	0,43	0,54	0,54	0,64	0,64	0,74	0,74	
	Ranghi - Rows DN(*)		1R 1/2" F	1R 1/2" F	1R 1/2" F	1R 1/2" F	1R 1/2" F	1R 1/2" F	1R 1/2" F	1R 1/2" F	1R 1/2" F	1R 1/2" F	1R 1/2" F	1R 1/2" F	1R 1/2" F
Scarico condensa - Drain pipe			$\phi$ (mm)	20	20	20	20	20	20	20	20	20	20	20	
FX	Ref. FAN-DECK		C2, A40.6V, [P2-3-5],[N1-2-4]		C3,15, A40.6V, [P2-3-5],[N1-2-4]		C3,15, A80.6V, [P2-3-5],[N1-2-4]		C5, A80.6V, [P2-3-5],[N1-2-4]		C3,15, A80.6V, [P2-3-5],[N1-2-4]		C3,15, 5V, [P2-3-4],[N1-3-4]		
	Peso netto	2 Tubi/Pipe	Kg	13,5	14,0	16,4	17,2	22,5	23,5	26,0	27,5	30,0	31,5	32,9	36,4
	Net weight	4 Tubi/Pipe	Kg	14,4	14,9	17,4	18,2	23,6	24,6	27,2	28,7	31,3	32,8	34,3	37,8
FX-P	Ref. FAN-DECK		C3,15, A40.6V, [P2-3-5],[N1-2-4]		C3,15, A80.6V, [P2-3-5],[N1-2-4]		C2, A80.6V, [P2-3-5],[N1-2-4]		C4, A80.6V, [P2-3-5],[N1-2-4]		C4, 6V, [P2-3-4],[N1-3-5]		C4, 5V, [P2-3-4],[N1-3-4]		
	Peso netto	2 Tubi/Pipe	Kg	14,1	14,6	17,2	18,0	23,0	24,0	26,9	28,4	31,1	32,6	34,0	37,5
	Net weight	4 Tubi/Pipe	Kg	15,0	15,5	18,2	19,0	24,1	25,1	28,1	29,6	32,4	33,9	35,4	38,9
FX-S	Ref. FAN-DECK		C1,5, A40.6V, [P4-5-6],[N4-5-6]		C2,5, A40.6V, [P4-5-6],[N4-5-6]		C2,5, A80.6V, [P4-5-6],[N4-5-6]		C4, A80.6V, [P4-5-6],[N4-5-6]		C2,5, A80.6V, [P4-5-6],[N4-5-6]		C4, V3-A240, [P4-5-6],[N4-5-6]		
	Peso netto	2 Tubi/Pipe	Kg	14,2	14,7	17,1	17,9	23,2	24,2	26,7	28,2	30,7	32,2	33,6	37,1
	Net weight	4 Tubi/Pipe	Kg	15,1	15,6	18,1	18,9	24,3	25,3	27,9	29,4	32,0	33,5	35,0	38,5
FXE	Ref. FAN-DECK		SWP/STD.1/10, SWN/STD.1/10		SWP/STD.1/10, SWN/STD.1/10		SWP/STD.1/10, SWN/PotD.1/10		SWP/STD.1/10, SWN/PotH.1/10		SWP/STD.1/10, SWN/PotH.1/10		SWP/RX.1/10, SWD/RXD.1/10		
	Peso netto	2 Tubi/Pipe	Kg	13,1	13,6	16,5	17,3	22,9	23,9	25,9	27,4	29,1	30,6	32,7	36,2
	Net weight	4 Tubi/Pipe	Kg	14,0	14,5	17,5	18,3	24,0	25,0	27,1	28,6	30,4	31,9	34,1	37,6
FXE-P	Ref. FAN-DECK		SWP/STD.1/10, SWD/STD.1/10		SWP/STD.1/10, SWD/STD.1/10		SWP/Pot.1/10, SWD/Pot.1/10		SWP/Pot.1/10, SWD/Pot.1/10		SWP/RX.1/10, SWD/RX.1/10		SWP/RX.1/10, SWD/RX.1/10		
	Peso netto	2 Tubi/Pipe	Kg	13,4	13,9	16,8	17,6	23,2	24,2	26,2	27,7	29,4	30,9	33,0	36,5
	Net weight	4 Tubi/Pipe	Kg	14,3	14,8	17,8	18,6	24,3	25,3	27,4	28,9	30,7	32,2	34,4	37,9
FXE-S	Ref. FAN-DECK		SWP/STD.1/7, SWD/STD.1/7		SWP/STD.1/7, SWD/STD.1/7		SWP/STD.1/7, SWD/STD.1/7		SWP/STD.1/8, SWD/STD.1/8		SWP/STD.1/9, SWD/STD.1/9		SWP/RX.1/10, SWD/RXD.2/10		
	Peso netto	2 Tubi/Pipe	Kg	14,1	14,6	17,5	18,3	23,9	24,9	26,9	28,4	30,1	31,6	33,7	37,2
	Net weight	4 Tubi/Pipe	Kg	15,0	15,5	18,5	19,3	25,0	26,0	28,1	29,6	31,4	32,9	35,1	38,6
FXE+	Ref. FAN-DECK		SWP/STD.1/10, SWN/STD.1/10		SWP/STD.1/10, SWN/STD.1/10		Non disponibile		Non disponibile		Non disponibile		Non disponibile		
	Peso netto	2 Tubi/Pipe	Kg	13,9	14,4	17,3	18,1	Not available		Not available		Not available			
	Net weight	4 Tubi/Pipe	Kg	14,8	15,3	18,3	19,1	Not available		Not available		Not available			
DN(*) = Diametro nominale, F = Attacchi idraulici batteria Gas femmina			DN(*) = Nominal diameter, F = Female gas water coil connections												
▪ Peso netto= solo unità, escluso imballo			▪ Net weight= unit only, excluding packaging												

## Versione verticale a pavimento (mobile con griglia aspirazione aria frontale) Vertical floor version (cabinet with front air intake grill)

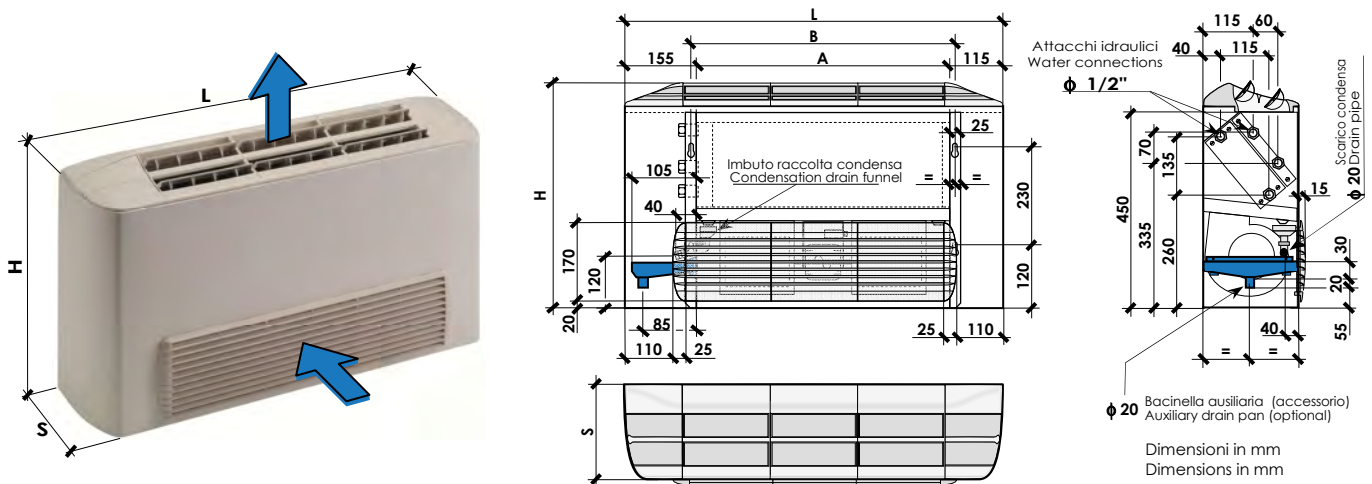

Taglia - Size		DF-X, FXE, ...	100	200	300	400	500	600	700	800	900	1000	1100	1200
Dimensioni principali Main dimensions	L	mm	670	670	870	870	1.070	1.070	1.270	1.270	1.470	1.470	1.670	1.670
	H	mm	520	520	520	520	520	520	520	520	520	520	520	520
	S	mm	220	220	220	220	220	220	220	220	220	220	220	220
	A	mm	400	400	600	600	800	800	1.000	1.000	1.200	1.200	1.400	1.400
	B	mm	425	425	625	625	825	825	1.025	1.025	1.225	1.225	1.425	1.425
N° Motori			1	1	1	1	1	1	1	1	1	1	1	1
N° Ventilatori			1	1	1	1	2	2	2	2	2	2	3	3
Batteria caldo/freddo Heating/cooling coil	Contenuto acqua Water volume (l)		0,69	0,70	0,99	1,01	1,30	1,31	1,60	1,62	1,91	1,92	2,21	2,23
	Ranghi - Rows DN(*)		3R 1/2" F	3R 1/2" F	3R 1/2" F	3R 1/2" F	3R 1/2" F	3R 1/2" F	3R 1/2" F	3R 1/2" F	3R 1/2" F	3R 1/2" F	3R 1/2" F	3R 1/2" F
Batteria caldo Heating coil	Contenuto acqua Water volume (l)		0,23	0,23	0,33	0,33	0,43	0,43	0,54	0,54	0,64	0,64	0,74	0,74
	Ranghi - Rows DN(*)		1R 1/2" F	1R 1/2" F	1R 1/2" F	1R 1/2" F	1R 1/2" F	1R 1/2" F	1R 1/2" F	1R 1/2" F	1R 1/2" F	1R 1/2" F	1R 1/2" F	1R 1/2" F
Scarico condensa - Drain pipe		φ(mm)	20	20	20	20	20	20	20	20	20	20	20	20
FX	Ref. FAN-DECK		C2, A40.6V, [P2-3-5],[N1-2-4]	C3,15, A40.6V, [P2-3-5],[N1-2-4]	C3,15, A40.6V, [P2-3-5],[N1-2-4]	C3,15, A80.6V, [P2-3-5],[N1-2-4]	C5, A80.6V, [P2-3-5],[N1-2-4]	C5, A80.6V, [P2-3-5],[N1-2-4]	C3,15, A80.6V, [P2-3-5],[N1-2-4]	C3,15, 5V, [P2-3-4],[ND,1-3-4]				
	Peso netto 2 Tubi/Pipe	Kg	13,8	14,3	16,9	17,7	23,2	24,2	26,9	28,4	31,1	32,6	34,2	37,7
	Net weight 4 Tubi/Pipe	Kg	14,7	15,2	17,9	18,7	24,3	25,3	28,1	29,6	32,4	33,9	35,6	39,1
FX-P	Ref. FAN-DECK		C3,15, A40.6V, [P2-3-5],[N1-2-4]	C3,15, A80.6V, [P2-3-5],[N1-2-4]	C2, A80.6V, [P2-3-5],[N1-2-4]	C4, A80.6V, [P2-3-5],[N1-2-4]	C4, 6V, [P2-3-4],[N1-3-5]	C4, 5V, [P2-3-4],[N1-3-4]						
	Peso netto 2 Tubi/Pipe	Kg	14,4	14,9	17,7	18,5	23,7	24,7	27,8	29,3	32,2	33,7	35,3	38,8
	Net weight 4 Tubi/Pipe	Kg	15,3	15,8	18,7	19,5	24,8	25,8	29,0	30,5	33,5	35,0	36,7	40,2
FX-S	Ref. FAN-DECK		C1,5, A40.6V, [P4-5-6],[N4-5-6]	C2,5, A40.6V, [P4-5-6],[N4-5-6]	C2,5, A80.6V, [P4-5-6],[N4-5-6]	C4, A80.6V, [P4-5-6],[N4-5-6]	C2,5, A80.6V, [P4-5-6],[N4-5-6]	C4, V3-A240, [P4-5-6],[N4-5-6]						
	Peso netto 2 Tubi/Pipe	Kg	14,5	15,0	17,6	18,4	23,9	24,9	27,6	29,1	31,8	33,3	34,9	38,4
	Net weight 4 Tubi/Pipe	Kg	15,4	15,9	18,6	19,4	25,0	26,0	28,8	30,3	33,1	34,6	36,3	39,8
FXE	Ref. FAN-DECK		SWP/STD.1/10, SWN/STD.1/10	SWP/STD.1/10, SWN/STD.1/10	SWP/STD.1/10, SWN/PotID.1/10	SWP/STD.1/10, SWN/PotID.1/10	SWP/STD.1/10, SWN/PotID.1/10	SWP/STD.1/10, SWN/PotID.1/10	SWP/STD.1/10, SWN/PotID.1/10	SWP/RX.1/10, SWD/RXD.1/10	SWP/RX.1/10, SWD/RXD.1/10			
	Peso netto 2 Tubi/Pipe	Kg	13,4	13,9	17,0	17,8	23,6	24,6	26,8	28,3	30,2	31,7	34,0	37,5
	Net weight 4 Tubi/Pipe	Kg	14,3	14,8	18,0	18,8	24,7	25,7	28,0	29,5	31,5	33,0	35,4	38,9
FXE-P	Ref. FAN-DECK		SWP/STD.1/10, SWD/STD.1/10	SWP/STD.1/10, SWD/STD.1/10	SWP/PotI.1/10, SWD/PotI.1/10	SWP/PotI.1/10, SWD/PotI.1/10	SWP/PotI.1/10, SWD/PotI.1/10	SWP/RX.1/10, SWD/RX.1/10	SWP/RX.1/10, SWD/RX.1/10					
	Peso netto 2 Tubi/Pipe	Kg	13,7	14,2	17,3	18,1	23,9	24,9	27,1	28,6	30,5	32,0	34,3	37,8
	Net weight 4 Tubi/Pipe	Kg	14,6	15,1	18,3	19,1	25,0	26,0	28,3	29,8	31,8	33,3	35,7	39,2
FXE-S	Ref. FAN-DECK		SWP/STD.1/7, SWD/STD.1/7	SWP/STD.1/7, SWD/STD.1/7	SWP/STD.1/7, SWD/STD.1/7	SWP/STD.1/8, SWD/STD.1/8	SWP/STD.1/9, SWD/STD.1/9	SWP/RX.1/10, SWD/RXD.1/10						
	Peso netto 2 Tubi/Pipe	Kg	14,4	14,9	18,0	18,8	24,6	25,6	27,8	29,3	31,2	32,7	35,0	38,5
	Net weight 4 Tubi/Pipe	Kg	15,3	15,8	19,0	19,8	25,7	26,7	29,0	30,5	32,5	34,0	36,4	39,9
FXE+	Ref. FAN-DECK		SWP/STD.1/10, SWN/STD.1/10	SWP/STD.1/10, SWN/STD.1/10	Non disponibile	Non disponibile	Non disponibile	Non disponibile						
	Peso netto 2 Tubi/Pipe	Kg	14,2	14,7	17,8	18,6	Non disponibile	Non disponibile						
	Net weight 4 Tubi/Pipe	Kg	15,1	15,6	18,8	19,6	Non disponibile	Non disponibile						

DN(\*) = Diametro nominale, F = Attacchi idraulici batteria Gas femmina

DN(\*) = Nominal diameter, F = Female gas water coil connections

▪ Peso netto= solo unità, escluso imballo

▪ Net weight= unit only, excluding packaging

## Versione verticale a pavimento (mobile con zoccolone+griglia aspirazione aria) Vertical floor version (cabinet with air intake feet support+grill)

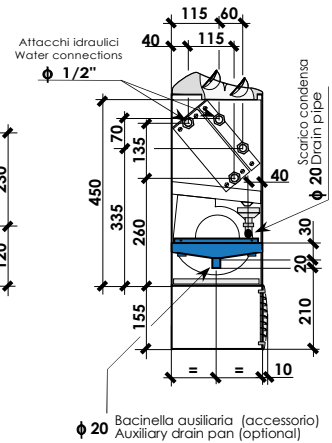
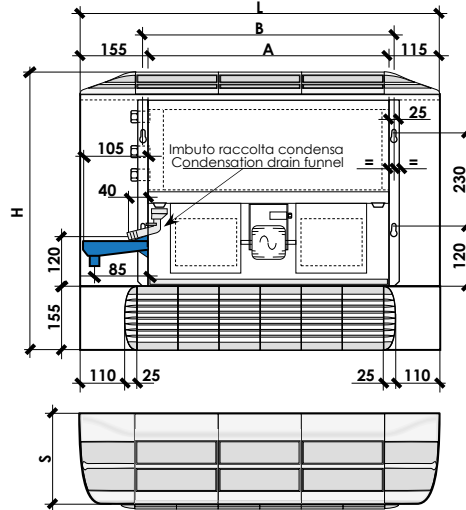
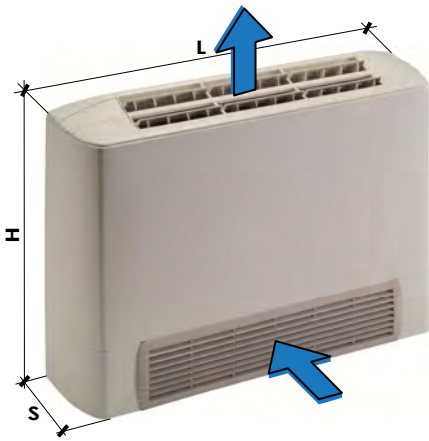

Dimensioni in mm  
Dimensions in mm

Taglia - Size		DF-X, FXE, ...	100	200	300	400	500	600	700	800	900	1000	1100	1200
Dimensioni principali Main dimensions	L	mm	670	670	870	870	1.070	1.070	1.270	1.270	1.470	1.470	1.670	1.670
	H	mm	675	675	675	675	675	675	675	675	675	675	675	675
	S	mm	220	220	220	220	220	220	220	220	220	220	220	220
	A	mm	400	400	600	600	800	800	1.000	1.000	1.200	1.200	1.400	1.400
	B	mm	425	425	625	625	825	825	1.025	1.025	1.225	1.225	1.425	1.425
N° Motori			1	1	1	1	1	1	1	1	1	1	1	1
N° Ventilatori			1	1	1	1	2	2	2	2	2	2	3	3
Batteria caldo/freddo Heating/cooling coil	Contenuto acqua Water volume (l)		0,69	0,70	0,99	1,01	1,30	1,31	1,60	1,62	1,91	1,92	2,21	2,23
	Ranghi - Rows DN(*)		3R 1/2" F	3R 1/2" F	3R 1/2" F	3R 1/2" F	3R 1/2" F	3R 1/2" F	3R 1/2" F	3R 1/2" F	3R 1/2" F	3R 1/2" F	3R 1/2" F	3R 1/2" F
Batteria caldo Heating coil	Contenuto acqua Water volume (l)		0,23	0,23	0,33	0,33	0,43	0,43	0,54	0,54	0,64	0,64	0,74	0,74
	Ranghi - Rows DN(*)		1R 1/2" F	1R 1/2" F	1R 1/2" F	1R 1/2" F	1R 1/2" F	1R 1/2" F	1R 1/2" F	1R 1/2" F	1R 1/2" F	1R 1/2" F	1R 1/2" F	1R 1/2" F
Scarico condensa - Drain pipe		φ(mm)	20	20	20	20	20	20	20	20	20	20	20	20
FX	Ref. FAN-DECK		C2, A40.6V, [P2-3-5],[N1-2-4]		C3,15, A40.6V, [P2-3-5],[N1-2-4]		C3,15, A80.6V, [P2-3-5],[N1-2-4]		C5, A80.6V, [P2-3-5],[N1-2-4]		C3,15, A80.6V, [P2-3-5],[N1-2-4]		C3,15, 5V, [P2-3-4],[ND,1-3-4]	
	Peso netto 2 Tubi/Pipe	Kg	15,0	15,5	18,2	19,0	24,6	25,6	28,4	29,9	32,7	34,2	35,9	39,4
	Net weight 4 Tubi/Pipe	Kg	15,9	16,4	19,2	20,0	25,7	26,7	29,6	31,1	34,0	35,5	37,3	40,8
FX-P	Ref. FAN-DECK		C3,15, A40.6V, [P2-3-5],[N1-2-4]		C3,15, A80.6V, [P2-3-5],[N1-2-4]		C2, A80.6V, [P2-3-5],[N1-2-4]		C4, A80.6V, [P2-3-5],[N1-2-4]		C4, 6V, [P2-3-4],[N1-3-5]		C4, 5V, [P2-3-4],[N1-3-4]	
	Peso netto 2 Tubi/Pipe	Kg	15,6	16,1	19,0	19,8	25,1	26,1	29,3	30,8	33,8	35,3	37,0	40,5
	Net weight 4 Tubi/Pipe	Kg	16,5	17,0	20,0	20,8	26,2	27,2	30,5	32,0	35,1	36,6	38,4	41,9
FX-S	Ref. FAN-DECK		C1,5, A40.6V, [P4-5-6],[N4-5-6]		C2,5, A40.6V, [P4-5-6],[N4-5-6]		C2,5, A80.6V, [P4-5-6],[N4-5-6]		C4, A80.6V, [P4-5-6],[N4-5-6]		C2,5, A80.6V, [P4-5-6],[N4-5-6]		C4, V3-A240, [P4-5-6],[N4-5-6]	
	Peso netto 2 Tubi/Pipe	Kg	15,7	16,2	18,9	19,7	25,3	26,3	29,1	30,6	33,4	34,9	36,6	40,1
	Net weight 4 Tubi/Pipe	Kg	16,6	17,1	19,9	20,7	26,4	26,4	30,3	31,8	34,7	36,2	38,0	41,5
FXE	Ref. FAN-DECK		SWP/STD.1/10, SWN/STD.1/10		SWP/STD.1/10, SWN/STD.1/10		SWP/STD.1/10, SWN/Pot1.D/1/10		SWP/STD.1/10, SWN/Pot1.D/1/10		SWP/STD.1/10, SWN/Pot1.1/10		SWP/RX.1/10, SWD/RXD.1/1/10	
	Peso netto 2 Tubi/Pipe	Kg	14,6	15,1	18,3	19,1	25,0	26,0	28,3	29,8	31,8	33,3	35,7	39,2
	Net weight 4 Tubi/Pipe	Kg	15,5	16,0	19,3	20,1	26,1	27,1	29,5	31,0	33,1	34,6	37,1	40,6
FXE-P	Ref. FAN-DECK		SWP/STD.1/10, SWD/STD.1/10		SWP/STD.1/10, SWD/STD.1/10		SWP/Pot1.1/10, SWD/Pot1.1/10		SWP/Pot1.1/10, SWD/Pot1.1/10		SWP/RX.1/10, SWD/RX.1/10		SWP/RX.1/10, SWD/RX.1/10	
	Peso netto 2 Tubi/Pipe	Kg	14,9	15,4	18,6	19,4	25,3	26,3	28,6	30,1	32,1	33,6	36,0	39,5
	Net weight 4 Tubi/Pipe	Kg	15,8	16,3	19,6	20,4	26,4	27,4	29,8	31,3	33,4	34,9	37,4	40,9
FXE-S	Ref. FAN-DECK		SWP/STD.1/7, SWD/STD.1/7		SWP/STD.1/7, SWD/STD.1/7		SWP/STD.1/7, SWD/STD.1/7		SWP/STD.1/8, SWD/STD.1/8		SWP/STD.1/9, SWD/STD.1/9		SWP/RX.1/10, SWD/RXD.2/1/10	
	Peso netto 2 Tubi/Pipe	Kg	15,6	16,1	19,3	20,1	26,0	27,0	29,3	30,8	32,8	34,3	36,7	40,2
	Net weight 4 Tubi/Pipe	Kg	16,5	17,0	20,3	21,1	27,1	28,1	30,5	32,0	34,1	35,6	38,1	41,6
FXE+	Ref. FAN-DECK		SWP/STD.1/10, SWN/STD.1/10		SWP/STD.1/10, SWN/STD.1/10		Non disponibile		Non disponibile		Non disponibile		Non disponibile	
	Peso netto 2 Tubi/Pipe	Kg	15,4	15,9	19,1	19,9	Not available		Not available		Not available		Not available	
	Net weight 4 Tubi/Pipe	Kg	16,3	16,8	20,1	20,9	Not available		Not available		Not available		Not available	
<b>DN(*) = Diametro nominale, F = Attacchi idraulici batteria Gas femmina</b>														
<b>DN(*) = Nominal diameter, F = Female gas water coil connections</b>														
▪ Peso netto= solo unità, escluso imballo														
▪ Net weight= unit only, excluding packaging														

## Versione orizzontale a soffitto (mobile base) Horizontal ceiling version (basic cabinet)

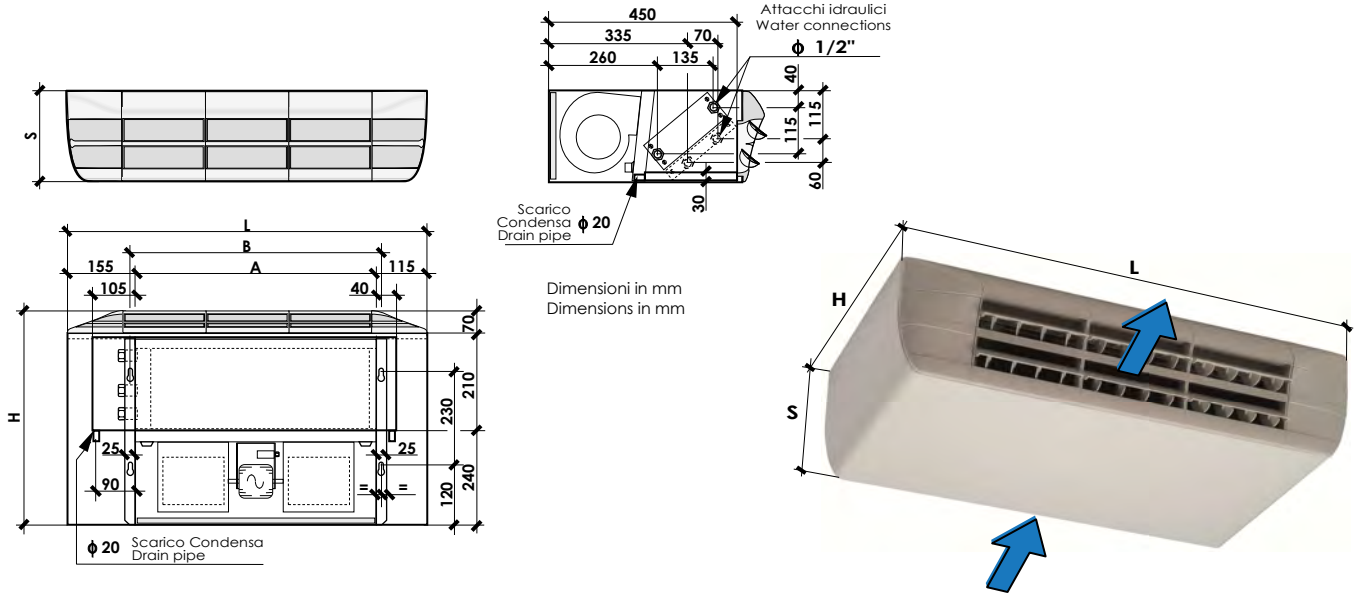

Taglia - Size		DF-X, FXE, ...	100	200	300	400	500	600	700	800	900	1000	1100	1200	
Dimensioni principali Main dimensions	L	mm	670	670	870	870	1.070	1.070	1.270	1.270	1.470	1.470	1.670	1.670	
	H	mm	520	520	520	520	520	520	520	520	520	520	520	520	
	S	mm	220	220	220	220	220	220	220	220	220	220	220	220	
	A	mm	400	400	600	600	800	800	1.000	1.000	1.200	1.200	1.400	1.400	
	B	mm	425	425	625	625	825	825	1.025	1.025	1.225	1.225	1.425	1.425	
N° Motori N° Ventilatori			1 1	1 1	1 1	1 1	1 2	1 2	1 2	1 2	1 2	1 2	1 3	1 3	
Batteria caldo/freddo Heating/cooling coil	Contenuto acqua Water volume (l)		0,69	0,70	0,99	1,01	1,30	1,31	1,60	1,62	1,91	1,92	2,21	2,23	
	Ranghi - Rows DN(*)		3R 1/2" F	3R 1/2" F	3R 1/2" F	3R 1/2" F	3R 1/2" F	3R 1/2" F	3R 1/2" F	3R 1/2" F	3R 1/2" F	3R 1/2" F	3R 1/2" F	3R 1/2" F	
Batteria caldo Heating coil	Contenuto acqua Water volume (l)		0,23	0,23	0,33	0,33	0,43	0,43	0,54	0,54	0,64	0,64	0,74	0,74	
	Ranghi - Rows DN(*)		1R 1/2" F	1R 1/2" F	1R 1/2" F	1R 1/2" F	1R 1/2" F	1R 1/2" F	1R 1/2" F	1R 1/2" F	1R 1/2" F	1R 1/2" F	1R 1/2" F	1R 1/2" F	
Scarico condensa - Drain pipe			φ(mm)		20	20	20	20	20	20	20	20	20	20	
FX	Ref. FAN-DECK		C2, A40.6V, [P2-3-5],[N1-2-4]		C3.15, A40.6V, [P2-3-5],[N1-2-4]		C3.15, A80.6V, [P2-3-5],[N1-2-4]		C5, A80.6V, [P2-3-5],[N1-2-4]		C3.15, A80.6V, [P2-3-5],[N1-2-4]		C3.15, 5V, [P2-3-4],[ND,1-3-4]		
	Peso netto	2 Tubi/Pipe	Kg	14,7	15,2	18,0	18,8	24,5	25,5	28,4	29,9	32,8	34,3	36,1	39,6
	Net weight	4 Tubi/Pipe	Kg	15,6	16,1	19,0	19,8	25,6	26,6	29,6	31,1	34,1	35,6	37,5	41,0
FX-P	Ref. FAN-DECK		C3.15, A40.6V, [P2-3-5],[N1-2-4]		C3.15, A80.6V, [P2-3-5],[N1-2-4]		C2, A80.6V, [P2-3-5],[N1-2-4]		C4, A80.6V, [P2-3-5],[N1-2-4]		C4, 6V, [P2-3-4],[N1-3-5]		C4, 5V, [P2-3-4],[N1-3-4]		
	Peso netto	2 Tubi/Pipe	Kg	15,3	15,8	18,8	19,6	25,0	26,0	29,3	30,8	33,9	35,4	37,2	40,7
	Net weight	4 Tubi/Pipe	Kg	16,2	16,7	19,8	20,6	26,1	27,1	30,5	32,0	35,2	36,7	38,6	42,1
FX-S	Ref. FAN-DECK		C1.5, A40.6V, [P4-5-6],[N4-5-6]		C2.5, A40.6V, [P4-5-6],[N4-5-6]		C2.5, A80.6V, [P4-5-6],[N4-5-6]		C4, A80.6V, [P4-5-6],[N4-5-6]		C2.5, A80.6V, [P4-5-6],[N4-5-6]		C4, V3-A240, [P4-5-6],[N4-5-6]		
	Peso netto	2 Tubi/Pipe	Kg	15,4	15,9	18,7	19,5	25,2	26,2	29,1	30,6	33,5	35,0	36,8	40,3
	Net weight	4 Tubi/Pipe	Kg	16,3	16,8	19,7	20,5	26,3	27,3	30,3	31,8	34,8	36,3	38,2	41,7
FXE	Ref. FAN-DECK		SWP/STD.1/10, SWN/STD.1/10		SWP/STD.1/10, SWN/STD.1/10		SWP/STD.1/10, SWN/Pot1.D.1/10		SWP/STD.1/10, SWN/Pot1.D.1/10		SWP/STD.1/10, SWN/Pot1.1/10		SWP/FIX.1/10, SWD/FIXD.1/10		
	Peso netto	2 Tubi/Pipe	Kg	14,3	14,8	18,1	18,9	24,9	25,9	28,3	29,8	31,9	33,4	35,9	39,4
	Net weight	4 Tubi/Pipe	Kg	15,2	15,7	19,1	19,9	26,0	27,0	29,5	31,0	33,2	34,7	37,3	40,8
FXE-P	Ref. FAN-DECK		SWP/STD.1/10, SWD/STD.1/10		SWP/STD.1/10, SWD/STD.1/10		SWP/Pot1.1/10, SWD/Pot1.1/10		SWP/Pot1.1/10, SWD/Pot1.1/10		SWP/FIX.1/10, SWD/FIX.1/10		SWP/FIX.1/10, SWD/FIXD.1/10		
	Peso netto	2 Tubi/Pipe	Kg	14,6	15,1	18,4	19,2	25,2	26,2	28,6	30,1	32,2	33,7	36,2	39,7
	Net weight	4 Tubi/Pipe	Kg	15,5	16,0	19,4	20,2	26,3	27,3	29,8	31,3	33,5	35,0	37,6	41,1
FXE-S	Ref. FAN-DECK		SWP/STD.1/7, SWD/STD.1/7		SWP/STD.1/7, SWD/STD.1/7		SWP/STD.1/7, SWD/STD.1/7		SWP/STD.1/8, SWD/STD.1/8		SWP/STD.1/9, SWD/STD.1/9		SWP/FIX.1/10, SWD/FIXD.2.1/10		
	Peso netto	2 Tubi/Pipe	Kg	15,3	15,8	19,1	19,9	25,9	26,9	29,3	30,8	32,9	34,4	36,9	40,4
	Net weight	4 Tubi/Pipe	Kg	16,2	16,7	20,1	20,9	27,0	28,0	30,5	32,0	34,2	35,7	38,3	41,8
FXE+	Ref. FAN-DECK		SWP/STD.1/10, SWN/STD.1/10		SWP/STD.1/10, SWN/STD.1/10		Non disponibile		Non disponibile		Non disponibile		Non disponibile		
	Peso netto	2 Tubi/Pipe	Kg	15,1	15,6	18,9	19,7	Not available		Not available		Not available			
	Net weight	4 Tubi/Pipe	Kg	16,0	16,5	19,9	20,7	Not available		Not available		Not available			

DN(\*) = Diametro nominale, F = Attacchi idraulici batteria Gas femmina

DN(\*) = Nominal diameter, F = Female gas water coil connections

▪ Peso netto= solo unità, escluso imballo

▪ Net weight= unit only, excluding packaging

# FX-HB

## Versione orizzontale a soffitto (mobile con griglia aspirazione aria frontale) Horizontal ceiling version (cabinet with front air intake grill)

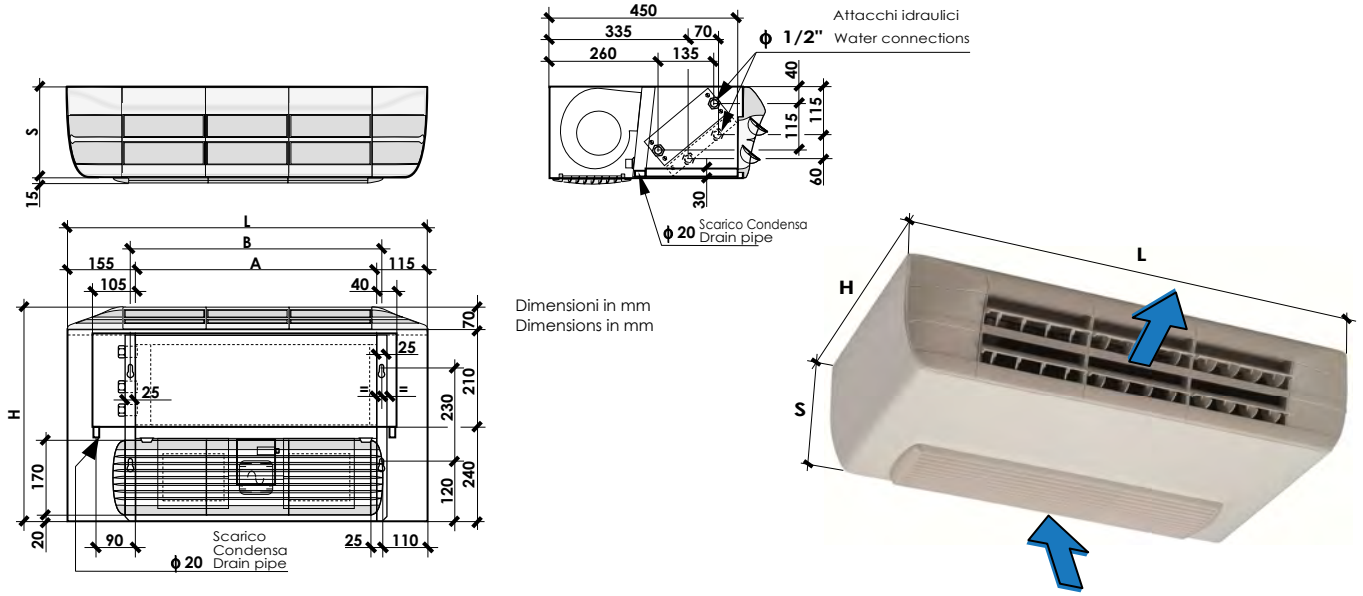

Taglia - Size			DF-X, FXE, ...	100	200	300	400	500	600	700	800	900	1000	1100	1200
Dimensioni principali Main dimensions	L	mm		670	670	870	870	1.070	1.070	1.270	1.270	1.470	1.470	1.670	1.670
	H	mm		520	520	520	520	520	520	520	520	520	520	520	520
	S	mm		220	220	220	220	220	220	220	220	220	220	220	220
	A	mm		400	400	600	600	800	800	1.000	1.000	1.200	1.200	1.400	1.400
	B	mm		425	425	625	625	825	825	1.025	1.025	1.225	1.225	1.425	1.425
N° Motori N° Ventilatori				1	1	1	1	1	1	1	1	1	1	1	1
Batteria caldo/freddo Heating/cooling coil	Contenuto acqua Water volume (l)			0,69	0,70	0,99	1,01	1,30	1,31	1,60	1,62	1,91	1,92	2,21	2,23
	Ranghi - Rows DN(*)			3R 1/2" F	3R 1/2" F	3R 1/2" F	3R 1/2" F	3R 1/2" F	3R 1/2" F	3R 1/2" F	3R 1/2" F	3R 1/2" F	3R 1/2" F	3R 1/2" F	3R 1/2" F
Batteria caldo Heating coil	Contenuto acqua Water volume (l)			0,23	0,23	0,33	0,33	0,43	0,43	0,54	0,54	0,64	0,64	0,74	0,74
	Ranghi - Rows DN(*)			1R 1/2" F	1R 1/2" F	1R 1/2" F	1R 1/2" F	1R 1/2" F	1R 1/2" F	1R 1/2" F	1R 1/2" F	1R 1/2" F	1R 1/2" F	1R 1/2" F	1R 1/2" F
Scarico condensa - Drain pipe		φ(mm)		20	20	20	20	20	20	20	20	20	20	20	20
<b>FX</b>	Ref. FAN-DECK			C2, A40.6V, [P2-3-5],[N1-2-4]	C3.15, A40.6V, [P2-3-5],[N1-2-4]	C3.15, A80.6V, [P2-3-5],[N1-2-4]	C3.15, A80.6V, [P2-3-5],[N1-2-4]	C5, A80.6V, [P2-3-5],[N1-2-4]	C5, A80.6V, [P2-3-5],[N1-2-4]	C3.15, A80.6V, [P2-3-5],[N1-2-4]	C3.15, A80.6V, [P2-3-5],[N1-2-4]	C3.15, A80.6V, [P2-3-5],[N1-2-4]	C3.15, A80.6V, [P2-3-5],[N1-2-4]	C3.15, A80.6V, [P2-3-5],[N1-2-4]	C3.15, A80.6V, [P2-3-5],[N1-2-4]
	Peso netto Net weight	2 Tubi/Pipe 4 Tubi/Pipe	Kg	15,0 15,9	15,5 16,4	18,5 19,5	19,3 20,3	25,2 26,3	26,2 27,3	29,3 30,5	30,8 32,0	33,9 35,2	35,4 36,7	37,4 38,8	40,9 42,3
	Ref. FAN-DECK			C3.15, A40.6V, [P2-3-5],[N1-2-4]	C3.15, A40.6V, [P2-3-5],[N1-2-4]	C3.15, A80.6V, [P2-3-5],[N1-2-4]	C2, A80.6V, [P2-3-5],[N1-2-4]	C4, A80.6V, [P2-3-5],[N1-2-4]	C4, A80.6V, [P2-3-5],[N1-2-4]	C4, A80.6V, [P2-3-5],[N1-2-4]	C4, A80.6V, [P2-3-5],[N1-2-4]	C4, A80.6V, [P2-3-5],[N1-2-4]	C4, A80.6V, [P2-3-5],[N1-2-4]	C4, A80.6V, [P2-3-5],[N1-2-4]	C4, A80.6V, [P2-3-5],[N1-2-4]
<b>FX-P</b>	Ref. FAN-DECK			C3.15, A40.6V, [P2-3-5],[N1-2-4]	C3.15, A40.6V, [P2-3-5],[N1-2-4]	C3.15, A80.6V, [P2-3-5],[N1-2-4]	C2, A80.6V, [P2-3-5],[N1-2-4]	C4, A80.6V, [P2-3-5],[N1-2-4]	C4, A80.6V, [P2-3-5],[N1-2-4]	C4, A80.6V, [P2-3-5],[N1-2-4]	C4, A80.6V, [P2-3-5],[N1-2-4]	C4, A80.6V, [P2-3-5],[N1-2-4]	C4, A80.6V, [P2-3-5],[N1-2-4]	C4, A80.6V, [P2-3-5],[N1-2-4]	C4, A80.6V, [P2-3-5],[N1-2-4]
	Peso netto Net weight	2 Tubi/Pipe 4 Tubi/Pipe	Kg	15,6 16,5	16,1 17,0	19,3 20,3	20,1 21,1	25,7 26,8	26,7 27,8	30,2 31,4	31,7 32,9	35,0 36,3	36,5 37,8	38,5 39,9	42,0 43,4
	Ref. FAN-DECK			C1.5, A40.6V, [P4-5-6],[N4-5-6]	C2.5, A40.6V, [P4-5-6],[N4-5-6]	C2.5, A40.6V, [P4-5-6],[N4-5-6]	C2.5, A80.6V, [P4-5-6],[N4-5-6]	C4, A80.6V, [P4-5-6],[N4-5-6]	C4, A80.6V, [P4-5-6],[N4-5-6]	C2.5, A80.6V, [P4-5-6],[N4-5-6]	C2.5, A80.6V, [P4-5-6],[N4-5-6]	C4, V3-A240, [P4-5-6],[N4-5-6]	C4, V3-A240, [P4-5-6],[N4-5-6]	C4, V3-A240, [P4-5-6],[N4-5-6]	C4, V3-A240, [P4-5-6],[N4-5-6]
<b>FX-S</b>	Ref. FAN-DECK			SWP/STD.1/10, SWN/STD.1/10	SWP/STD.1/10, SWN/STD.1/10	SWP/STD.1/10, SWN/STD.1/10	SWP/STD.1/10, SWN/STD.1/10	SWP/STD.1/10, SWN/STD.1/10	SWP/STD.1/10, SWN/STD.1/10	SWP/STD.1/10, SWN/STD.1/10	SWP/STD.1/10, SWN/STD.1/10	SWP/STD.1/10, SWN/STD.1/10	SWP/STD.1/10, SWN/STD.1/10	SWP/STD.1/10, SWN/STD.1/10	SWP/STD.1/10, SWN/STD.1/10
	Peso netto Net weight	2 Tubi/Pipe 4 Tubi/Pipe	Kg	14,6 15,5	15,1 16,0	18,6 19,6	19,4 20,4	25,6 26,7	26,6 27,7	29,2 30,4	30,7 31,9	33,0 34,3	34,5 35,8	37,2 38,6	40,7 42,1
	Ref. FAN-DECK			SWP/STD.1/10, SWD/STD.1/10	SWP/STD.1/10, SWD/STD.1/10	SWP/STD.1/10, SWD/STD.1/10	SWP/STD.1/10, SWD/STD.1/10	SWP/STD.1/10, SWD/STD.1/10	SWP/STD.1/10, SWD/STD.1/10	SWP/STD.1/10, SWD/STD.1/10	SWP/STD.1/10, SWD/STD.1/10	SWP/STD.1/10, SWD/STD.1/10	SWP/STD.1/10, SWD/STD.1/10	SWP/STD.1/10, SWD/STD.1/10	SWP/STD.1/10, SWD/STD.1/10
<b>FXE</b>	Ref. FAN-DECK			SWP/STD.1/10, SWD/STD.1/10	SWP/STD.1/10, SWD/STD.1/10	SWP/STD.1/10, SWD/STD.1/10	SWP/STD.1/10, SWD/STD.1/10	SWP/STD.1/10, SWD/STD.1/10	SWP/STD.1/10, SWD/STD.1/10	SWP/STD.1/10, SWD/STD.1/10	SWP/STD.1/10, SWD/STD.1/10	SWP/STD.1/10, SWD/STD.1/10	SWP/STD.1/10, SWD/STD.1/10	SWP/STD.1/10, SWD/STD.1/10	SWP/STD.1/10, SWD/STD.1/10
	Peso netto Net weight	2 Tubi/Pipe 4 Tubi/Pipe	Kg	14,9 15,8	15,4 16,3	18,9 19,9	19,7 20,7	25,9 27,0	26,9 28,0	29,5 30,7	31,0 32,2	33,3 34,6	34,8 36,1	37,5 38,9	41,0 42,4
	Ref. FAN-DECK			SWP/STD.1/7, SWD/STD.1/7	SWP/STD.1/7, SWD/STD.1/7	SWP/STD.1/7, SWD/STD.1/7	SWP/STD.1/7, SWD/STD.1/7	SWP/STD.1/7, SWD/STD.1/7	SWP/STD.1/7, SWD/STD.1/7	SWP/STD.1/7, SWD/STD.1/7	SWP/STD.1/7, SWD/STD.1/7	SWP/STD.1/7, SWD/STD.1/7	SWP/STD.1/7, SWD/STD.1/7	SWP/STD.1/7, SWD/STD.1/7	SWP/STD.1/7, SWD/STD.1/7
<b>FXE-P</b>	Ref. FAN-DECK			SWP/STD.1/7, SWD/STD.1/7	SWP/STD.1/7, SWD/STD.1/7	SWP/STD.1/7, SWD/STD.1/7	SWP/STD.1/7, SWD/STD.1/7	SWP/STD.1/7, SWD/STD.1/7	SWP/STD.1/7, SWD/STD.1/7	SWP/STD.1/7, SWD/STD.1/7	SWP/STD.1/7, SWD/STD.1/7	SWP/STD.1/7, SWD/STD.1/7	SWP/STD.1/7, SWD/STD.1/7	SWP/STD.1/7, SWD/STD.1/7	SWP/STD.1/7, SWD/STD.1/7
	Peso netto Net weight	2 Tubi/Pipe 4 Tubi/Pipe	Kg	15,6 16,5	16,1 17,0	19,6 20,6	20,4 21,4	26,6 27,7	27,6 28,7	30,2 31,4	31,7 32,9	34,0 35,3	35,5 36,8	38,2 39,6	41,7 43,1
	Ref. FAN-DECK			SWP/STD.1/10, SWN/STD.1/10	SWP/STD.1/10, SWN/STD.1/10	SWP/STD.1/10, SWN/STD.1/10	SWP/STD.1/10, SWN/STD.1/10	SWP/STD.1/10, SWN/STD.1/10	SWP/STD.1/10, SWN/STD.1/10	SWP/STD.1/10, SWN/STD.1/10	SWP/STD.1/10, SWN/STD.1/10	SWP/STD.1/10, SWN/STD.1/10	SWP/STD.1/10, SWN/STD.1/10	SWP/STD.1/10, SWN/STD.1/10	SWP/STD.1/10, SWN/STD.1/10
<b>FXE-S</b>	Ref. FAN-DECK			SWP/STD.1/10, SWN/STD.1/10	SWP/STD.1/10, SWN/STD.1/10	SWP/STD.1/10, SWN/STD.1/10	SWP/STD.1/10, SWN/STD.1/10	SWP/STD.1/10, SWN/STD.1/10	SWP/STD.1/10, SWN/STD.1/10	SWP/STD.1/10, SWN/STD.1/10	SWP/STD.1/10, SWN/STD.1/10	SWP/STD.1/10, SWN/STD.1/10	SWP/STD.1/10, SWN/STD.1/10	SWP/STD.1/10, SWN/STD.1/10	SWP/STD.1/10, SWN/STD.1/10
	Peso netto Net weight	2 Tubi/Pipe 4 Tubi/Pipe	Kg	15,4 16,3	15,9 16,8	19,4 20,4	20,2 21,2	Non disponibile Not available	Non disponibile Not available	Non disponibile Not available	Non disponibile Not available	Non disponibile Not available	Non disponibile Not available	Non disponibile Not available	Non disponibile Not available
	Ref. FAN-DECK			SWP/STD.1/10, SWN/STD.1/10	SWP/STD.1/10, SWN/STD.1/10	SWP/STD.1/10, SWN/STD.1/10	SWP/STD.1/10, SWN/STD.1/10	SWP/STD.1/10, SWN/STD.1/10	SWP/STD.1/10, SWN/STD.1/10	SWP/STD.1/10, SWN/STD.1/10	SWP/STD.1/10, SWN/STD.1/10	SWP/STD.1/10, SWN/STD.1/10	SWP/STD.1/10, SWN/STD.1/10	SWP/STD.1/10, SWN/STD.1/10	SWP/STD.1/10, SWN/STD.1/10
<b>FXE+</b>	Ref. FAN-DECK			SWP/STD.1/10, SWN/STD.1/10	SWP/STD.1/10, SWN/STD.1/10	SWP/STD.1/10, SWN/STD.1/10	SWP/STD.1/10, SWN/STD.1/10	SWP/STD.1/10, SWN/STD.1/10	SWP/STD.1/10, SWN/STD.1/10	SWP/STD.1/10, SWN/STD.1/10	SWP/STD.1/10, SWN/STD.1/10	SWP/STD.1/10, SWN/STD.1/10	SWP/STD.1/10, SWN/STD.1/10	SWP/STD.1/10, SWN/STD.1/10	SWP/STD.1/10, SWN/STD.1/10
	Peso netto Net weight	2 Tubi/Pipe 4 Tubi/Pipe	Kg	15,4 16,3	15,9 16,8	19,4 20,4	20,2 21,2	Non disponibile Not available	Non disponibile Not available	Non disponibile Not available	Non disponibile Not available	Non disponibile Not available	Non disponibile Not available	Non disponibile Not available	Non disponibile Not available
	Ref. FAN-DECK			SWP/STD.1/10, SWN/STD.1/10	SWP/STD.1/10, SWN/STD.1/10	SWP/STD.1/10, SWN/STD.1/10	SWP/STD.1/10, SWN/STD.1/10	SWP/STD.1/10, SWN/STD.1/10	SWP/STD.1/10, SWN/STD.1/10	SWP/STD.1/10, SWN/STD.1/10	SWP/STD.1/10, SWN/STD.1/10	SWP/STD.1/10, SWN/STD.1/10	SWP/STD.1/10, SWN/STD.1/10	SWP/STD.1/10, SWN/STD.1/10	SWP/STD.1/10, SWN/STD.1/10

DN(\*) = Diametro nominale, F = Attacchi idraulici batteria Gas femmina

DN(\*) = Nominal diameter, F = Female gas water coil connections

▪ Peso netto= solo unità, escluso imballo

▪ Net weight= unit only, excluding packaging

# FX-HC

## Versione orizzontale a soffitto (mobile con zoccolone+griglia aspirazione aria) Horizontal ceiling version (cabinet with air intake feet support+grill)

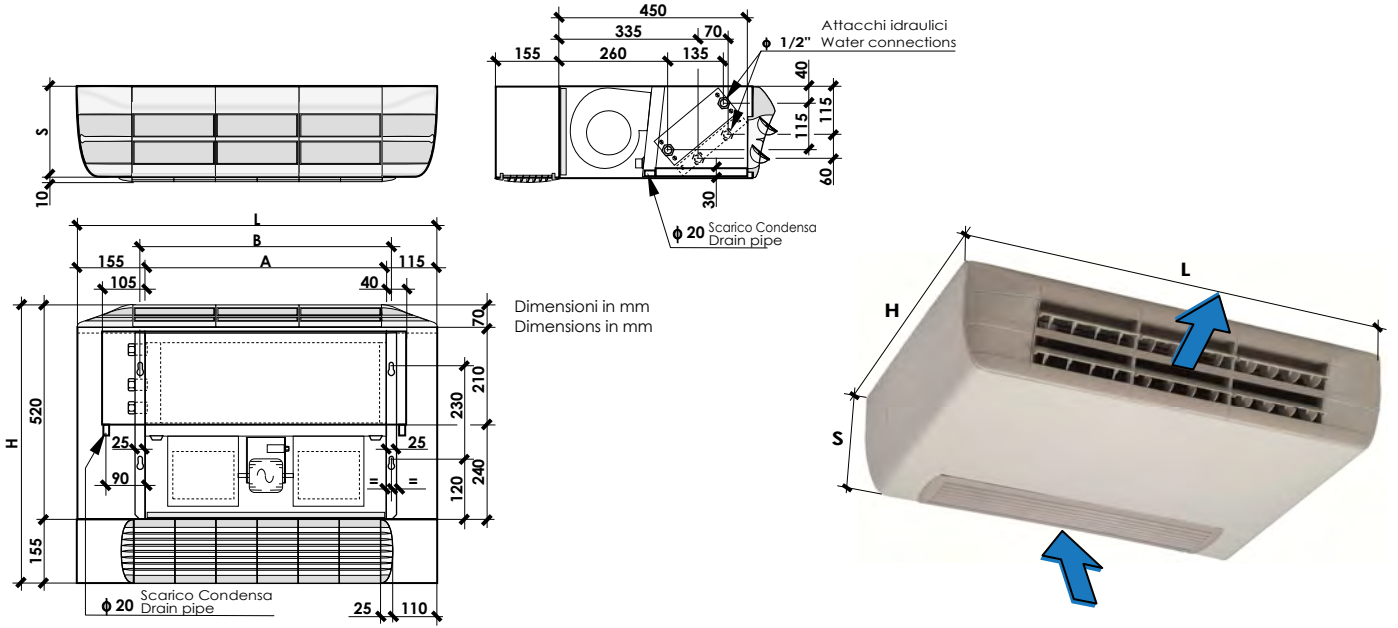

Taglia - Size		DF-X, FXE, ...	100	200	300	400	500	600	700	800	900	1000	1100	1200
Dimensioni principali Main dimensions	L	mm	670	670	870	870	1.070	1.070	1.270	1.270	1.470	1.470	1.670	1.670
	H	mm	675	675	675	675	675	675	675	675	675	675	675	675
	S	mm	220	220	220	220	220	220	220	220	220	220	220	220
	A	mm	400	400	600	600	800	800	1.000	1.000	1.200	1.200	1.400	1.400
	B	mm	425	425	625	625	825	825	1.025	1.025	1.225	1.225	1.425	1.425
N° Motori			1	1	1	1	1	1	1	1	1	1	1	1
N° Ventilatori			1	1	1	1	2	2	2	2	2	2	3	3
Batteria caldo/freddo Heating/cooling coil	Contenuto acqua Water volume (l)		0,69	0,70	0,99	1,01	1,30	1,31	1,60	1,62	1,91	1,92	2,21	2,23
	Ranghi - Rows DN(*)		3R 1/2" F	3R 1/2" F	3R 1/2" F	3R 1/2" F	3R 1/2" F	3R 1/2" F	3R 1/2" F	3R 1/2" F	3R 1/2" F	3R 1/2" F	3R 1/2" F	3R 1/2" F
Batteria caldo Heating coil	Contenuto acqua Water volume (l)		0,23	0,23	0,33	0,33	0,43	0,43	0,54	0,54	0,64	0,64	0,74	0,74
	Ranghi - Rows DN(*)		1R 1/2" F	1R 1/2" F	1R 1/2" F	1R 1/2" F	1R 1/2" F	1R 1/2" F	1R 1/2" F	1R 1/2" F	1R 1/2" F	1R 1/2" F	1R 1/2" F	1R 1/2" F
Scarico condensa - Drain pipe			φ(mm)	20	20	20	20	20	20	20	20	20	20	20
FX	Ref. FAN-DECK		C2. A40.6V. [P2-3-5],[N1-2-4]		C3.15. A40.6V. [P2-3-5],[N1-2-4]		C3.15. A80.6V. [P2-3-5],[N1-2-4]		C5. A80.6V. [P2-3-5],[N1-2-4]		C3.15. A80.6V. [P2-3-5],[N1-2-4]		C3.15. 5V. [P2-3-4],[ND.1-3-4]	
	Peso netto	2 Tubi/Pipe	Kg	16,2	16,7	19,8	20,6	26,6	27,6	30,8	32,3	35,5	37,0	39,1
	Net weight	4 Tubi/Pipe	Kg	17,1	17,6	20,8	21,6	27,7	28,7	32,0	33,5	36,8	38,3	40,5
FX-P	Ref. FAN-DECK		C3.15. A40.6V. [P2-3-5],[N1-2-4]		C3.15. A80.6V. [P2-3-5],[N1-2-4]		C2. A80.6V. [P2-3-5],[N1-2-4]		C4. A80.6V. [P2-3-5],[N1-2-4]		C4. 6V. [P2-3-4],[N1-3-5]		C4. 5V. [P2-3-4],[N1-3-4]	
	Peso netto	2 Tubi/Pipe	Kg	16,8	17,3	20,6	21,4	27,1	28,1	31,7	33,2	36,6	38,1	40,2
	Net weight	4 Tubi/Pipe	Kg	17,7	18,2	21,6	22,4	28,2	29,2	32,9	34,4	37,9	39,4	41,6
FX-S	Ref. FAN-DECK		C1.5. A40.6V. [P4-5-6],[N4-5-6]		C2.5. A40.6V. [P4-5-6],[N4-5-6]		C2.5. A80.6V. [P4-5-6],[N4-5-6]		C4. A80.6V. [P4-5-6],[N4-5-6]		C2.5. A80.6V. [P4-5-6],[N4-5-6]		C4. V3-A240. [P4-5-6],[N4-5-6]	
	Peso netto	2 Tubi/Pipe	Kg	16,9	17,4	20,5	21,3	27,3	28,3	31,5	33,0	36,2	37,7	39,8
	Net weight	4 Tubi/Pipe	Kg	17,8	18,3	21,5	22,3	28,4	29,4	32,7	34,2	37,5	39,0	41,2
FXE	Ref. FAN-DECK		SWP/STD.1/10. SWN/STD.1/10		SWP/STD.1/10. SWN/STD.1/10		SWP/STD.1/10. SWN/Pot1.1/10		SWP/STD.1/10. SWN/Pot1D.1/10		SWP/STD.1/10. SWN/Pot1.1/10		SWP/FIX.1/10. SWD/FIXD1.1/10	
	Peso netto	2 Tubi/Pipe	Kg	15,8	16,3	19,9	20,7	27,0	28,0	30,7	32,2	34,6	36,1	38,9
	Net weight	4 Tubi/Pipe	Kg	16,7	17,2	20,9	21,7	28,1	29,1	31,9	33,4	35,9	37,4	40,3
FXE-P	Ref. FAN-DECK		SWP/STD.1/10. SWD/STD.1/10		SWP/STD.1/10. SWD/STD.1/10		SWP/Pot1.1/10. SWD/Pot1.1/10		SWP/Pot1.1/10. SWD/Pot1.1/10		SWP/FIX.1/10. SWD/FIX.1/10		SWP/FIX.1/10. SWD/FIXD1.1/10	
	Peso netto	2 Tubi/Pipe	Kg	16,1	16,6	20,2	21,0	27,3	28,3	31,0	32,5	34,9	36,4	39,2
	Net weight	4 Tubi/Pipe	Kg	17,0	17,5	21,2	22,0	28,4	29,4	32,2	33,7	36,2	37,7	40,6
FXE-S	Ref. FAN-DECK		SWP/STD.1/7. SWD/STD.1/7		SWP/STD.1/7. SWD/STD.1/7		SWP/STD.1/7. SWD/STD.1/7		SWP/STD.1/8. SWD/STD.1/8		SWP/STD.1/9. SWD/STD.1/9		SWP/FIX.1/10. SWD/FIXD2.1/10	
	Peso netto	2 Tubi/Pipe	Kg	16,8	17,3	20,9	21,7	28,0	29,0	31,7	33,2	35,6	37,1	39,9
	Net weight	4 Tubi/Pipe	Kg	17,7	18,2	21,9	22,7	28,1	29,1	32,9	34,4	36,9	38,4	41,3
FXE+	Ref. FAN-DECK		SWP/STD.1/10. SWN/STD.1/10		SWP/STD.1/10. SWN/STD.1/10		Non disponibile		Non disponibile		Non disponibile		Non disponibile	
	Peso netto	2 Tubi/Pipe	Kg	16,6	17,1	20,7	21,5	Not available		Not available		Not available		
	Net weight	4 Tubi/Pipe	Kg	17,5	18,0	21,7	22,5	Not available		Not available		Not available		

DN(\*) = Diametro nominale, F = Attacchi idraulici batteria Gas femmina

DN(\*) = Nominal diameter, F = Female gas water coil connections

▪ Peso netto= solo unità, escluso imballo

▪ Net weight= unit only, excluding packaging

## Versione Incasso verticale (base; senza mobile) Vertical concealed version (basic; without cabinet)

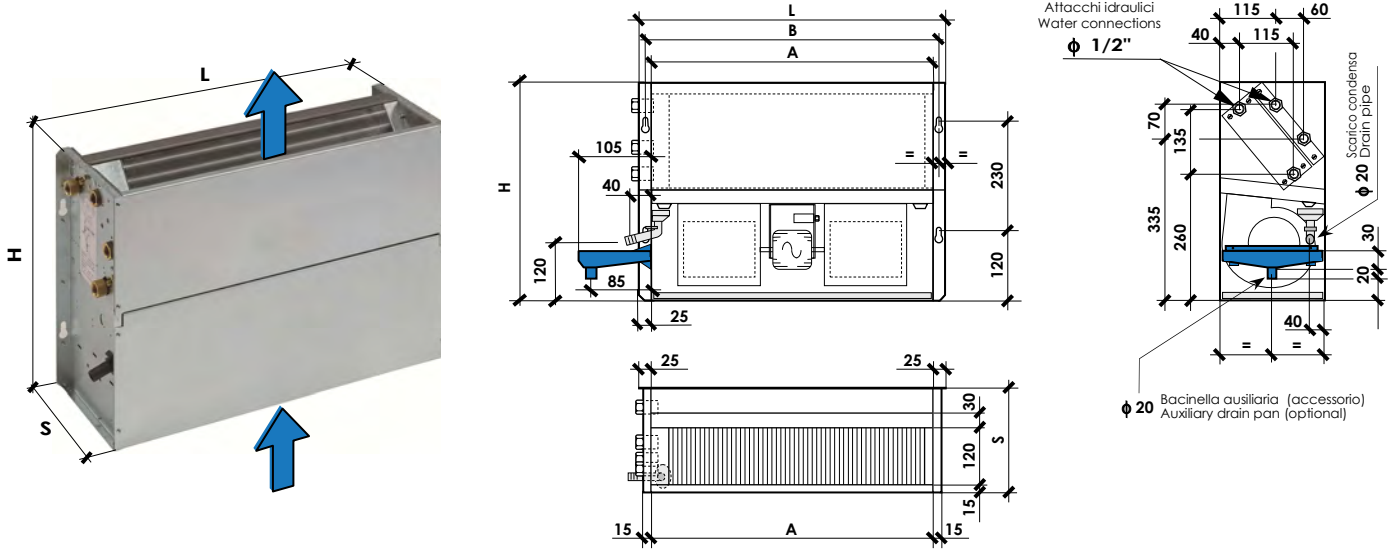

Taglia - Size			DF-X, FXE, ...	100	200	300	400	500	600	700	800	900	1000	1100	1200
Dimensioni principali Main dimensions	L	mm		450	450	650	650	850	850	1050	1050	1250	1250	1450	1450
	H	mm		450	450	450	450	450	450	450	450	450	450	450	450
	S	mm		215	215	215	215	215	215	215	215	215	215	215	215
	A	mm		400	400	600	600	800	800	1.000	1.000	1.200	1.200	1.400	1.400
	B	mm		425	425	625	625	825	825	1.025	1.025	1.225	1.225	1.425	1.425
N° Motori				1	1	1	1	1	1	1	1	1	1	1	1
N° Ventilatori				1	1	1	1	2	2	2	2	2	2	3	3
Batteria caldo/freddo Heating/cooling coil	Contenuto acqua Water volume (l)			0,69	0,70	0,99	1,01	1,30	1,31	1,60	1,62	1,91	1,92	2,21	2,23
	Ranghi - Rows DN(*)			3R 1/2" F	3R 1/2" F	3R 1/2" F	3R 1/2" F	3R 1/2" F	3R 1/2" F	3R 1/2" F	3R 1/2" F	3R 1/2" F	3R 1/2" F	3R 1/2" F	3R 1/2" F
Batteria caldo Heating coil	Contenuto acqua Water volume (l)			0,23	0,23	0,33	0,33	0,43	0,43	0,54	0,54	0,64	0,64	0,74	0,74
	Ranghi - Rows DN(*)			1R 1/2" F	1R 1/2" F	1R 1/2" F	1R 1/2" F	1R 1/2" F	1R 1/2" F	1R 1/2" F	1R 1/2" F	1R 1/2" F	1R 1/2" F	1R 1/2" F	1R 1/2" F
Scarico condensa - Drain pipe			φ(mm)	20	20	20	20	20	20	20	20	20	20	20	20
FX	Ref. FAN-DECK			C2, A40.6V, [P2-3-5],[N1-2-4]	C3.15, A40.6V, [P2-3-5],[N1-2-4]	C3.15, A40.6V, [P2-3-5],[N1-2-4]	C3.15, A40.6V, [P2-3-5],[N1-2-4]	C3.15, A80.6V, [P2-3-5],[N1-2-4]	C3.15, A80.6V, [P2-3-5],[N1-2-4]	C5, A80.6V, [P2-3-5],[N1-2-4]	C5, A80.6V, [P2-3-5],[N1-2-4]	C3.15, A80.6V, [P2-3-5],[N1-2-4]	C3.15, A80.6V, [P2-3-5],[N1-2-4]	C3.15, 5V, [P2-3-4],[ND.1-3-4]	C3.15, 5V, [P2-3-4],[ND.1-3-4]
	Peso netto	2 Tubi/Pipe	Kg	10,7	11,2	13,5	14,3	19,5	20,5	22,9	24,4	26,8	28,3	29,6	33,1
	Net weight	4 Tubi/Pipe	Kg	11,6	12,1	14,5	15,3	20,6	21,6	24,1	25,6	28,1	29,6	31,0	34,5
FX-P	Ref. FAN-DECK			C3.15, A40.6V, [P2-3-5],[N1-2-4]	C3.15, A80.6V, [P2-3-5],[N1-2-4]	C2, A80.6V, [P2-3-5],[N1-2-4]	C2, A80.6V, [P2-3-5],[N1-2-4]	C4, A80.6V, [P2-3-5],[N1-2-4]	C4, A80.6V, [P2-3-5],[N1-2-4]	C4, 6V, [P2-3-4],[N1-3-5]	C4, 6V, [P2-3-4],[N1-3-5]	C4, 5V, [P2-3-4],[N1-3-4]	C4, 5V, [P2-3-4],[N1-3-4]	C4, 5V, [P2-3-4],[N1-3-4]	C4, 5V, [P2-3-4],[N1-3-4]
	Peso netto	2 Tubi/Pipe	Kg	11,3	11,8	14,3	15,1	20,0	21,0	23,8	25,3	27,9	29,4	30,7	34,2
	Net weight	4 Tubi/Pipe	Kg	12,2	12,7	15,3	16,1	21,1	22,1	25,0	26,5	29,2	30,7	32,1	35,6
FX-S	Ref. FAN-DECK			C1.5, A40.6V, [P4-5-6],[N4-5-6]	C2.5, A40.6V, [P4-5-6],[N4-5-6]	C2.5, A40.6V, [P4-5-6],[N4-5-6]	C2.5, A40.6V, [P4-5-6],[N4-5-6]	C2.5, A80.6V, [P4-5-6],[N4-5-6]	C2.5, A80.6V, [P4-5-6],[N4-5-6]	C4, A80.6V, [P4-5-6],[N4-5-6]	C4, A80.6V, [P4-5-6],[N4-5-6]	C2.5, A80.6V, [P4-5-6],[N4-5-6]	C2.5, A80.6V, [P4-5-6],[N4-5-6]	C4, V3-A240, [P4-5-6],[N4-5-6]	C4, V3-A240, [P4-5-6],[N4-5-6]
	Peso netto	2 Tubi/Pipe	Kg	11,4	11,9	14,2	15,0	20,2	21,2	23,6	25,1	27,5	29,0	30,3	33,8
	Net weight	4 Tubi/Pipe	Kg	12,3	12,8	15,2	16,0	21,3	22,3	24,8	26,3	28,8	30,3	31,7	35,2
FXE	Ref. FAN-DECK			SWP/STD.1/10, SWN/STD.1/10	SWP/STD.1/10, SWN/STD.1/10	SWP/STD.1/10, SWN/STD.1/10	SWP/STD.1/10, SWN/STD.1/10	SWP/STD.1/10, SWN/STD.1/10	SWP/STD.1/10, SWN/STD.1/10	SWP/STD.1/10, SWN/STD.1/10	SWP/STD.1/10, SWN/STD.1/10	SWP/STD.1/10, SWN/STD.1/10	SWP/STD.1/10, SWN/STD.1/10	SWP/STD.1/10, SWN/STD.1/10	SWP/STD.1/10, SWN/STD.1/10
	Peso netto	2 Tubi/Pipe	Kg	10,3	10,8	13,6	14,4	19,9	20,9	22,8	24,3	25,9	27,4	29,4	32,9
	Net weight	4 Tubi/Pipe	Kg	11,2	11,7	14,6	15,4	21,0	22,0	24,0	25,5	27,2	28,7	30,8	34,3
FXE-P	Ref. FAN-DECK			SWP/STD.1/10, SWD/STD.1/10	SWP/STD.1/10, SWD/STD.1/10	SWP/STD.1/10, SWD/STD.1/10	SWP/STD.1/10, SWD/STD.1/10	SWP/STD.1/10, SWD/STD.1/10	SWP/STD.1/10, SWD/STD.1/10	SWP/STD.1/10, SWD/STD.1/10	SWP/STD.1/10, SWD/STD.1/10	SWP/STD.1/10, SWD/STD.1/10	SWP/STD.1/10, SWD/STD.1/10	SWP/STD.1/10, SWD/STD.1/10	SWP/STD.1/10, SWD/STD.1/10
	Peso netto	2 Tubi/Pipe	Kg	10,6	11,1	13,9	14,7	20,2	21,2	23,1	24,6	26,2	27,7	29,7	33,2
	Net weight	4 Tubi/Pipe	Kg	11,5	12,0	14,9	15,7	21,3	22,3	24,3	25,8	27,5	29,0	31,1	34,6
FXE-S	Ref. FAN-DECK			SWP/STD.1/7, SWD/STD.1/7	SWP/STD.1/7, SWD/STD.1/7	SWP/STD.1/7, SWD/STD.1/7	SWP/STD.1/7, SWD/STD.1/7	SWP/STD.1/7, SWD/STD.1/7	SWP/STD.1/7, SWD/STD.1/7	SWP/STD.1/8, SWD/STD.1/8	SWP/STD.1/8, SWD/STD.1/8	SWP/STD.1/9, SWD/STD.1/9	SWP/STD.1/9, SWD/STD.1/9	SWP/STD.1/9, SWD/STD.1/9	SWP/STD.1/9, SWD/STD.1/9
	Peso netto	2 Tubi/Pipe	Kg	11,3	11,8	14,6	15,4	20,9	21,9	23,8	25,3	26,9	28,4	30,4	33,9
	Net weight	4 Tubi/Pipe	Kg	12,2	12,7	15,6	16,4	22,0	23,0	25,0	26,5	28,2	29,7	31,8	35,3
FXE+	Ref. FAN-DECK			SWP/STD.1/10, SWN/STD.1/10	SWP/STD.1/10, SWN/STD.1/10	SWP/STD.1/10, SWN/STD.1/10	SWP/STD.1/10, SWN/STD.1/10	Non disponibile	Non disponibile	Non disponibile	Non disponibile	Non disponibile	Non disponibile	Non disponibile	Non disponibile
	Peso netto	2 Tubi/Pipe	Kg	11,1	11,6	14,4	15,2	Non disponibile	Non disponibile	Non disponibile	Non disponibile	Non disponibile	Non disponibile	Non disponibile	Non disponibile
	Net weight	4 Tubi/Pipe	Kg	12,0	12,5	15,4	16,2	Non disponibile	Non disponibile	Non disponibile	Non disponibile	Non disponibile	Non disponibile	Non disponibile	Non disponibile

DN(\*) = Diametro nominale, F = Attacchi idraulici batteria Gas femmina

DN(\*) = Nominal diameter, F = Female gas water coil connections

• Peso netto= solo unità, escluso imballo

• Net weight= unit only, excluding packaging

# FX-CB

## Versione incasso verticale (aspirazione aria frontale; senza mobile) Vertical concealed version (front air intake; without cabinet)

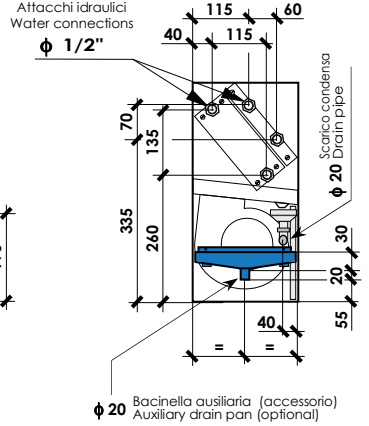
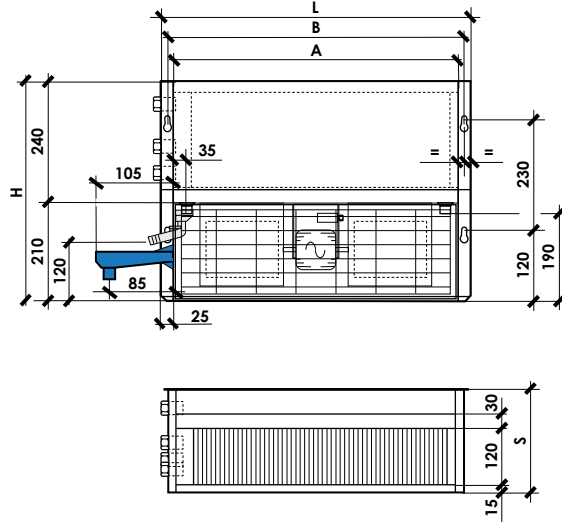
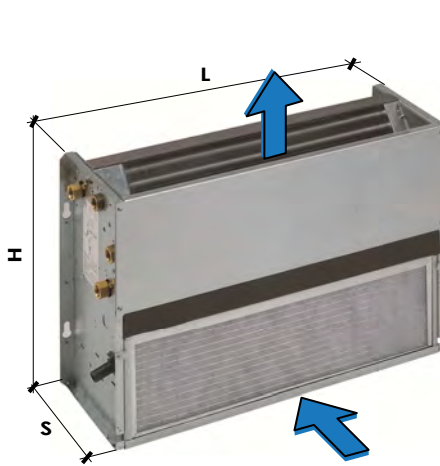

Taglia - Size			DF-X, FXE, ...	100	200	300	400	500	600	700	800	900	1000	1100	1200
Dimensioni principali Main dimensions	L	mm		450	450	650	650	850	850	1050	1050	1250	1250	1450	1450
	H	mm		450	450	450	450	450	450	450	450	450	450	450	450
	S	mm		215	215	215	215	215	215	215	215	215	215	215	215
	A	mm		400	400	600	600	800	800	1.000	1.000	1.200	1.200	1.400	1.400
	B	mm		425	425	625	625	825	825	1.025	1.025	1.225	1.225	1.425	1.425
N° Motori				1	1	1	1	1	1	1	1	1	1	1	1
N° Ventilatori				1	1	1	1	2	2	2	2	2	2	3	3
Batteria caldo/freddo Heating/cooling coil	Contenuto acqua Water volume (l)			0,69	0,70	0,99	1,01	1,30	1,31	1,60	1,62	1,91	1,92	2,21	2,23
	Ranghi - Rows DN(*)			3R 1/2" F	3R 1/2" F	3R 1/2" F	3R 1/2" F	3R 1/2" F	3R 1/2" F	3R 1/2" F	3R 1/2" F	3R 1/2" F	3R 1/2" F	3R 1/2" F	3R 1/2" F
Batteria caldo Heating coil	Contenuto acqua Water volume (l)			0,23	0,23	0,33	0,33	0,43	0,43	0,54	0,54	0,64	0,64	0,74	0,74
	Ranghi - Rows DN(*)			1R 1/2" F	1R 1/2" F	1R 1/2" F	1R 1/2" F	1R 1/2" F	1R 1/2" F	1R 1/2" F	1R 1/2" F	1R 1/2" F	1R 1/2" F	1R 1/2" F	1R 1/2" F
Scarico condensa - Drain pipe			φ(mm)	20	20	20	20	20	20	20	20	20	20	20	20
FX	Ref. FAN-DECK			C2, A40.6V, [P2-3-5],[N1-2-4]	C3.15, A40.6V, [P2-3-5],[N1-2-4]	C3.15, A40.6V, [P2-3-5],[N1-2-4]	C3.15, A40.6V, [P2-3-5],[N1-2-4]	C3.15, A80.6V, [P2-3-5],[N1-2-4]	C3.15, A80.6V, [P2-3-5],[N1-2-4]	C5, A80.6V, [P2-3-5],[N1-2-4]	C5, A80.6V, [P2-3-5],[N1-2-4]	C3.15, A80.6V, [P2-3-5],[N1-2-4]	C3.15, 5V, [P2-3-4],[ND.1-3-4]	C3.15, 5V, [P2-3-4],[ND.1-3-4]	C3.15, 5V, [P2-3-4],[ND.1-3-4]
	Peso netto	2 Tubi/Pipe	Kg	10,6	11,1	13,4	14,2	19,4	20,4	22,7	24,2	26,6	28,1	29,4	32,9
	Net weight	4 Tubi/Pipe	Kg	11,5	12,0	14,4	15,2	20,5	21,5	23,9	25,4	27,9	29,4	30,8	34,3
FX-P	Ref. FAN-DECK			C3.15, A40.6V, [P2-3-5],[N1-2-4]	C3.15, A80.6V, [P2-3-5],[N1-2-4]	C2, A80.6V, [P2-3-5],[N1-2-4]	C2, A80.6V, [P2-3-5],[N1-2-4]	C4, A80.6V, [P2-3-5],[N1-2-4]	C4, A80.6V, [P2-3-5],[N1-2-4]	C4, 6V, [P2-3-4],[N1-3-5]	C4, 6V, [P2-3-4],[N1-3-5]	C4, 5V, [P2-3-4],[N1-3-4]	C4, 5V, [P2-3-4],[N1-3-4]	C4, 5V, [P2-3-4],[N1-3-4]	C4, 5V, [P2-3-4],[N1-3-4]
	Peso netto	2 Tubi/Pipe	Kg	11,2	11,7	14,2	15,0	19,9	20,9	23,6	25,1	27,7	29,2	30,5	34,0
	Net weight	4 Tubi/Pipe	Kg	12,1	12,6	15,2	16,0	21,0	22,0	24,8	26,3	29,0	30,5	31,9	35,4
FX-S	Ref. FAN-DECK			C1.5, A40.6V, [P4-5-6],[N4-5-6]	C2.5, A40.6V, [P4-5-6],[N4-5-6]	C2.5, A40.6V, [P4-5-6],[N4-5-6]	C2.5, A40.6V, [P4-5-6],[N4-5-6]	C2.5, A80.6V, [P4-5-6],[N4-5-6]	C2.5, A80.6V, [P4-5-6],[N4-5-6]	C4, A80.6V, [P4-5-6],[N4-5-6]	C4, A80.6V, [P4-5-6],[N4-5-6]	C2.5, A80.6V, [P4-5-6],[N4-5-6]	C4, V3-A240, [P4-5-6],[N4-5-6]	C4, V3-A240, [P4-5-6],[N4-5-6]	C4, V3-A240, [P4-5-6],[N4-5-6]
	Peso netto	2 Tubi/Pipe	Kg	11,3	11,8	14,1	14,9	20,1	21,1	23,4	24,9	27,3	28,8	30,1	33,6
	Net weight	4 Tubi/Pipe	Kg	12,2	12,7	15,1	15,9	21,2	22,2	24,6	26,1	28,6	30,1	31,5	35,0
FXE	Ref. FAN-DECK			SWP/STD.1/10, SWN/STD.1/10	SWP/STD.1/10, SWN/STD.1/10	SWP/STD.1/10, SWN/STD.1/10	SWP/STD.1/10, SWN/STD.1/10	SWP/STD.1/10, SWN/STD.1/10	SWP/STD.1/10, SWN/STD.1/10	SWP/STD.1/10, SWN/STD.1/10	SWP/STD.1/10, SWN/STD.1/10	SWP/STD.1/10, SWN/STD.1/10	SWP/STD.1/10, SWN/STD.1/10	SWP/STD.1/10, SWN/STD.1/10	SWP/STD.1/10, SWN/STD.1/10
	Peso netto	2 Tubi/Pipe	Kg	10,2	10,7	13,5	14,3	19,8	20,8	22,6	24,1	25,7	27,2	29,2	32,7
	Net weight	4 Tubi/Pipe	Kg	11,1	11,6	14,5	15,3	20,9	21,9	23,8	25,3	27,0	28,5	30,6	34,1
FXE-P	Ref. FAN-DECK			SWP/STD.1/10, SWD/STD.1/10	SWP/STD.1/10, SWD/STD.1/10	SWP/STD.1/10, SWD/STD.1/10	SWP/STD.1/10, SWD/STD.1/10	SWP/STD.1/10, SWD/STD.1/10	SWP/STD.1/10, SWD/STD.1/10	SWP/STD.1/10, SWD/STD.1/10	SWP/STD.1/10, SWD/STD.1/10	SWP/STD.1/10, SWD/STD.1/10	SWP/STD.1/10, SWD/STD.1/10	SWP/STD.1/10, SWD/STD.1/10	SWP/STD.1/10, SWD/STD.1/10
	Peso netto	2 Tubi/Pipe	Kg	10,5	11,0	13,8	14,6	20,1	21,1	22,9	24,4	26,0	27,5	29,5	33,0
	Net weight	4 Tubi/Pipe	Kg	11,4	11,9	14,8	15,6	21,2	22,2	24,1	25,6	27,3	28,8	30,9	34,4
FXE-S	Ref. FAN-DECK			SWP/STD.1/7, SWD/STD.1/7	SWP/STD.1/7, SWD/STD.1/7	SWP/STD.1/7, SWD/STD.1/7	SWP/STD.1/7, SWD/STD.1/7	SWP/STD.1/7, SWD/STD.1/7	SWP/STD.1/7, SWD/STD.1/7	SWP/STD.1/8, SWD/STD.1/8	SWP/STD.1/8, SWD/STD.1/8	SWP/STD.1/9, SWD/STD.1/9	SWP/STD.1/9, SWD/STD.1/9	SWP/STD.1/9, SWD/STD.1/9	SWP/STD.1/9, SWD/STD.1/9
	Peso netto	2 Tubi/Pipe	Kg	11,2	11,7	14,5	15,3	20,8	21,8	23,6	25,1	26,7	28,2	30,2	33,7
	Net weight	4 Tubi/Pipe	Kg	12,1	12,6	15,5	16,3	21,9	22,9	24,8	26,3	28,0	29,5	31,6	35,1
FXE+	Ref. FAN-DECK			SWP/STD.1/10, SWN/STD.1/10	SWP/STD.1/10, SWN/STD.1/10	SWP/STD.1/10, SWN/STD.1/10	SWP/STD.1/10, SWN/STD.1/10	SWP/STD.1/10, SWN/STD.1/10	SWP/STD.1/10, SWN/STD.1/10	SWP/STD.1/10, SWN/STD.1/10	SWP/STD.1/10, SWN/STD.1/10	SWP/STD.1/10, SWN/STD.1/10	SWP/STD.1/10, SWN/STD.1/10	SWP/STD.1/10, SWN/STD.1/10	SWP/STD.1/10, SWN/STD.1/10
	Peso netto	2 Tubi/Pipe	Kg	11,0	11,5	14,3	15,1	Non disponibile	Non disponibile	Non disponibile	Non disponibile	Non disponibile	Non disponibile	Non disponibile	Non disponibile
	Net weight	4 Tubi/Pipe	Kg	11,9	12,4	15,3	16,1	Non disponibile	Non disponibile	Non disponibile	Non disponibile	Non disponibile	Non disponibile	Non disponibile	

DN(\*) = Diametro nominale, F = Attacchi idraulici batteria Gas femmina

DN(\*) = Nominal diameter, F = Female gas water coil connections

• Peso netto= solo unità, escluso imballo

• Net weight= unit only, excluding packaging

## Versione incasso verticale (mandata aria frontale; senza mobile) Vertical concealed version (front air supply; without cabinet)

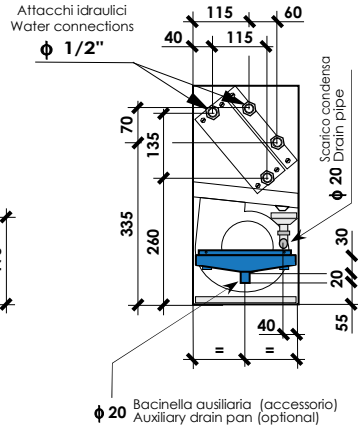
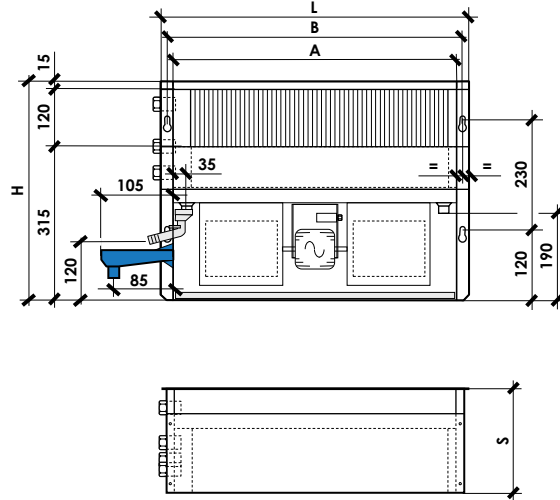
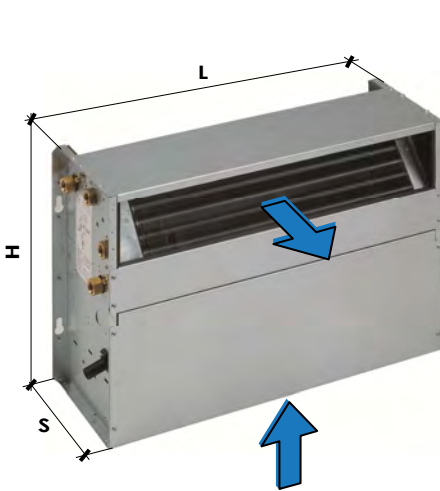

Taglia - Size			DF-X, FXE, ...	100	200	300	400	500	600	700	800	900	1000	1100	1200
Dimensioni principali Main dimensions	L	mm		450	450	650	650	850	850	1050	1050	1250	1250	1450	1450
	H	mm		450	450	450	450	450	450	450	450	450	450	450	450
	S	mm		215	215	215	215	215	215	215	215	215	215	215	215
	A	mm		400	400	600	600	800	800	1.000	1.000	1.200	1.200	1.400	1.400
	B	mm		425	425	625	625	825	825	1.025	1.025	1.225	1.225	1.425	1.425
N° Motori N° Ventilatori				1	1	1	1	1	1	1	1	1	1	1	1
Batteria caldo/freddo Heating/cooling coil	Contenuto acqua Water volume (l)			0,69	0,70	0,99	1,01	1,30	1,31	1,60	1,62	1,91	1,92	2,21	2,23
	Ranghi - Rows DN(*)			3R 1/2" F	3R 1/2" F	3R 1/2" F	3R 1/2" F	3R 1/2" F	3R 1/2" F	3R 1/2" F	3R 1/2" F	3R 1/2" F	3R 1/2" F	3R 1/2" F	3R 1/2" F
Batteria caldo Heating coil	Contenuto acqua Water volume (l)			0,23	0,23	0,33	0,33	0,43	0,43	0,54	0,54	0,64	0,64	0,74	0,74
	Ranghi - Rows DN(*)			1R 1/2" F	1R 1/2" F	1R 1/2" F	1R 1/2" F	1R 1/2" F	1R 1/2" F	1R 1/2" F	1R 1/2" F	1R 1/2" F	1R 1/2" F	1R 1/2" F	1R 1/2" F
Scarico condensa - Drain pipe			φ(mm)	20	20	20	20	20	20	20	20	20	20	20	20
FX	Ref. FAN-DECK			C2, A40.6V, [P2-3-5],[N1-2-4]		C3.15, A40.6V, [P2-3-5],[N1-2-4]		C3.15, A80.6V, [P2-3-5],[N1-2-4]		C5, A80.6V, [P2-3-5],[N1-2-4]		C3.15, A80.6V, [P2-3-5],[N1-2-4]		C3.15, 5V, [P2-3-4],[ND1-3-4]	
	Peso netto	2 Tubi/Pipe	Kg	11,1	11,6	14,1	14,9	20,3	21,3	23,9	25,4	28,0	29,5	31,0	34,5
	Net weight	4 Tubi/Pipe	Kg	12,0	12,5	15,1	15,9	21,4	22,4	25,1	26,6	29,3	30,8	32,4	35,9
FX-P	Ref. FAN-DECK			C3.15, A40.6V, [P2-3-5],[N1-2-4]		C3.15, A80.6V, [P2-3-5],[N1-2-4]		C2, A80.6V, [P2-3-5],[N1-2-4]		C4, A80.6V, [P2-3-5],[N1-2-4]		C4, 6V, [P2-3-4],[N1-3-5]		C4, 5V, [P2-3-4],[N1-3-4]	
	Peso netto	2 Tubi/Pipe	Kg	11,7	12,2	14,9	15,7	20,8	21,8	24,8	26,3	29,1	30,6	32,1	35,6
	Net weight	4 Tubi/Pipe	Kg	12,6	13,1	15,9	16,7	21,9	22,9	26,0	27,5	30,4	31,9	33,5	37,0
FX-S	Ref. FAN-DECK			C1.5, A40.6V, [P4-5-6],[N4-5-6]		C2.5, A40.6V, [P4-5-6],[N4-5-6]		C2.5, A80.6V, [P4-5-6],[N4-5-6]		C4, A80.6V, [P4-5-6],[N4-5-6]		C2.5, A80.6V, [P4-5-6],[N4-5-6]		C4, V3-A240, [P4-5-6],[N4-5-6]	
	Peso netto	2 Tubi/Pipe	Kg	11,8	12,3	14,8	15,6	21,0	22,0	24,6	26,1	28,7	30,2	31,7	35,2
	Net weight	4 Tubi/Pipe	Kg	12,7	13,2	15,8	16,6	22,1	23,1	25,8	27,3	30,0	31,5	33,1	36,6
FXE	Ref. FAN-DECK			SWP/STD.1/10, SWN/STD.1/10		SWP/STD.1/10, SWN/STD.1/10		SWP/STD.1/10, SWN/Pot1.D.1/10		SWP/STD.1/10, SWN/Pot1.D.1/10		SWP/STD.1/10, SWN/Pot1.1/10		SWP/RFX.1/10, SWD/RXD1.1/10	
	Peso netto	2 Tubi/Pipe	Kg	10,7	11,2	14,2	15,0	20,7	21,7	23,8	25,3	27,1	28,6	30,8	34,3
	Net weight	4 Tubi/Pipe	Kg	11,6	12,1	15,2	16,0	21,8	22,8	25,0	26,5	28,4	29,9	32,2	35,7
FXE-P	Ref. FAN-DECK			SWP/STD.1/10, SWD/STD.1/10		SWP/STD.1/10, SWD/STD.1/10		SWP/Pot1.1/10, SWD/Pot1.1/10		SWP/Pot1.1/10, SWD/Pot1.1/10		SWP/RFX.1/10, SWD/RFX.1/10		SWP/RFX.1/10, SWD/RXD1.1/10	
	Peso netto	2 Tubi/Pipe	Kg	11,0	11,5	14,5	15,3	21,0	22,0	24,1	25,6	27,4	28,9	31,1	34,6
	Net weight	4 Tubi/Pipe	Kg	11,9	12,4	15,5	16,3	22,1	23,1	25,3	26,8	28,7	30,2	32,5	36,0
FXE-S	Ref. FAN-DECK			SWP/STD.1/7, SWD/STD.1/7		SWP/STD.1/7, SWD/STD.1/7		SWP/STD.1/7, SWD/STD.1/7		SWP/STD.1/8, SWD/STD.1/8		SWP/STD.1/9, SWD/STD.1/9		SWP/RFX.1/10, SWD/RXD2.1/10	
	Peso netto	2 Tubi/Pipe	Kg	11,7	12,2	15,2	16,0	21,7	22,7	24,8	26,3	28,1	29,6	31,8	35,3
	Net weight	4 Tubi/Pipe	Kg	12,6	13,1	16,2	17,0	22,8	23,8	26,0	27,5	29,4	30,9	33,2	36,7
FXE+	Ref. FAN-DECK			SWP/STD.1/10, SWN/STD.1/10		SWP/STD.1/10, SWN/STD.1/10									
	Peso netto	2 Tubi/Pipe	Kg	11,5	12,0	15,0	15,8	Non disponibile		Non disponibile		Non disponibile		Non disponibile	
	Net weight	4 Tubi/Pipe	Kg	12,4	12,9	16,0	16,8	Not available		Not available		Not available		Not available	

DN(\*) = Diametro nominale, F = Attacchi idraulici batteria Gas femmina

DN(\*) = Nominal diameter, F = Female gas water coil connections

• Peso netto= solo unità, escluso imballo

• Net weight= unit only, excluding packaging

## Versione incasso verticale (aspirazione e mandata aria frontali; senza mobile) Vertical concealed version (front air intake and supply; without cabinet)

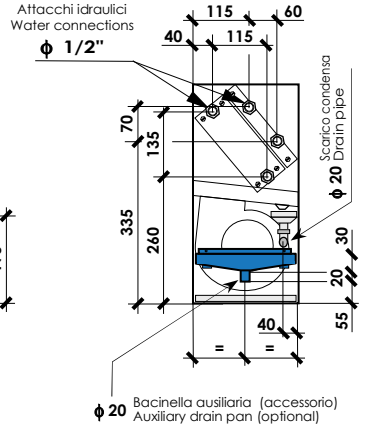
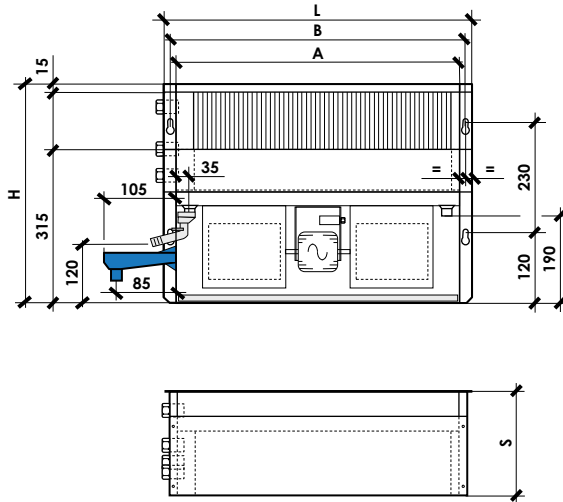
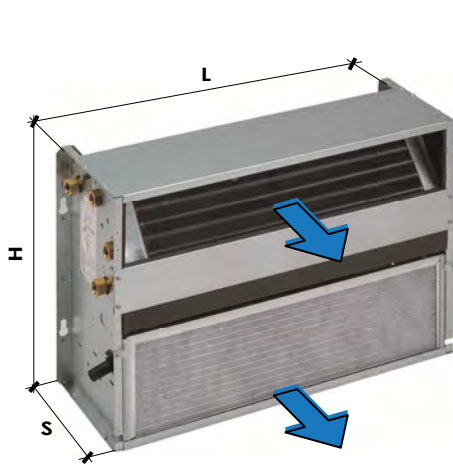

Taglia - Size			DF-X, FXE, ...	100	200	300	400	500	600	700	800	900	1000	1100	1200
Dimensioni principali Main dimensions	L	mm		450	450	650	650	850	850	1050	1050	1250	1250	1450	1450
	H	mm		450	450	450	450	450	450	450	450	450	450	450	450
	S	mm		215	215	215	215	215	215	215	215	215	215	215	215
	A	mm		400	400	600	600	800	800	1.000	1.000	1.200	1.200	1.400	1.400
	B	mm		425	425	625	625	825	825	1.025	1.025	1.225	1.225	1.425	1.425
N° Motori				1	1	1	1	1	1	1	1	1	1	1	1
N° Ventilatori				1	1	1	1	2	2	2	2	2	2	3	3
Batteria caldo/freddo Heating/cooling coil	Contenuto acqua Water volume (l)			0,69	0,70	0,99	1,01	1,30	1,31	1,60	1,62	1,91	1,92	2,21	2,23
	Ranghi - Rows DN(*)			3R 1/2" F	3R 1/2" F	3R 1/2" F	3R 1/2" F	3R 1/2" F	3R 1/2" F	3R 1/2" F	3R 1/2" F	3R 1/2" F	3R 1/2" F	3R 1/2" F	3R 1/2" F
Batteria caldo Heating coil	Contenuto acqua Water volume (l)			0,23	0,23	0,33	0,33	0,43	0,43	0,54	0,54	0,64	0,64	0,74	0,74
	Ranghi - Rows DN(*)			1R 1/2" F	1R 1/2" F	1R 1/2" F	1R 1/2" F	1R 1/2" F	1R 1/2" F	1R 1/2" F	1R 1/2" F	1R 1/2" F	1R 1/2" F	1R 1/2" F	1R 1/2" F
Scarico condensa - Drain pipe			φ(mm)	20	20	20	20	20	20	20	20	20	20	20	20
FX	Ref. FAN-DECK			C2, A40.6V, [P2-3-5],[N1-2-4]		C3.15, A40.6V, [P2-3-5],[N1-2-4]		C3.15, A80.6V, [P2-3-5],[N1-2-4]		C5, A80.6V, [P2-3-5],[N1-2-4]		C3.15, A80.6V, [P2-3-5],[N1-2-4]		C3.15, 5V, [P2-3-4],[ND.1-3-4]	
	Peso netto	2 Tubi/Pipe	Kg	11,0	11,5	14,0	14,8	20,2	21,2	23,7	25,2	27,8	29,3	30,8	34,3
	Net weight	4 Tubi/Pipe	Kg	11,9	12,4	15,0	15,8	21,3	22,3	24,9	26,4	29,1	30,6	32,2	35,7
FX-P	Ref. FAN-DECK			C3.15, A40.6V, [P2-3-5],[N1-2-4]		C3.15, A80.6V, [P2-3-5],[N1-2-4]		C2, A80.6V, [P2-3-5],[N1-2-4]		C4, A80.6V, [P2-3-5],[N1-2-4]		C4, 6V, [P2-3-4],[N1-3-5]		C4, 5V, [P2-3-4],[N1-3-4]	
	Peso netto	2 Tubi/Pipe	Kg	11,6	12,1	14,8	15,6	20,7	21,7	24,6	26,1	28,9	30,4	31,9	35,4
	Net weight	4 Tubi/Pipe	Kg	12,5	13,0	15,8	16,6	21,8	22,8	25,8	27,3	30,2	31,7	33,3	36,8
FX-S	Ref. FAN-DECK			C1.5, A40.6V, [P4-5-6],[N4-5-6]		C2.5, A40.6V, [P4-5-6],[N4-5-6]		C2.5, A80.6V, [P4-5-6],[N4-5-6]		C4, A80.6V, [P4-5-6],[N4-5-6]		C2.5, A80.6V, [P4-5-6],[N4-5-6]		C4, V3-A240, [P4-5-6],[N4-5-6]	
	Peso netto	2 Tubi/Pipe	Kg	11,7	12,2	14,7	15,5	20,9	21,9	24,4	25,9	28,5	30,0	31,5	35,0
	Net weight	4 Tubi/Pipe	Kg	12,6	13,1	15,7	16,5	22,0	23,0	25,6	27,1	29,8	31,3	31,9	36,4
FXE	Ref. FAN-DECK			SWP/STD.1/10, SWN/STD.1/10		SWP/STD.1/10, SWN/STD.1/10		SWP/STD.1/10, SWN/Pot1.D.1/10		SWP/STD.1/10, SWN/Pot1.D.1/10		SWP/STD.1/10, SWN/Pot1.1/10		SWP/RFX.1/10, SWD/RFXD.1/10	
	Peso netto	2 Tubi/Pipe	Kg	10,6	11,1	14,1	14,9	20,6	21,6	23,6	25,1	26,9	28,4	30,6	34,1
	Net weight	4 Tubi/Pipe	Kg	11,5	12,0	15,1	15,9	21,7	22,7	24,8	26,3	28,2	29,7	32,0	35,5
FXE-P	Ref. FAN-DECK			SWP/STD.1/10, SWD/STD.1/10		SWP/STD.1/10, SWD/STD.1/10		SWP/Pot1.1/10, SWD/Pot1.1/10		SWP/Pot1.1/10, SWD/Pot1.1/10		SWP/RFX.1/10, SWD/RFX.1/10		SWP/RFX.1/10, SWD/RFXD.1/10	
	Peso netto	2 Tubi/Pipe	Kg	10,9	11,4	14,4	15,2	20,9	21,9	23,9	25,4	27,2	28,7	30,9	34,4
	Net weight	4 Tubi/Pipe	Kg	11,8	12,3	15,4	16,2	22,0	23,0	25,1	26,6	28,5	30,0	32,3	35,8
FXE-S	Ref. FAN-DECK			SWP/STD.1/7, SWD/STD.1/7		SWP/STD.1/7, SWD/STD.1/7		SWP/STD.1/7, SWD/STD.1/7		SWP/STD.1/8, SWD/STD.1/8		SWP/STD.1/9, SWD/STD.1/9		SWP/RFX.1/10, SWD/RFXD.2.1/10	
	Peso netto	2 Tubi/Pipe	Kg	11,6	12,1	15,1	15,9	21,6	22,6	24,6	26,1	27,9	29,4	31,6	35,1
	Net weight	4 Tubi/Pipe	Kg	12,5	13,0	16,1	16,9	22,7	23,7	25,8	27,3	29,2	30,7	33,0	36,5
FXE+	Ref. FAN-DECK			SWP/STD.1/10, SWN/STD.1/10		SWP/STD.1/10, SWN/STD.1/10									
	Peso netto	2 Tubi/Pipe	Kg	11,4	11,9	14,9	15,7	Non disponibile Not available		Non disponibile Not available		Non disponibile Not available		Non disponibile Not available	
	Net weight	4 Tubi/Pipe	Kg	12,3	12,8	15,8	16,6								

DN(\*) = Diametro nominale, F = Attacchi idraulici batteria Gas femmina

DN(\*) = Nominal diameter, F = Female gas water coil connections

• Peso netto= solo unità, escluso imballo

• Net weight= unit only, excluding packaging

## Versione Incasso orizzontale (base; senza mobile) Horizontal concealed version (basic; without cabinet)

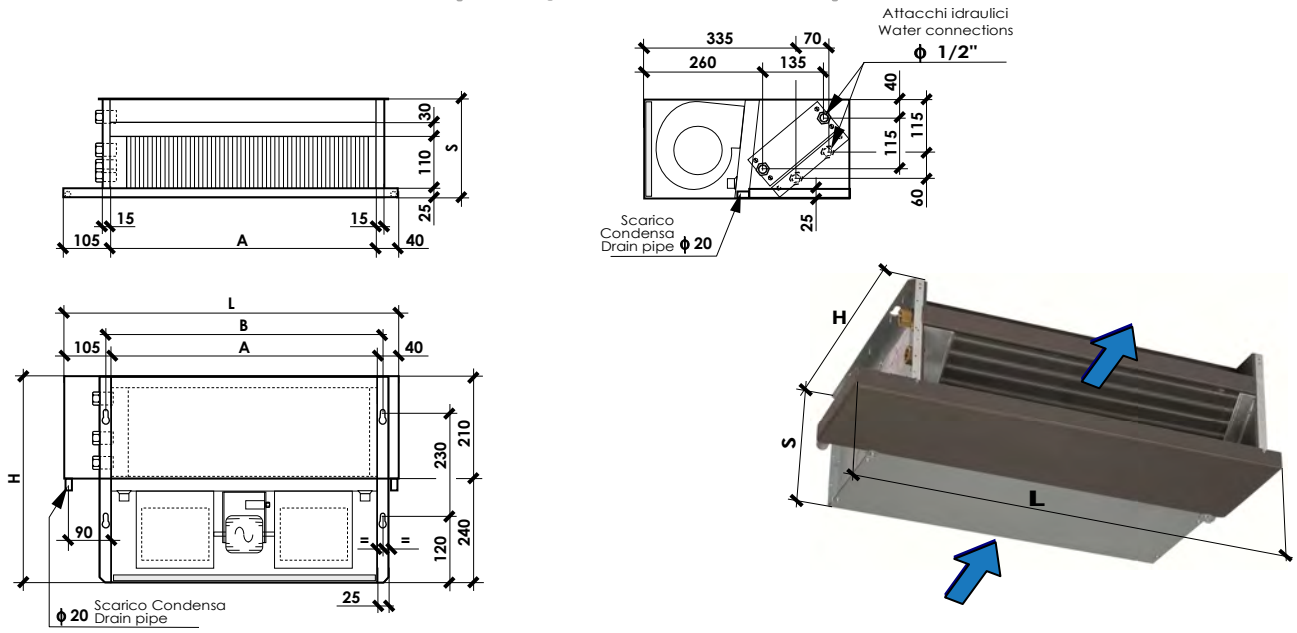

Taglia - Size			DF-X, FXE, ...	100	200	300	400	500	600	700	800	900	1000	1100	1200
Dimensioni principali Main dimensions	L	mm		545	545	745	745	945	945	1145	1145	1345	1345	1545	1545
	H	mm		450	450	450	450	450	450	450	450	450	450	450	450
	S	mm		215	215	215	215	215	215	215	215	215	215	215	215
	A	mm		400	400	600	600	800	800	1.000	1.000	1.200	1.200	1.400	1.400
	B	mm		425	425	625	625	825	825	1.025	1.025	1.225	1.225	1.425	1.425
N° Motori				1	1	1	1	1	1	1	1	1	1	1	1
N° Ventilatori				1	1	1	1	2	2	2	2	2	2	3	3
Batteria caldo/freddo Heating/cooling coil	Contenuto acqua Water volume (l)			0,69	0,70	0,99	1,01	1,30	1,31	1,60	1,62	1,91	1,92	2,21	2,23
	Ranghi - Rows DN(*)			3R 1/2" F	3R 1/2" F	3R 1/2" F	3R 1/2" F	3R 1/2" F	3R 1/2" F	3R 1/2" F	3R 1/2" F	3R 1/2" F	3R 1/2" F	3R 1/2" F	3R 1/2" F
Batteria caldo Heating coil	Contenuto acqua Water volume (l)			0,23	0,23	0,33	0,33	0,43	0,43	0,54	0,54	0,64	0,64	0,74	0,74
	Ranghi - Rows DN(*)			1R 1/2" F	1R 1/2" F	1R 1/2" F	1R 1/2" F	1R 1/2" F	1R 1/2" F	1R 1/2" F	1R 1/2" F	1R 1/2" F	1R 1/2" F	1R 1/2" F	1R 1/2" F
Scarico condensa - Drain pipe			φ(mm)	20	20	20	20	20	20	20	20	20	20	20	20
FX	Ref. FAN-DECK			C2, A40.6V, [P2-3-5],[N1-2-4]		C3.15, A40.6V, [P2-3-5],[N1-2-4]		C3.15, A80.6V, [P2-3-5],[N1-2-4]		C5, A80.6V, [P2-3-5],[N1-2-4]		C3.15, A80.6V, [P2-3-5],[N1-2-4]		C3.15, 5V, [P2-3-4],[ND1-3-4]	
	Peso netto	2 Tubi/Pipe	Kg	11,1	11,6	13,9	14,7	19,9	20,9	23,3	24,8	27,2	28,7	30,0	33,5
	Net weight	4 Tubi/Pipe	Kg	12,0	12,5	14,9	15,7	21,0	22,0	24,5	26,0	28,5	30,0	31,4	34,9
FX-P	Ref. FAN-DECK			C3.15, A40.6V, [P2-3-5],[N1-2-4]		C3.15, A80.6V, [P2-3-5],[N1-2-4]		C2, A80.6V, [P2-3-5],[N1-2-4]		C4, A80.6V, [P2-3-5],[N1-2-4]		C4, 6V, [P2-3-4],[N1-3-5]		C4, 5V, [P2-3-4],[N1-3-4]	
	Peso netto	2 Tubi/Pipe	Kg	11,7	12,2	14,7	15,5	20,4	21,4	24,2	25,7	28,3	29,8	31,1	34,6
	Net weight	4 Tubi/Pipe	Kg	12,6	13,1	15,7	16,5	21,5	22,5	25,4	26,9	29,6	31,1	32,5	36,0
FX-S	Ref. FAN-DECK			C1.5, A40.6V, [P4-5-6],[N4-5-6]		C2.5, A40.6V, [P4-5-6],[N4-5-6]		C2.5, A80.6V, [P4-5-6],[N4-5-6]		C4, A80.6V, [P4-5-6],[N4-5-6]		C2.5, A80.6V, [P4-5-6],[N4-5-6]		C4, V3-A240, [P4-5-6],[N4-5-6]	
	Peso netto	2 Tubi/Pipe	Kg	11,8	12,3	14,6	15,4	20,6	21,6	24,0	25,5	27,9	29,4	30,7	34,2
	Net weight	4 Tubi/Pipe	Kg	12,7	13,2	15,6	16,4	21,7	22,7	25,2	26,7	29,2	30,7	32,1	35,6
FXE	Ref. FAN-DECK			SWP/STD.1/10, SWN/STD.1/10		SWP/STD.1/10, SWN/STD.1/10		SWP/STD.1/10, SWN/PoH1.D.1/10		SWP/STD.1/10, SWN/PoH1.D.1/10		SWP/STD.1/10, SWN/PoH1.1/10		SWP/RFX.1/10, SWD/RFXD.1/10	
	Peso netto	2 Tubi/Pipe	Kg	10,7	11,2	14,0	14,8	20,3	21,3	23,2	24,7	26,3	27,8	29,8	33,3
	Net weight	4 Tubi/Pipe	Kg	11,6	12,1	15,0	15,8	21,4	22,4	24,4	25,9	27,6	29,1	31,2	34,7
FXE-P	Ref. FAN-DECK			SWP/STD.1/10, SWD/STD.1/10		SWP/STD.1/10, SWD/STD.1/10		SWP/PoH1.1/10, SWD/PoH1.1/10		SWP/PoH1.1/10, SWD/PoH1.1/10		SWP/RFX.1/10, SWD/RFX.1/10		SWP/RFX.1/10, SWD/RFXD.1/10	
	Peso netto	2 Tubi/Pipe	Kg	11,0	11,5	14,3	15,1	20,6	21,6	23,5	25,0	26,6	28,1	30,1	33,6
	Net weight	4 Tubi/Pipe	Kg	11,9	12,4	15,3	16,1	21,7	22,7	24,7	26,2	27,9	29,4	31,5	35,0
FXE-S	Ref. FAN-DECK			SWP/STD.1/7, SWD/STD.1/7		SWP/STD.1/7, SWD/STD.1/7		SWP/STD.1/7, SWD/STD.1/7		SWP/STD.1/8, SWD/STD.1/8		SWP/STD.1/9, SWD/STD.1/9		SWP/RFX.1/10, SWD/RFXD.1/10	
	Peso netto	2 Tubi/Pipe	Kg	11,7	12,2	15,0	15,8	21,3	22,3	24,2	25,7	27,3	28,8	30,8	34,3
	Net weight	4 Tubi/Pipe	Kg	12,6	13,1	16,0	16,8	22,4	23,4	25,4	26,9	28,6	30,1	32,2	35,7
FXE+	Ref. FAN-DECK			SWP/STD.1/10, SWN/STD.1/10		SWP/STD.1/10, SWN/STD.1/10		Non disponibile		Non disponibile		Non disponibile		Non disponibile	
	Peso netto	2 Tubi/Pipe	Kg	11,5	12,0	14,8	15,6	Not available		Not available		Not available		Not available	
	Net weight	4 Tubi/Pipe	Kg	12,4	12,9	15,8	16,6	Not available		Not available		Not available		Not available	

DN(\*) = Diametro nominale, F = Attacchi idraulici batteria Gas femmina

DN(\*) = Nominal diameter, F = Female gas water coil connections

• Peso netto= solo unità, escluso imballo

• Net weight= unit only, excluding packaging

## Versione incasso orizzontale (aspirazione aria frontale; senza mobile) Horizontal concealed version (front air intake; without cabinet)

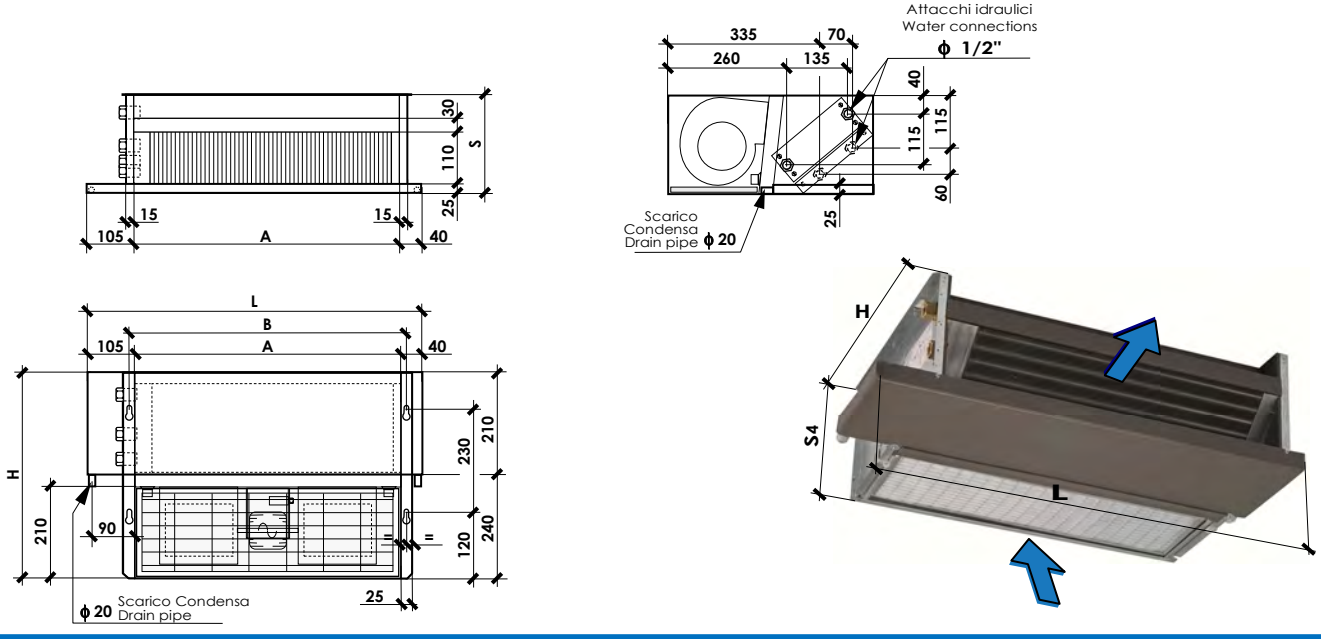

Taglia - Size		DF-X, FXE, ...	100	200	300	400	500	600	700	800	900	1000	1100	1200
Dimensioni principali Main dimensions	L	mm	545	545	745	745	945	945	1145	1145	1345	1345	1545	1545
	H	mm	450	450	450	450	450	450	450	450	450	450	450	450
	S	mm	215	215	215	215	215	215	215	215	215	215	215	215
	A	mm	400	400	600	600	800	800	1.000	1.000	1.200	1.200	1.400	1.400
	B	mm	425	425	625	625	825	825	1.025	1.025	1.225	1.225	1.425	1.425
N° Motori N° Ventilatori			1	1	1	1	1	1	1	1	1	1	1	1
Batteria caldo/freddo Heating/cooling coil	Contenuto acqua Water volume (l)		0,69	0,70	0,99	1,01	1,30	1,31	1,60	1,62	1,91	1,92	2,21	2,23
	Ranghi - Rows DN(*)		3R 1/2" F	3R 1/2" F	3R 1/2" F	3R 1/2" F	3R 1/2" F	3R 1/2" F	3R 1/2" F	3R 1/2" F	3R 1/2" F	3R 1/2" F	3R 1/2" F	3R 1/2" F
Batteria caldo Heating coil	Contenuto acqua Water volume (l)		0,23	0,23	0,33	0,33	0,43	0,43	0,54	0,54	0,64	0,64	0,74	0,74
	Ranghi - Rows DN(*)		1R 1/2" F	1R 1/2" F	1R 1/2" F	1R 1/2" F	1R 1/2" F	1R 1/2" F	1R 1/2" F	1R 1/2" F	1R 1/2" F	1R 1/2" F	1R 1/2" F	1R 1/2" F
Scarico condensa - Drain pipe		φ(mm)	20	20	20	20	20	20	20	20	20	20	20	20
FX	Ref. FAN-DECK		C2, A40.6V, [P2-3-5],[N1-2-4]		C3.15, A40.6V, [P2-3-5],[N1-2-4]		C3.15, A80.6V, [P2-3-5],[N1-2-4]		C5, A80.6V, [P2-3-5],[N1-2-4]		C3.15, A80.6V, [P2-3-5],[N1-2-4]		C3.15, 5V, [P2-3-4],[ND1-3-4]	
	Peso netto	2 Tubi/Pipe	Kg	11,0	11,5	13,8	14,6	19,8	20,8	23,1	24,6	27,0	28,5	29,8
	Net weight	4 Tubi/Pipe	Kg	11,9	12,4	14,8	15,6	20,9	21,9	24,3	25,8	28,3	29,8	31,2
FX-P	Ref. FAN-DECK		C3.15, A40.6V, [P2-3-5],[N1-2-4]		C3.15, A80.6V, [P2-3-5],[N1-2-4]		C2, A80.6V, [P2-3-5],[N1-2-4]		C4, A80.6V, [P2-3-5],[N1-2-4]		C4, 6V, [P2-3-4],[N1-3-5]		C4, 5V, [P2-3-4],[N1-3-4]	
	Peso netto	2 Tubi/Pipe	Kg	11,6	12,1	14,6	15,4	20,3	21,3	24,0	25,5	28,1	29,6	30,9
	Net weight	4 Tubi/Pipe	Kg	12,5	13,0	15,6	16,4	21,4	22,4	25,2	26,7	29,4	30,9	32,3
FX-S	Ref. FAN-DECK		C1.5, A40.6V, [P4-5-6],[N4-5-6]		C2.5, A40.6V, [P4-5-6],[N4-5-6]		C2.5, A80.6V, [P4-5-6],[N4-5-6]		C4, A80.6V, [P4-5-6],[N4-5-6]		C2.5, A80.6V, [P4-5-6],[N4-5-6]		C4, V3-A240, [P4-5-6],[N4-5-6]	
	Peso netto	2 Tubi/Pipe	Kg	11,7	12,2	14,5	15,3	20,5	21,5	23,8	25,3	27,7	29,2	30,5
	Net weight	4 Tubi/Pipe	Kg	12,6	13,1	15,5	16,3	21,6	22,6	25,0	26,5	29,0	30,5	31,9
FXE	Ref. FAN-DECK		SWP/STD.1/10, SWN/STD.1/10		SWP/STD.1/10, SWN/STD.1/10		SWP/STD.1/10, SWN/Pot1.D.1/10		SWP/STD.1/10, SWN/Pot1.D.1/10		SWP/STD.1/10, SWN/Pot1.1/10		SWP/RFX.1/10, SWD/RXD1.1/10	
	Peso netto	2 Tubi/Pipe	Kg	10,6	11,1	13,9	14,7	20,2	21,2	23,0	24,5	26,1	27,6	29,6
	Net weight	4 Tubi/Pipe	Kg	11,5	12,0	14,9	15,7	21,3	22,3	24,2	25,7	27,4	28,9	31,0
FXE-P	Ref. FAN-DECK		SWP/STD.1/10, SWD/STD.1/10		SWP/STD.1/10, SWD/STD.1/10		SWP/Pot1.1/10, SWD/Pot1.1/10		SWP/Pot1.1/10, SWD/Pot1.1/10		SWP/RFX.1/10, SWD/RFX.1/10		SWP/RFX.1/10, SWD/RXD1.1/10	
	Peso netto	2 Tubi/Pipe	Kg	10,9	11,4	14,2	15,0	20,5	21,5	23,3	24,8	26,4	27,9	29,9
	Net weight	4 Tubi/Pipe	Kg	11,8	12,3	15,2	16,0	21,6	22,6	24,5	26,0	27,7	29,2	31,3
FXE-S	Ref. FAN-DECK		SWP/STD.1/7, SWD/STD.1/7		SWP/STD.1/7, SWD/STD.1/7		SWP/STD.1/7, SWD/STD.1/7		SWP/STD.1/8, SWD/STD.1/8		SWP/STD.1/9, SWD/STD.1/9		SWP/RFX.1/10, SWD/RXD2.1/10	
	Peso netto	2 Tubi/Pipe	Kg	11,6	12,1	14,9	15,7	21,2	22,2	24,0	25,5	27,1	28,6	30,6
	Net weight	4 Tubi/Pipe	Kg	12,5	13,0	15,9	16,7	22,3	23,3	25,2	26,7	28,4	29,9	32,0
FXE+	Ref. FAN-DECK		SWP/STD.1/10, SWN/STD.1/10		SWP/STD.1/10, SWN/STD.1/10		Non disponibile		Non disponibile		Non disponibile		Non disponibile	
	Peso netto	2 Tubi/Pipe	Kg	11,4	11,9	14,7	15,5	Not available		Not available		Not available		
	Net weight	4 Tubi/Pipe	Kg	12,3	12,8	15,7	16,5	Not available		Not available		Not available		

DN(\*) = Diametro nominale, F = Attacchi idraulici batteria Gas femmina

DN(\*) = Nominal diameter, F = Female gas water coil connections

• Peso netto= solo unità, escluso imballo

• Net weight= unit only, excluding packaging

## Versione incasso orizzontale (base; senza mobile) – Estrazione filtro dal basso Horizontal concealed version (basic; without cabinet) – Downward filter extraction

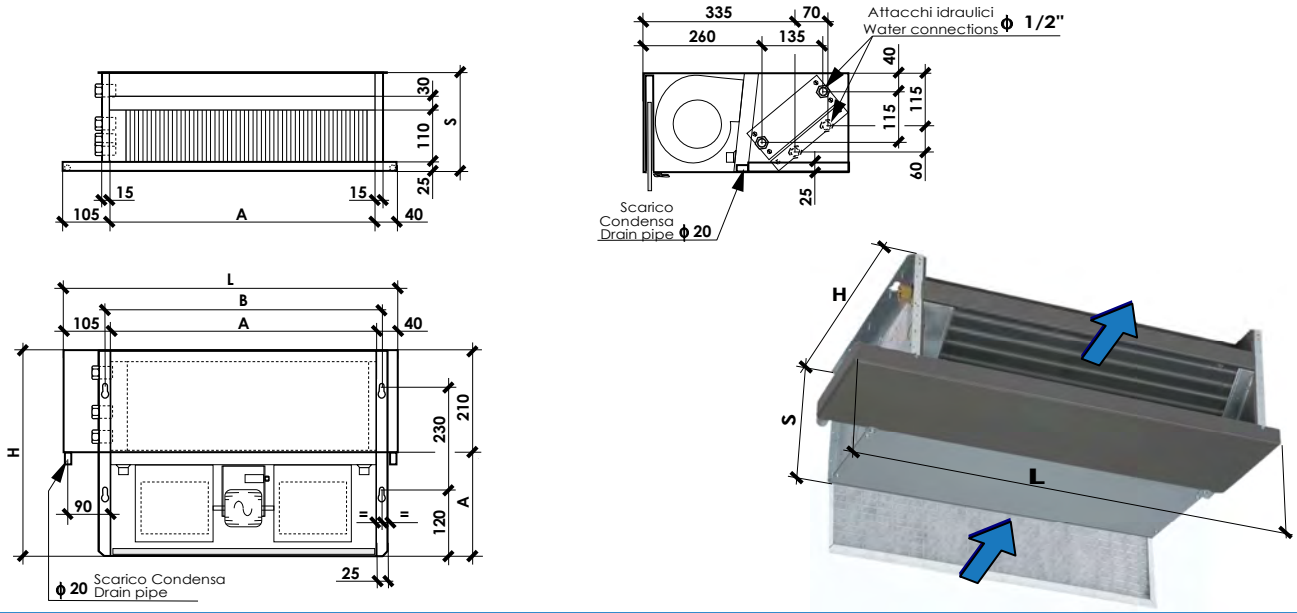

Taglia - Size		DF-X, FXE, ...	100	200	300	400	500	600	700	800	900	1000	1100	1200	
Dimensioni principali Main dimensions	L	mm	545	545	745	745	945	945	1145	1145	1345	1345	1545	1545	
	H	mm	450	450	450	450	450	450	450	450	450	450	450	450	
	S	mm	215	215	215	215	215	215	215	215	215	215	215	215	
	A	mm	400	400	600	600	800	800	1.000	1.000	1.200	1.200	1.400	1.400	
	B	mm	425	425	625	625	825	825	1.025	1.025	1.225	1.225	1.425	1.425	
N° Motori N° Ventilatori			1	1	1	1	1	1	1	1	1	1	1	1	
Batteria caldo/freddo Heating/cooling coil	Contenuto acqua Water volume (l)		0,69	0,70	0,99	1,01	1,30	1,31	1,60	1,62	1,91	1,92	2,21	2,23	
	Ranghi - Rows DN(*)		3R 1/2" F	3R 1/2" F	3R 1/2" F	3R 1/2" F	3R 1/2" F	3R 1/2" F	3R 1/2" F	3R 1/2" F	3R 1/2" F	3R 1/2" F	3R 1/2" F	3R 1/2" F	
Batteria caldo Heating coil	Contenuto acqua Water volume (l)		0,23	0,23	0,33	0,33	0,43	0,43	0,54	0,54	0,64	0,64	0,74	0,74	
	Ranghi - Rows DN(*)		1R 1/2" F	1R 1/2" F	1R 1/2" F	1R 1/2" F	1R 1/2" F	1R 1/2" F	1R 1/2" F	1R 1/2" F	1R 1/2" F	1R 1/2" F	1R 1/2" F	1R 1/2" F	
Scarico condensa - Drain pipe		Ø(mm)	20	20	20	20	20	20	20	20	20	20	20	20	
FX	Ref. FAN-DECK		C2, A40.6V, [P2-3-5],[N1-2-4]		C3.15, A40.6V, [P2-3-5],[N1-2-4]		C3.15, A80.6V, [P2-3-5],[N1-2-4]		C5, A80.6V, [P2-3-5],[N1-2-4]		C3.15, A80.6V, [P2-3-5],[N1-2-4]		C3.15, 5V, [P2-3-4],[ND.1-3-4]		
	Peso netto	2 Tubi/Pipe	Kg	11,2	11,7	14,0	14,8	20,0	21,0	23,4	24,9	27,3	28,8	30,1	33,6
	Net weight	4 Tubi/Pipe	Kg	12,1	12,6	15,0	15,8	21,1	22,1	24,6	26,1	28,6	30,1	31,5	35,0
FX-P	Ref. FAN-DECK		C3.15, A40.6V, [P2-3-5],[N1-2-4]		C3.15, A80.6V, [P2-3-5],[N1-2-4]		C2, A80.6V, [P2-3-5],[N1-2-4]		C4, A80.6V, [P2-3-5],[N1-2-4]		C4, 6V, [P2-3-4],[N1-3-5]		C4, 5V, [P2-3-4],[N1-3-4]		
	Peso netto	2 Tubi/Pipe	Kg	11,8	12,3	14,8	15,6	20,5	21,5	24,3	25,8	28,4	29,9	31,2	34,7
	Net weight	4 Tubi/Pipe	Kg	12,7	13,2	15,8	16,6	21,6	22,6	25,5	27,0	29,7	31,2	32,4	36,1
FX-S	Ref. FAN-DECK		C1.5, A40.6V, [P4-5-6],[N4-5-6]		C2.5, A40.6V, [P4-5-6],[N4-5-6]		C2.5, A80.6V, [P4-5-6],[N4-5-6]		C4, A80.6V, [P4-5-6],[N4-5-6]		C2.5, A80.6V, [P4-5-6],[N4-5-6]		C4, V3-A240, [P4-5-6],[N4-5-6]		
	Peso netto	2 Tubi/Pipe	Kg	11,9	12,4	14,7	15,5	20,7	21,7	24,1	25,6	28,0	29,5	30,8	34,3
	Net weight	4 Tubi/Pipe	Kg	12,8	13,3	15,7	16,5	21,8	22,8	25,3	26,8	29,3	30,8	32,2	35,7
FXE	Ref. FAN-DECK		SWP/STD.1/10, SWN/STD.1/10		SWP/STD.1/10, SWN/STD.1/10		SWP/STD.1/10, SWN/Pot.1/10		SWP/STD.1/10, SWN/Pot.1/10		SWP/STD.1/10, SWN/Pot.1/10		SWP/RFX.1/10, SWD/RXD.1/10		
	Peso netto	2 Tubi/Pipe	Kg	10,8	11,3	14,1	14,9	20,4	21,4	23,3	24,8	26,4	27,9	29,9	33,4
	Net weight	4 Tubi/Pipe	Kg	11,7	12,2	15,1	15,9	21,5	22,5	24,5	26,0	27,7	29,2	31,3	34,8
FXE-P	Ref. FAN-DECK		SWP/STD.1/10, SWD/STD.1/10		SWP/STD.1/10, SWD/STD.1/10		SWP/Pot.1/10, SWD/Pot.1/10		SWP/Pot.1/10, SWD/Pot.1/10		SWP/RFX.1/10, SWD/RFX.1/10		SWP/RFX.1/10, SWD/RFX.1/10		
	Peso netto	2 Tubi/Pipe	Kg	11,1	11,6	14,4	15,2	20,7	21,7	23,6	25,1	26,7	28,2	30,2	33,7
	Net weight	4 Tubi/Pipe	Kg	12,0	12,5	15,4	16,2	21,8	22,8	24,8	26,3	28,0	29,5	31,6	35,1
FXE-S	Ref. FAN-DECK		SWP/STD.1/7, SWD/STD.1/7		SWP/STD.1/7, SWD/STD.1/7		SWP/STD.1/7, SWD/STD.1/7		SWP/STD.1/8, SWD/STD.1/8		SWP/STD.1/9, SWD/STD.1/9		SWP/RFX.1/10, SWD/RXD.2/1/10		
	Peso netto	2 Tubi/Pipe	Kg	11,8	12,3	15,1	15,9	21,4	22,4	24,3	25,8	27,4	28,9	30,9	34,4
	Net weight	4 Tubi/Pipe	Kg	12,7	13,2	16,1	16,9	22,5	23,5	25,5	27,0	28,7	30,2	32,3	35,8
FXE+	Ref. FAN-DECK		SWP/STD.1/10, SWN/STD.1/10		SWP/STD.1/10, SWN/STD.1/10		Non disponibile		Non disponibile		Non disponibile		Non disponibile		
	Peso netto	2 Tubi/Pipe	Kg	11,6	12,1	14,9	15,7	Not available		Not available		Not available			
	Net weight	4 Tubi/Pipe	Kg	12,5	13,0	15,9	16,7	Not available		Not available		Not available			

DN(\*) = Diametro nominale, F = Attacchi idraulici batteria Gas femmina

DN(\*) = Nominal diameter, F = Female gas water coil connections

• Peso netto= solo unità, escluso imballo

• Net weight= unit only, excluding packaging

## Versione incasso orizzontale (base; senza mobile) – Estrazione filtro dall'alto Horizontal concealed version (basic; without cabinet) – Upward filter extraction

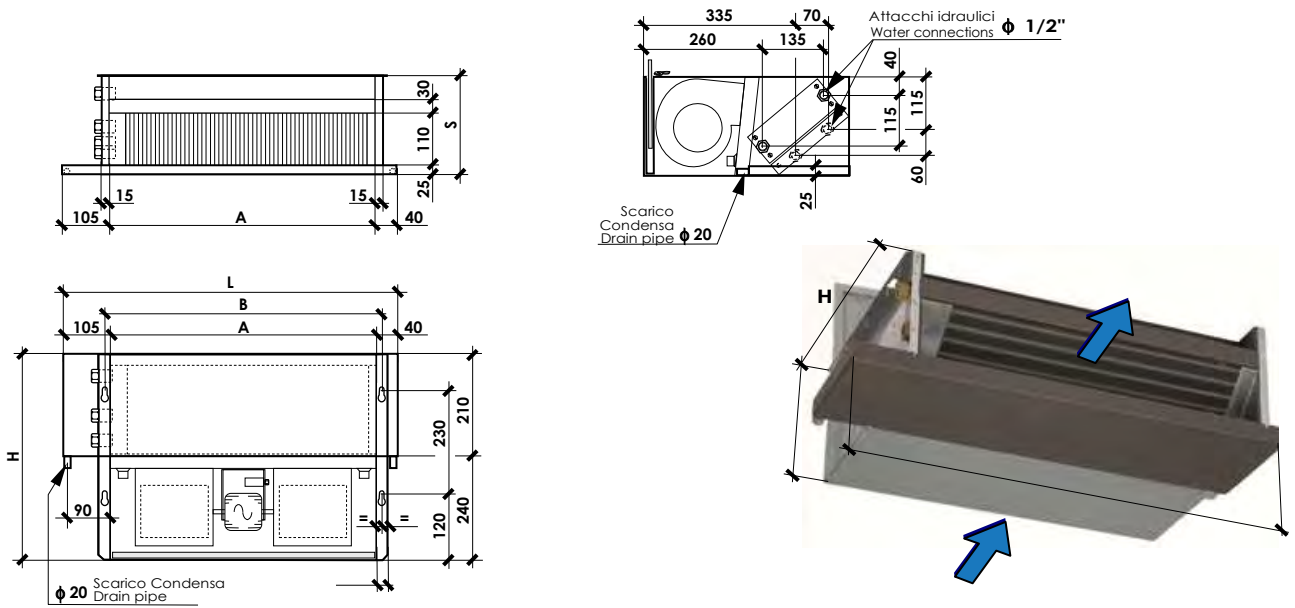

Taglia - Size		DF-X, FXE, ...	100	200	300	400	500	600	700	800	900	1000	1100	1200	
Dimensioni principali Main dimensions	L	mm	545	545	745	745	945	945	1145	1145	1345	1345	1545	1545	
	H	mm	450	450	450	450	450	450	450	450	450	450	450	450	
	S	mm	215	215	215	215	215	215	215	215	215	215	215	215	
	A	mm	400	400	600	600	800	800	1.000	1.000	1.200	1.200	1.400	1.400	
	B	mm	425	425	625	625	825	825	1.025	1.025	1.225	1.225	1.425	1.425	
N° Motori			1	1	1	1	1	1	1	1	1	1	1	1	
N° Ventilatori			1	1	1	1	2	2	2	2	2	2	3	3	
Batteria caldo/freddo Heating/cooling coil	Contenuto acqua Water volume (l)		0,69	0,70	0,99	1,01	1,30	1,31	1,60	1,62	1,91	1,92	2,21	2,23	
	Ranghi - Rows DN(*)		3R 1/2" F	3R 1/2" F	3R 1/2" F	3R 1/2" F	3R 1/2" F	3R 1/2" F	3R 1/2" F	3R 1/2" F	3R 1/2" F	3R 1/2" F	3R 1/2" F	3R 1/2" F	
Batteria caldo Heating coil	Contenuto acqua Water volume (l)		0,23	0,23	0,33	0,33	0,43	0,43	0,54	0,54	0,64	0,64	0,74	0,74	
	Ranghi - Rows DN(*)		1R 1/2" F	1R 1/2" F	1R 1/2" F	1R 1/2" F	1R 1/2" F	1R 1/2" F	1R 1/2" F	1R 1/2" F	1R 1/2" F	1R 1/2" F	1R 1/2" F	1R 1/2" F	
Scarico condensa - Drain pipe		φ(mm)	20	20	20	20	20	20	20	20	20	20	20	20	
FX	Ref. FAN-DECK		C2, A40.6V, [P2-3-5],[N1-2-4]		C3.15, A40.6V, [P2-3-5],[N1-2-4]		C3.15, A80.6V, [P2-3-5],[N1-2-4]		C5, A80.6V, [P2-3-5],[N1-2-4]		C3.15, A80.6V, [P2-3-5],[N1-2-4]		C3.15, 5V, [P2-3-4],[ND.1-3-4]		
	Peso netto	2 Tubi/Pipe	Kg	11,2	11,7	14,0	14,8	20,0	21,0	23,4	24,9	27,3	28,8	30,1	33,6
	Net weight	4 Tubi/Pipe	Kg	12,1	12,6	15,0	15,8	21,1	22,1	24,6	26,1	28,6	30,1	31,5	35,0
FX-P	Ref. FAN-DECK		C3.15, A40.6V, [P2-3-5],[N1-2-4]		C3.15, A80.6V, [P2-3-5],[N1-2-4]		C2, A80.6V, [P2-3-5],[N1-2-4]		C4, A80.6V, [P2-3-5],[N1-2-4]		C4, 6V, [P2-3-4],[N1-3-5]		C4, 5V, [P2-3-4],[N1-3-4]		
	Peso netto	2 Tubi/Pipe	Kg	11,8	12,3	14,8	15,6	20,5	21,5	24,3	25,8	28,4	29,9	31,2	34,7
	Net weight	4 Tubi/Pipe	Kg	12,7	13,2	15,8	16,6	21,6	22,6	25,5	27,0	29,7	31,2	32,4	36,1
FX-S	Ref. FAN-DECK		C1.5, A40.6V, [P4-5-6],[N4-5-6]		C2.5, A40.6V, [P4-5-6],[N4-5-6]		C2.5, A80.6V, [P4-5-6],[N4-5-6]		C4, A80.6V, [P4-5-6],[N4-5-6]		C2.5, A80.6V, [P4-5-6],[N4-5-6]		C4, V3-A240, [P4-5-6],[N4-5-6]		
	Peso netto	2 Tubi/Pipe	Kg	11,9	12,4	14,7	15,5	20,7	21,7	24,1	25,6	28,0	29,5	30,8	34,3
	Net weight	4 Tubi/Pipe	Kg	12,8	13,3	15,7	16,5	21,8	22,8	25,3	26,8	29,3	30,8	32,2	35,7
FXE	Ref. FAN-DECK		SWP/STD.1/10, SWN/STD.1/10		SWP/STD.1/10, SWN/STD.1/10		SWP/STD.1/10, SWN/Pot1.D.1/10		SWP/STD.1/10, SWN/Pot1.D.1/10		SWP/STD.1/10, SWN/Pot1.1/10		SWP/STD.1/10, SWD/RXD.1/10		
	Peso netto	2 Tubi/Pipe	Kg	10,8	11,3	14,1	14,9	20,4	21,4	23,3	24,8	26,4	27,9	29,9	33,4
	Net weight	4 Tubi/Pipe	Kg	11,7	12,2	15,1	15,9	21,5	22,5	24,5	26,0	27,7	29,2	31,3	34,8
FXE-P	Ref. FAN-DECK		SWP/STD.1/10, SWD/STD.1/10		SWP/STD.1/10, SWD/STD.1/10		SWP/Pot1.1/10, SWD/Pot1.1/10		SWP/Pot1.1/10, SWD/Pot1.1/10		SWP/FIX.1/10, SWD/FIX.1/10		SWP/FIX.1/10, SWD/FIXD.1/10		
	Peso netto	2 Tubi/Pipe	Kg	11,1	11,6	14,4	15,2	20,7	21,7	23,6	25,1	26,7	28,2	30,2	33,7
	Net weight	4 Tubi/Pipe	Kg	12,0	12,5	15,4	16,2	21,8	22,8	24,8	26,3	28,0	29,5	31,6	35,1
FXE-S	Ref. FAN-DECK		SWP/STD.1/7, SWD/STD.1/7		SWP/STD.1/7, SWD/STD.1/7		SWP/STD.1/7, SWD/STD.1/7		SWP/STD.1/8, SWD/STD.1/8		SWP/STD.1/9, SWD/STD.1/9		SWP/FIX.1/10, SWD/FIXD.2.1/10		
	Peso netto	2 Tubi/Pipe	Kg	11,8	12,3	15,1	15,9	21,4	22,4	24,3	25,8	27,4	28,9	30,9	34,4
	Net weight	4 Tubi/Pipe	Kg	12,7	13,2	16,1	16,9	22,5	23,5	25,5	27,0	28,7	30,2	32,3	35,8
FXE+	Ref. FAN-DECK		SWP/STD.1/10, SWN/STD.1/10		SWP/STD.1/10, SWN/STD.1/10		Non disponibile		Non disponibile		Non disponibile		Non disponibile		
	Peso netto	2 Tubi/Pipe	Kg	11,6	12,1	14,9	15,7	Not available		Not available		Not available			
	Net weight	4 Tubi/Pipe	Kg	12,5	13,0	15,9	16,7	Not available		Not available		Not available			

DN(\*) = Diametro nominale, F = Attacchi idraulici batteria Gas femmina

DN(\*) = Nominal diameter, F = Female gas water coil connections

• Peso netto= solo unità, escluso imballo

• Net weight= unit only, excluding packaging

# Dimatek®

DIMATEK COMFORT SOLUTIONS, S.L.



- EN** WE RESERVE THE RIGHT TO CHANGE ALL OR PART OF THE FEATURES OF THE ARTICLES OR CONTENTS OF THIS DOCUMENT, WITHOUT PRIOR NOTICE
- ES** NOS RESERVAMOS EL DERECHO DE CAMBIAR TOTAL O PARCIALMENTE LAS CARACTERÍSTICAS DE NUESTROS ARTÍCULOS O CONTENIDO DE ESTE DOCUMENTO SIN PREVIO AVISO.
- FR** NOUS NOUS RÉSERVONS LE DROIT DE MODIFIER EN TOUT OU EN PARTIE LES CARACTÉRISTIQUES DE NOS ARTICLES OU LE CONTENU DE CE DOCUMENT SANS AVIS
- DE** DE WIR BEHALTEN UNS DAS RECHT VOR, DIE CHARAKTERISTIKA UNSERER PRODUKTE ODER DEN INHALT DIESES DOKUMENTS OHNE VORHERIGE ANKÜNDIGUNG VOLLSTÄNDIG ODER TEILWEISE ZU ÄNDERN.
- IT** CI RISERVIAMO IL DIRITTO DI MODIFICARE IN TUTTO O IN PARTE LE CARATTERISTICHE DEI NOSTRI ARTICOLI O CONTENUTO DI QUESTO DOCUMENTO SENZA PREAVVISO.
- NE** WIJ BEHOUDEN ONS HET RECHT VOOR OM DE KENMERKEN VAN DE ARTIKELS OF DE INHOUD VAN DIT DOCUMENT ZONDER VOORAF GAANDE KENNISGEVING GEHEEL OF GEDEELTELIJK TE WIJZIGEN.
- PO** RESERVAMO-NOS O DIREITO DE ALTERAR TOTAL OU PARCIALMENTE AS CARACTERÍSTICAS DOS NOSSOS ARTIGOS OU O CONTEÚDO DESTE DOCUMENTO SEM AVISO PRÉVIO.