

Air quality
Enjoy a pure environment



Airkcool[®]

Efficiency Air Conditioning Spain

Customized Air Handling Systems

Catálogo Unidades Terminales FCU
Terminal Units Catalogue FCU



Dimatek[®]
DIMATEK COMFORT SOLUTIONS, S.L.



© Dimatek&Airkcool 2024 ALL RIGHTS RESERVED. PROPRIETARY DOCUMENT

HydroSystem

Air quality
Enjoy the silence



2024



DF XE

Fan coil units
Ventilconvettori

Dimatek®

DIMATEK COMFORT SOLUTIONS, S.L.

GUIA PRODUCTO

PRODUCT GUIDE

2024



Sistemi

Idronici

Modelo/Versions

DF-XE/FH

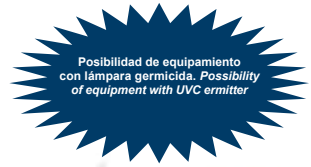

* Consultar pag 65
*Posibilidad de equipamiento con lámpara germicida o Ionizador de plasma frío
*Possibility of equip-ment with UVC - emitter plasma ionize

Características generales

Fan-coils idóneos para los sistemas de aire acondicionado en hoteles, oficinas, hospitales, escuelas, etc. La gran flexibilidad de prestaciones, una gran eficacia del confort ambiental y la autonomía de funcionamiento de cada unidad, son las ventajas más destacadas en estos equipos. Estas unidades terminales incorporan las más modernas innovaciones tecnológicas, obteniendo una posición de liderazgo y prestigio en el mercado. El bajo nivel sonoro, la higienización (filtración de aire), un eficaz intercambio térmico (obtenido con la entrada de aire externo o en combinación con sistemas centralizados de tratamiento de aire primario), la elección de los componentes y el diseño de montaje mecánico, es una garantía de calidad y eficiencia del producto. Disponible con lámparas germicidas de alta eficiencia. Estas lámparas no sólo evitan el riesgo de contaminación, sino que también permiten altos ahorros de energía (aproximadamente un 15%). Así mismo se mantiene constantemente limpia la batería.

Modelo horizontal con envoltorio (DF-XE/FM)

Para instalaciones en techo, modelos de ejecución horizontal. La versión "DF-XE/FM" se puede instalar con su parte posterior contra la pared con la toma de aire de la aspiración en la parte inferior. El filtro es rígido lavable y es fácilmente desprendible. La rejilla está construida en plástico de ABS de gran resistencia, color gris claro RAL 7047. Carcasa de acero galvanizado con pintura epoxy al horno a 180°C. El color estándar es RAL 9010 y a petición de cualquier solicitud se puede pintar del RAL que se solicite. El aluminio y las rejillas pintadas están también disponibles en otro RAL.

Baterías Construidas con tubos de cobre de alta eficacia a partir de 9.52 mm (3/8"), escalonado para un mayor traspaso térmico. Las aletas son del aluminio de alta calidad y eficacia y se enlazan sobre los tubos. Éstos incorporan conexiones hembra - macho con purgadores incluidos en cada batería. Las baterías están disponibles para la instalaciones 3R (10T) de serie o 2R, para instalaciones a 4 tubos 2R+1 o 3R+1, siendo también posible ejecuciones especiales con doble batería y baterías de 4R. Las unidades estándar siempre tienen las conexiones de batería a la derecha vistas de frente. Disponibles conexiones de lados izquierdos. Es posible invertir la dirección de los colectores efectuando una sencilla maniobra de cambio de batería. La presión de funcionamiento máxima es 28 bar, con una temperatura máxima de trabajo de 120°C. Serie U : 4R e 3R+1 (6T)

Envoltorio de la unidad construida con un moderno y elegante diseño a partir de 1,2 mm en chapa galvanizada de alta calidad. El acabado es de poliéster en polvo epoxy al horno a 180°C y se aplica un espesor mínimo de 80 micras en ambos lados. El color estándar es blanco puro (RAL 9010). A petición del cliente se pueden pintar en cualquier color RAL. La carcasa esta sujeta en la parte inferior con dos tornillos colocados debajo de la rejilla de descarga. El espacio en la parte posterior permite colocar una batería de agua para instalaciones a 4T, la bandeja de condensados y las conexiones eléctricas. La carcasa se quita fácilmente para inspección y mantenimiento. La rejilla de descarga incorpora aletas articuladas, que permiten el acceso a los controles. La rejilla estándar está fabricada de plástico ABS gris claro (RAL 7047) y el flujo de aire es frontal pudiéndose invertir la desviación del aire. También pueden suministrarse las rejillas pintadas sobre el aluminio anodizado.

Bandeja de condensados en chapa galvanizada de acero con pintura epoxy acabado en ambos lados. La bandeja de condensados de las unidades horizontales esta totalmente aislada con espuma ignífuga de 5 mm con una resistencia al fuego clase '1' std Europeo. En unidades verticales, el aislamiento sólo cubre la zona donde se recopilan los condensados en la bandeja, que está inclinada. Se puede aplicar opcionalmente un aislamiento completo. También opcionalmente son posibles varios tipos de aislamiento alternativos y bandejas de drenaje de acero inoxidable.

Grupo ventilador con ventiladores centrífugos de doble aspiración de bajos niveles sonoros construidos con acero galvanizado. Turbinas de ABS de muy bajos niveles sonoros equilibradas estática y dinámicamente. Tamaños 01, 02 y 03 utilizan un grupo ventilador monobloc. El grupo ventilador es fácilmente desmontable para su inspección y mantenimiento montado sobre soporte con dos tornillos.

Motores Monofásicos de 4 polos con condensador permanentemente conectado (PSC/AOM). Seis velocidades disponibles de ventilador de las cuales 3 son conectables a un conmutador de velocidad o termostato. IP40 clase "B" con protección térmica incorporada V230, 1/50-60 Hz . Montados sobre soportes elásticos antivibrantes.

Filtro de aire en fibra sintética lavable clase E2-G2-M1 incorporado en marco metálico galvanizado. Fácilmente extraíble para su limpieza y mantenimiento. Opcionalmente filtros planos o de alta eficacia.

Termostatos con muchas posibilidades estándares para diversos controles de los equipos: a bulbo, para instalaciones a 2/4 tubos, electrónicos, digitales. Montaje en los equipos o disponibles para instalación exterior. Consultar diferentes opciones en el apartado Termostatos y control.

Motor ECI (opcional) acoplado a un motor inverter y gestionado con un regulador especial. La tecnología aplicada permite un ahorro de energía extremadamente baja con una modulación continua del caudal de aire, acoplándose así mismo a las funciones reales y energéticas del ambiente.

Modelos FM con certificación Eurovent

General information

Ideally suited for use in air conditioning systems for hotels, offices, hospitals, schools and many more. The wide range of heating and cooling capacities, the efficient control of room conditions, and the independent user control offered by single room units are the major advantages available. With their unique characteristics and benefits, they are in a leading position in the market for environmental control. Their special features are quietness, cleanliness of filtered air and fresh air makeup either directly from outside or by a central air conditioning system. These benefits provide a guarantee of quality and product rationality in design, efficiency and use.

Horizontal Cased Unit.
For installation where floor space is at a premium and where units can be ceiling mounted. Can be installed with its back against a wall, the air intake being on the underside. The washable filter is clipped to the return grill and is easily removable. The standard supply and return air grilles are manufactured from ABS plastic, colour RAL 7047 clear grey. The cabinet is realised with heavy metal galvanized steel epoxy painted and baked at 180°C. Standard colour RAL 9010 and on request any RAL colour at Architect demand can be realised. Painted grilles are also available.

FM/FM-EC Vertical exposed unit with bottom return and upper supply. Supporting feet The unit must be kept elevated from the floor to allow air to enter. A10F accessory painted feet are required if the unit is not hanged on the wall. FMO/FMO-EC Horizontal exposed unit with bottom (rear on demand) return and frontal supply.

- appartamenti extralusso, ville di prestigio, uffici direzionali, ecc.)
- Per applicazioni dove la silenziosità è un dovere (es. sale registrazioni, sale radiofoniche, teatri, laboratori, biblioteche, sale di studio, case di cura, ecc.)
- Per applicazioni "per sé", quando ci si vuol fare un regalo
- Motore elettrico AC, asincrono monofase a gabbia di scoiattolo, provvisto di protettore termico TH (Klixon), condensatore di marcia sempre inserito, 4 poli, IP42, Classe B, doppio isolamento, 230Vac-1Ph-50/60Hz.
- Motore monovelocità + Autotrasformatore a 6 uscite/velocità ben equipaziate (con prestazioni da max=100% a min=40-50%). Autotrasformatore installato all'esterno della spalla dell'unità, per facilitare eventuali operazioni di manutenzione e sostituzione. Questa tecnologia garantisce una enorme flessibilità del prodotto, lasciando all'utente la possibilità di connettere in cantiere qualsiasi velocità selezionabile fra le 6 disponibili, a seconda delle necessità. Su richiesta (senza sovrapprezzo) cablaggio di qualsiasi tema di velocità desiderata.
- Motore silenziato, Condensatore ridotto, Rimodulazione velocità su range ridotto (precablaggio in azienda delle 3 velocità V4,5,6, con 1=Max e 6=Min)
- Isolamento termoacustico & antivibrante rinforzato (interno, sull'intera unità)
- Attento collaudo con equilibratura grado 4 + range accettabilità vibrazioni e rumore ridotto

- flats, extra-luxury villas, executive offices, etc.)
- For installations where silence is a must (e.g. recording rooms, radio rooms, theatres, laboratories, libraries, nursing homes, etc.)
- For "ourselves" installation, when we want to make ourselves a gift
- AC electric motor, asynchronous single-phase squirrel cage, provided with heat protection TH (Klixon), running capacitor permanently switched on, 4 poles, IP42, Class B, double insulation, 230Vac-1Ph-50/60Hz.
- Single-speed motor + Autotransformer with 6 equi-spaced outputs/speed (with performances from max=100% to min=40-50%). Autotransformer is installed externally, on the unit side, to enable easy maintenance operations.
- This technology guarantees big flexibility, with possible connections according to the specific end-user needs, higher or lower speeds selectable upon 6 available.
- On request (no extra cost), different speed can be connected.
- Silenced motor, Reduced condenser, Re-modulated speed on a reduced range (pre-wired at the factory of 3 different speed V4,5,6, where 1=Max e 6=Min)
- Thermal-acoustic & antivibration insulation reinforced (internal, on the whole unit)
- Careful testing with 4th balancing degree + reduced vibration and noise acceptance range

Serie FXE 

Fandeck con Motore elettronico EC-Brushless + Inverter

Motore tecnologia BLAC (Brushless Alternating Current) a magneti permanenti, senza spazzole, sensor less, 2 protettori (TP-termico/Klixon + EP-elettronico/SW), IP40, Classe B, doppio isolamento, 230Vac-1Ph-50/60Hz.

Motore HEE (High Energy Efficiency motor) ad elevato risparmio energetico (oltre il 50%) e conseguente riduzione CO2 (amico dell'ambiente).

Regolazione modulante con segnale 0...10Vdc tramite i nostri comandi o tramite sistemi di regolazione indipendenti (del cliente): La modulazione 0-100% della portata aria (e conseguentemente della potenza termica e frigorifera), permette di adeguare le prestazioni, istante per istante, alle effettive esigenze del locale da climatizzare, garantendo Comfort totale e riduzione della rumorosità.

Inverter con Dip-switch per settare diversi tipi di Firmware di controllo del motore + Dip-switch per rimodulare il campo di lavoro su un nuovo range più limitato (da 0...10Vdc a 0...6,5Vdc) + Contatto pulito di allarme.

Fan-deck with EC-Brushless electronic motor + Inverter

BLAC Technology (Brushless Alternating Current) motor, with permanent magnets, brush less, sensor less, 2 protections (TP-thermal/Klixon + EP-electronic/SW), IP40, Class B, double insulation, 230Vac-1Ph-50/60Hz.

HEE motor (High Energy Efficiency motor) with high efficiency (over 50%) and consequent CO2 reduction (environment friendly).

Modulating regulation with 0...10Vdc signal with our control panel or with independent regulation system (by client): The modulation 0-100% of the air flow (and consequently of the heating and cooling capacity), allows to adapt the performances, instant to instant, to the actual needs of the room to be conditioned, warranting total comfort and noise level reduction.

Inverter with Dip-switches to set different types of motor's control firmware + Dip-switches to re-modulate the working field on new limited range (up 0...10Vdc to 0...6,5Vdc) + Alarm dry contact.

Serie FXE-P 

Motore elettronico EC-Brushless, rinforzato, Inverter settato con FW-HP (firmware curva Qa-ESP ad alta prevalenza e maggiore RPM), con Contatto pulito di allarme

Motore tecnologia BLAC (Brushless Alternating Current) a magneti permanenti, senza spazzole, sensor less, 2 protettori (TP-termico/Klixon + EP-elettronico/SW), IP40, Classe B, doppio isolamento, 230Vac-1Ph-50/60Hz.

Motore HEE (High Energy Efficiency motor) ad elevato risparmio energetico (oltre il 50%) e conseguente riduzione CO2 (amico dell'ambiente).

Regolazione modulante con segnale 0...10Vdc tramite i nostri comandi o tramite sistemi di regolazione indipendenti (del cliente): La modulazione 0-100% della portata aria (e conseguentemente della potenza termica e frigorifera), permette di adeguare le prestazioni, istante per istante, alle effettive esigenze del locale da climatizzare, garantendo Comfort totale e riduzione della rumorosità.

Reinforced EC-Brushless electronic motor, Inverter setting with FW-HP (firmware Qa-ESP curve with high static pressure and higher RPM), with Alarm dry contact

BLAC Technology (Brushless Alternating Current) motor, with permanent magnets, brush less, sensor less, 2 protections (TP-thermal/Klixon + EP-electronic/SW), IP40, Class B, double insulation, 230Vac-1Ph-50/60Hz.

HEE motor (High Energy Efficiency motor) with high efficiency (over 50%) and consequent CO2 reduction (environment friendly).

Modulating regulation with 0...10Vdc signal with our control panel or with independent regulation system (by client): The modulation 0-100% of the air flow (and consequently of the heating and cooling capacity), allows to adapt the performances, instant to instant, to the actual needs of the room to be conditioned, warranting total comfort and noise level reduction.

Serie FXE-S 

I Supersilenziosi EC: Prodotto dedicato a tutti quei clienti che vogliono godersi la climatizzazione senza rinunciare ad un ineguagliabile comfort acustico

Prodotto appositamente progettato con obiettivo "Minimizzare Livello Sonoro":

- Per applicazioni dove la silenziosità è un valore (es. camere da letto, Hotel 5stelle, appartamenti extralusso, ville di prestigio, uffici direzionali, ecc.)
- Per applicazioni dove la silenziosità è un dovere (es. sale registrazioni, sale radiofoniche, teatri, laboratori, biblioteche, sale di studio, case di cura, ecc.)
- Per applicazioni "per sé", quando ci si vuol fare un regalo

Motore elettronico EC-Brushless, Tecnologia BLAC (Brushless Alternating Current) a magneti permanenti, senza spazzole, sensor less, 2 protettori (TP-termico/Klixon + EP-elettronico/SW), IP40, Classe B, doppio isolamento, 230Vac-1Ph-50/60Hz.

Motore HEE (High Energy Efficiency motor) ad elevato risparmio energetico (oltre il 50%) e conseguente riduzione CO2 (amico dell'ambiente).

Regolazione modulante con segnale 0...10Vdc tramite i nostri comandi o tramite sistemi di regolazione indipendenti (del cliente): La modulazione 0-100% della portata aria (e conseguentemente della potenza termica e frigorifera), permette di adeguare le prestazioni, istante per istante, alle effettive esigenze del locale da climatizzare, garantendo Comfort totale e riduzione della rumorosità.

Inverter con Dip-switch per settare diversi tipi di Firmware di controllo del motore + Dip-switch per rimodulare il campo di lavoro su diversi range di segnale (da 0...10Vdc a 0...6,5Vdc) + Contatto pulito di allarme.

- Motore silenziato, Inverter settato con FW-SIL (firmware con RPM controllata) e Rimodulazione segnale su range ridotto
- Isolamento termoacustico & antivibrante rinforzato (interno, sull'intera unità)
- Attento collaudo con equilibratura grado 4 + range accettabilità vibrazioni e rumore ridotto

The Super-silent EC: Product dedicated to all the customers that want to enjoy air conditioning without sacrificing an incomparable acoustic comfort

Product specially designed with the target to "Minimize the Sound Level":

- For installations where silence is a value (e.g. bedrooms, 5 Stars Hotels, extra-luxury flats, extra-luxury villas, executive offices, etc.)
- For installations where silence is a must (e.g. recording rooms, radio rooms, theatres, laboratories, libraries, nursing homes, etc.)
- For "ourselves" installation, when we want to make ourselves a gift

EC-Brushless electronic motor, BLAC Technology (Brushless Alternating Current), with permanent magnets, brush less, sensor less, 2 protections (TP-thermal/Klixon + EP-electronic/SW), IP40, Class B, double insulation, 230Vac-1Ph-50/60Hz.

HEE motor (High Energy Efficiency motor) with high efficiency (over 50%) and consequent CO2 reduction (environment friendly).

Modulating regulation with 0...10Vdc signal with our control panel or with independent regulation system (by client): The modulation 0-100% of the air flow (and consequently of the heating and cooling capacity), allows to adapt the performances, instant to instant, to the actual needs of the room to be conditioned, warranting total comfort and noise level reduction.

Inverter with Dip-switches to set different types of motor's control firmware + Dip-switches to re-modulate the working field on different limited range (up 0...10Vdc to 0...6,5Vdc) + Alarm dry contact.

- Silenced motor, Inverter set with FW-SIL (firmware with controlled RPM) and re-modulated signal on reduced range
- Thermal-acoustic & antivibration insulation reinforced (internal, on the whole unit)
- Careful testing with 4th balancing degree + reduced vibration and noise acceptance range

Serie FXE+ 

ALTISSIMA EFFICIENZA, ECOSOSTENIBILE, PRESTAZIONI INEGUAGLIABILI, TOP DI GAMMA, Motore elettronico EC-BRUSHLESS PLUS con AXI-Tecnology

Risultato di un progetto internazionale finalizzato a ricerche Ecosostenibili, trova sintesi in un motore con Statore e Rotore a Dischi affiancati (sohili, con magneti permanenti e bobine di eccitazione affiancate) calettati nella mezzera del ventilatore, eliminando qualsiasi ostruzione e deviazione alle linee di flusso aria e riducendo drasticamente qualsiasi possibilità di vibrazione/rumore.

Risultato eccezionale ed ineguagliabile: rispetto ad un EC classico, oltre ad un incredibile risparmio energetico, a parità di RPM (e dunque a parità di rumore)

VERY HIGH EFFICIENCY, ECO-SUSTAINABLE, INCOMPARABLE PERFORMANCES, TOP OF RANGE, EC-BRUSHLESS PLUS electronic motor with AXI-Tecnology

Result of an international project aimed to eco-sustainable research, its synthesised in a motor with side by side Stator and Rotor discs (slim, with permanent magnets and facing excitation coils) keyed in the fan centre line, eliminating any obstruction and deviation to the air flow lines and drastically reducing any possible vibration/noise.

Extraordinary and incomparable result: compared to a classic EC, in addition to an incredible energy saving, at same RPM (and therefore at same noise level), it guarantees a higher airflow and static pressure (+20%), vice-versa at same air flow and

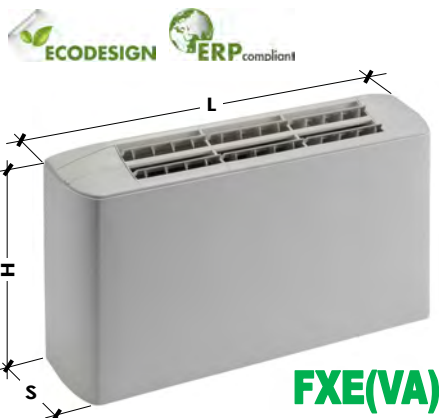

FXE(VA)

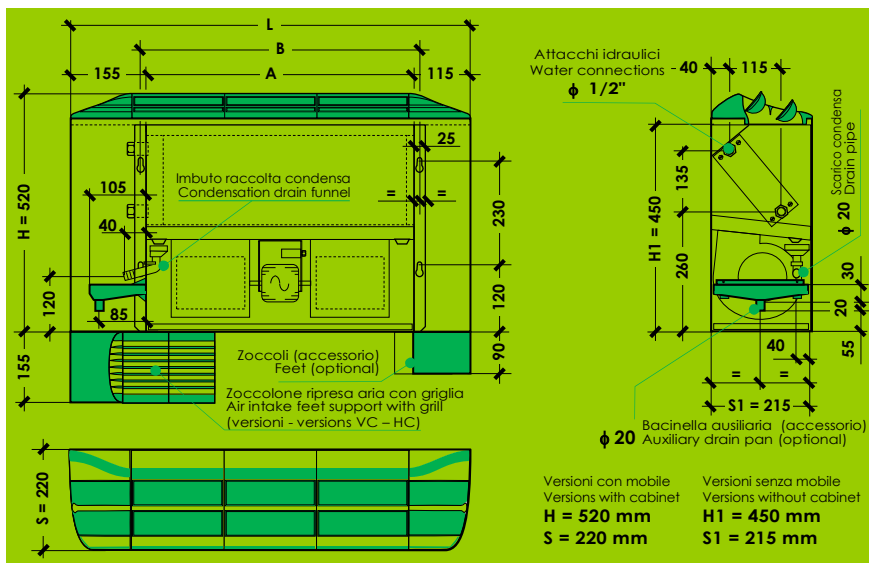

Versioni con mobile
Versions with cabinet
H = 520 mm
S = 220 mm

Versioni senza mobile
Versions without cabinet
H1 = 450 mm
S1 = 215 mm

Taglia - Size	DF-XE	130	230	330	430	530	630	730	830	930	1030	1130	1230
Potenz. Frigorifera Totale - Total (1) W		1.550	2.070	2.600	3.090	4.010	4.540	5.690	6.610	7.680	9.190	9.280	10.360
Cooling capacity Sensibile - Sensible (1) W		1.340	1.680	2.130	2.370	3.100	3.490	4.490	4.970	5.800	6.770	7.350	8.050
Potenzialità Termica - Heating capacity (2) W		3.880	5.080	6.140	6.870	8.760	10.120	12.400	13.720	15.820	18.470	20.370	22.400
Portata aria nominale - Nominal Air flow (3) m³/h		390	420	520	570	745	800	1.050	1.100	1.320	1.350	1.810	1.840
Portata acqua Raffred. - Cooling l/h		267	356	447	531	690	781	979	1.137	1.321	1.581	1.596	1.782
Water flow (4) Riscald. - Heating l/h		334	437	528	591	753	870	1.066	1.180	1.361	1.588	1.752	1.926
Perdite di carico acqua Raffred. - Cooling kPa		14,0	17,5	19,5	21,7	25,8	27,5	26,0	28,7	29,9	30,3	29,0	31,3
Water pressure drops (5) Riscald. - Heating kPa		17,1	20,5	21,1	20,9	24,1	26,7	24,1	24,1	24,8	23,8	27,2	28,5
Livelli sonori - Sound levels (6) Min-Med-Max dB(A)		13-25-38	13-27-40	15-31-44	16-33-46	16-27-39	16-28-40	16-35-45	17-36-46	14-36-49	15-37-50	16-39-50	18-39-50
Ref. FAN-DECK		SWP/STD.1/10, SWN/STD.1/10		SWP/STD.1/10, SWN/STD.1/10		SWP/STD.1/10, SWN/PotID.1/10		SWP/STD.1/10, SWN/PotID.1/10		SWP/STD.1/10, SWN/Pot1.1/10		SWP/FIX.1/10, SWD/FIXD.1/10	
Motori/Ventilatori - Motors/Fans No./No.		1/1		1/1		1/2		1/2		1/2		1/3	
Assorb. elettrico nominale (Targa) MAX(7) W		55W		65W		85W		90W		90W		180W	
Nominal current input (Label) MAX(7) A		0,35A		0,45A		0,55A		0,55A		0,55A		1,40A	
Alimentazione elettrica - Power supply													
Batteria caldo/freddo Contenuto acqua - Water volume (l)		0,69	0,70	0,99	1,01	1,30	1,31	1,60	1,62	1,91	1,92	2,21	2,23
Heating/cooling coil [Ranghi], DN(*) - [Rows], DN(*)		[3R], 1/2" F		[3R], 1/2" F		[3R], 1/2" F		[3R], 1/2" F		[3R], 1/2" F		[3R], 1/2" F	
Scarico condensa - Drain pipe ϕ (mm)		20		20		20		20		20		20	
Dimensioni principali Main dimensions	L mm	670		870		1.070		1.270		1.470		1.670	
	H mm	470		470		470		470		470		470	
	S mm	220		220		220		220		220		220	
	A mm	400		600		800		1.000		1.200		1.400	
B mm	425		625		825		1.025		1.225		1.425		
Limite funzionam. inferiore Lower working limit	LFI	1,00	1,00	1,00	1,00	1,00	1,00	1,00	1,00	1,00	1,00	1,00	1,00
	ESP = 0 Pa	Med 0,64	0,64	0,64	0,64	0,67	0,67	0,64	0,64	0,61	0,61	0,63	0,63
(8) 10V-Med-1V = Max-Med-Min RIDUZIONE PORTATA ARIA Coefficienti che definiscono le curve "Portata Aria / Pressione statica" (alle 3 velocità Max-Med-Min) AIR FLOW REDUCTION Coefficients defining the "Air flow / Static pressure" diagrams (at 3 speed Max-Med-Min)	15 Pa	10V 0,94	0,94	0,93	0,93	0,92	0,92	0,92	0,92	0,95	0,95	0,95	0,95
	Med 0,60	0,60	0,60	0,59	0,61	0,61	0,59	0,59	0,57	0,57	0,60	0,60	
	1V 0,27	0,27	0,25	0,25	0,31	0,31	0,26	0,26	0,20	0,20	0,24	0,24	
	30 Pa	10V 0,85	0,85	0,84	0,84	0,81	0,81	0,83	0,83	0,88	0,88	0,90	0,90
	Med 0,55	0,55	0,54	0,54	0,54	0,54	0,53	0,53	0,54	0,54	0,56	0,56	
	1V 0,25	0,25	0,23	0,23	0,27	0,27	0,24	0,23	0,19	0,19	0,23	0,23	
	45 Pa	10V 0,75	0,75	0,74	0,74	0,70	0,70	0,73	0,73	0,82	0,81	0,83	0,83
	Med 0,48	0,48	0,48	0,48	0,47	0,47	0,47	0,47	0,49	0,49	0,52	0,52	
	1V 0,22	0,22	0,20	0,20	0,24	0,23	0,21	0,21	0,18	0,17	0,21	0,21	
	60 Pa	10V 0,61	0,60	0,62	0,62	0,58	0,58	0,62	0,62	0,73	0,73	0,75	0,75
	Med 0,39	0,39	0,39	0,39	0,39	0,39	0,40	0,40	0,44	0,44	0,47	0,47	
	1V \	\	0,17	0,17	0,19	0,20	0,17	0,17	0,16	0,16	0,19	0,19	
75 Pa	10V 0,38	0,38	0,46	0,47	0,43	0,43	0,50	0,50	0,61	0,61	0,65	0,65	
Med 0,25	0,25	0,30	0,30	0,29	0,29	0,32	0,32	0,37	0,37	0,41	0,41		
1V \	\	0,13	0,13	0,15	0,15	0,14	0,14	0,13	0,13	0,16	0,16		
LFS Limite funzionam. superiore Upper working limit	ESP (Pa)	84 Pa	85 Pa	96 Pa	97 Pa	104 Pa	105 Pa	115 Pa	116 Pa	130 Pa	130 Pa	129 Pa	129 Pa
	Qa (x m³/h)	x 0,25	x 0,23	x 0,14	x 0,13	x 0,13	x 0,12	x 0,09	x 0,09	x 0,08	x 0,07	x 0,09	x 0,09
	ESP (Pa)	76 Pa	78 Pa	92 Pa	93 Pa	100 Pa	101 Pa	110 Pa	110 Pa	125 Pa	126 Pa	124 Pa	124 Pa
	Qa (x m³/h)	x 0,23	x 0,22	x 0,14	x 0,13	x 0,12	x 0,12	x 0,09	x 0,09	x 0,07	x 0,07	x 0,09	x 0,09
ESP (Pa)	52 Pa	56 Pa	75 Pa	77 Pa	85 Pa	87 Pa	94 Pa	95 Pa	108 Pa	108 Pa	107 Pa	107 Pa	
Qa (x m³/h)	x 0,2	x 0,19	x 0,13	x 0,12	x 0,12	x 0,11	x 0,08	x 0,08	x 0,07	x 0,07	x 0,08	x 0,08	

(9) RIDUZIONE POTENZIALITÀ FRIGORIFERA/TERMICA (in funzione della riduzione portata aria) COOLING/HEATING CAPACITY REDUCTION (depending on air flow reduction)

Portata aria - Air flow	1,00	0,95	0,90	0,85	0,80	0,75	0,70	0,65	0,60	0,55	0,50	0,45	0,40	0,35	0,30	0,25	0,20	0,15
Potenz. Frigorifera Totale - Total	1,00	0,97	0,95	0,92	0,89	0,87	0,84	0,81	0,77	0,74	0,71	0,67	0,63	0,59	0,55	0,50	0,45	0,39
Cooling capacity Sensibile - Sensible	1,00	0,97	0,93	0,90	0,86	0,83	0,79	0,76	0,72	0,68	0,64	0,60	0,55	0,51	0,46	0,41	0,35	0,29
Potenz. termica - Heating capacity	1,00	0,97	0,94	0,91	0,87	0,84	0,81	0,77	0,74	0,70	0,66	0,62	0,58	0,53	0,49	0,44	0,38	0,32

DN(*) = Diametro nominale, F = Attacchi idraulici batteria Gas femmina

DN(*) = Nominal diameter, F = Female gas water coil connections

Technical data refer to the following conditions: Standard unit - Atmospheric pressure 1013 mbar - Power supply 230Vac/1Ph/50Hz.
 (1) (2) (3) (4) (5): Dati tecnici nominali, portata aria nom. (3) @ Vmax=10V, ESP=0, batteria occlusa. Per le prestazioni: (1) (2) alla portata aria di funzionamento riferita a 8° e 4° al SW, (1) Raffreddamento: Temp. aria 27°C db, 19°C ca, - Temp. acqua ingresso/uscita 7/12°C - Portata aria nominale (3). Per le portate aria di funzionamento (es. alle diverse velocità, Segnali, ESP) vedi (8) e (9); (4) acqua ing. 7°C e portata acqua nominale (4). Raccomandato uso del SW.
 (2) Riscaldamento: Temp. aria 20°C - Temp. acqua ingresso/uscita 70/60°C - Portata aria nominale (3). Per le portate aria di funzionamento (es. alle diverse velocità, Segnali, ESP) vedi (8) e (9); (4) acqua ing. 70°C e portata acqua nominale (4). Raccomandato uso del SW.
 (3) (2) (9) Rete Frigorifera e Termiche: Valori calcolati da SW e dati rilevati in camera climatometrica rif. norme UNI 7940 parte 1°2°, UNI-EN 1397/2001.
 (3) (8) Portata aria e Press. statica: Valori nominali rilevati con cassone rif. norme AMCA210-74 fig.12 e condotto a diametramm. rif. norme CNR-UNI0023.
 (4) Uvelli sonori: Pressione sonora in campo libero, distanza 2 m. Valori calcolati da potenza sonora rilevata in camera riverberante rif. norme ISO 3741 - ISO 3742.
 (7) Dati elettrici: Valori rilevati con Wattmetro Jolegowa W110 (Valore max. nominale, di tarpa motore = valore di riferimento per progettazione impianto elettrico). Per gli assorbimenti elettrici in funzionamento, classi efficienza energetica, ecc. vedi paragrafo "Tab Regolamento UE 2014-2281".
 (8) Sound Levels: Free field sound pressure, 2 m distance. Data calculated based on sound power measured in reverberation room ref. ISO 3741 - ISO 3742 standards.
 (7) Electrical data: Data measured with Wattmeter Jolegowa W110 (Max value, nominal of motor label = reference value for the electrical system design). For the operating electrical power absorption, energy efficiency class, etc. see paragraph "Tab UE 2014-2281 Regulation".

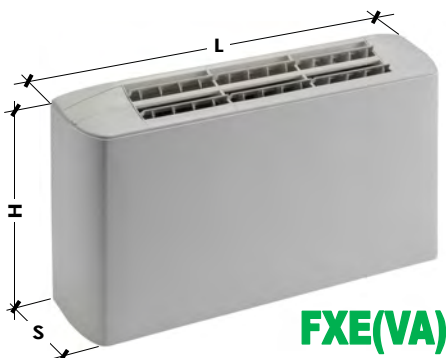

FXE(VA)



Segnale - Signal
0-10V



4
Tubi
Pipe

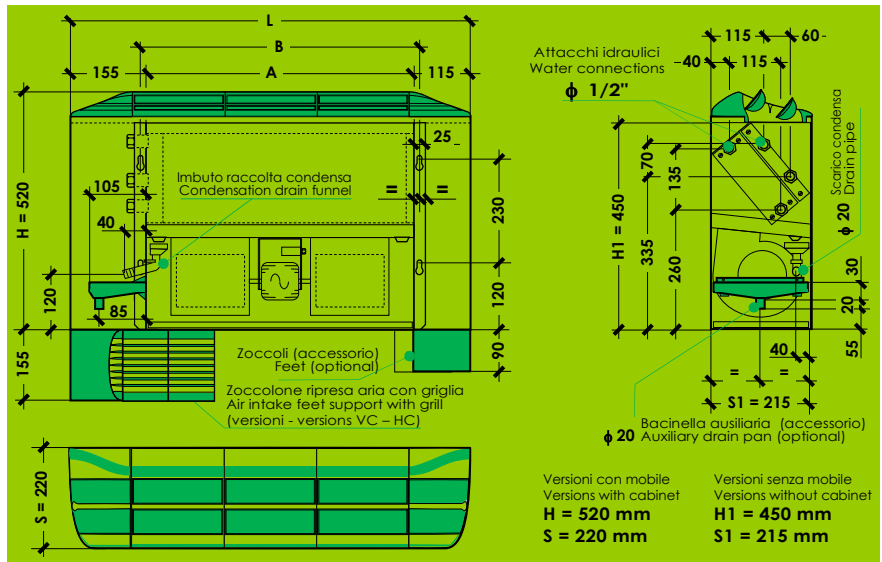

Taglia - Size	DF-XE	131	231	331	431	531	631	731	831	931	1031	1131	1231	
Potenz. Frigorifera Totale - Total (1) W		1.510	2.010	2.540	2.990	3.900	4.390	5.530	6.430	7.500	8.990	9.110	10.180	
Cooling capacity Sensibile - Sensible (1) W		1.300	1.630	2.080	2.290	3.000	3.360	4.340	4.810	5.650	6.590	7.180	7.890	
Potenzialità Termica - Heating capacity (2) W		1.960	2.050	3.270	3.440	4.700	4.880	6.470	6.680	8.170	8.280	10.690	10.830	
Portata aria nominale - Nominal Air flow (3) m ³ /h		370	400	500	540	710	755	1.000	1.050	1.270	1.300	1.750	1.785	
Portata acqua Raffred. - Cooling l/h		260	346	437	514	671	755	951	1.106	1.290	1.546	1.567	1.751	
Water flow (4) Riscald. - Heating l/h		169	176	281	296	404	420	556	574	703	712	919	931	
Perdite di carico acqua Raffred. - Cooling kPa		13,3	16,5	18,6	20,4	24,4	25,7	24,6	27,1	28,5	29,0	27,9	30,1	
Water pressure drops (5) Riscald. - Heating kPa		7,9	8,6	12,3	13,6	24,5	26,4	43,5	46,3	39,4	40,5	45,0	46,2	
Livelli sonori - Sound levels (6) Min-Med-Max dB(A)		13-25-38	13-27-40	15-31-44	16-33-46	16-27-39	16-28-40	16-35-45	17-36-46	14-36-49	15-37-50	16-39-50	18-39-50	
Ref. FAN-DECK		SWP/STD.1/10, SWN/STD.1/10		SWP/STD.1/10, SWN/STD.1/10		SWP/STD.1/10, SWN/PotH.D.1/10		SWP/STD.1/10, SWN/PotH.D.1/10		SWP/STD.1/10, SWN/PotH.D.1/10		SWP/FRX.1/10, SWD/FRXD.1/10		
Motori/Ventilatori - Motors/Fans No./No.		1/1		1/1		1/2		1/2		1/2		1/3		
Assorb. elettrico nominale (Targa) MAX(7) W		55W		65W		85W		90W		90W		180W		
Nominal current input (Label) MAX(7) A		0,35A		0,45A		0,55A		0,55A		0,55A		1,40A		
Alimentazione elettrica - Power supply		230Vac-1Ph-50/60Hz (Signal 0...10Vdc)												
Batteria caldo/freddo Contenuto acqua - Water volume (l)		0,69	0,70	0,99	1,01	1,30	1,31	1,60	1,62	1,91	1,92	2,21	2,23	
Heating/cooling coil [Ranghij], DN(*) - [Rows], DN(*)		[3R], 1/2" F		[3R], 1/2" F		[3R], 1/2" F		[3R], 1/2" F		[3R], 1/2" F		[3R], 1/2" F		
Batteria caldo Contenuto acqua - Water volume (l)		0,23		0,33		0,43		0,54		0,64		0,74		
Heating coil [Ranghij], DN(*) - [Rows], DN(*)		[1R], 1/2" F		[1R], 1/2" F		[1R], 1/2" F		[1R], 1/2" F		[1R], 1/2" F		[1R], 1/2" F		
Scarico condensa - Drain pipe φ (mm)		20		20		20		20		20		20		
Dimensioni principali / Main dimensions	L mm	670		870		1.070		1.270		1.470		1.670		
	H mm	470		470		470		470		470		470		
	S mm	220		220		220		220		220		220		
	A mm	400		600		800		1.000		1.200		1.400		
	B mm	425		625		825		1.025		1.225		1.425		
Limite funzionam. inferiore / Lower working limit	LFI	10V	1,00	1,00	1,00	1,00	1,00	1,00	1,00	1,00	1,00	1,00	1,00	
	ESP = 0 Pa	Med	0,64	0,64	0,64	0,64	0,67	0,67	0,64	0,64	0,61	0,61	0,63	0,63
(8) 10V-Med-1V = Max-Med-Min RIDUZIONE PORTATA ARIA Coefficienti che definiscono le curve "Portata Aria / Pressione statica" (alle 3 velocità Max-Med-Min) AIR FLOW REDUCTION Coefficients defining the "Air flow / Static pressure" diagrams (at 3 speed Max-Med-Min)	15 Pa	10V	0,94	0,94	0,93	0,93	0,92	0,91	0,92	0,92	0,95	0,95	0,95	
		Med	0,60	0,60	0,60	0,60	0,61	0,61	0,59	0,59	0,57	0,57	0,60	0,60
		1V	0,27	0,27	0,25	0,25	0,31	0,31	0,26	0,26	0,20	0,20	0,24	0,24
	30 Pa	10V	0,85	0,85	0,84	0,84	0,81	0,81	0,83	0,83	0,88	0,88	0,90	0,90
		Med	0,55	0,55	0,54	0,54	0,54	0,54	0,53	0,53	0,54	0,54	0,56	0,56
		1V	0,25	0,25	0,23	0,23	0,27	0,27	0,24	0,24	0,19	0,19	0,23	0,23
	45 Pa	10V	0,75	0,75	0,74	0,74	0,70	0,70	0,73	0,73	0,81	0,81	0,83	0,83
		Med	0,48	0,48	0,47	0,48	0,47	0,47	0,47	0,47	0,50	0,49	0,52	0,52
		1V	0,22	0,22	0,20	0,20	0,24	0,23	0,21	0,21	0,17	0,18	0,21	0,21
	60 Pa	10V	0,61	0,61	0,62	0,62	0,58	0,58	0,62	0,62	0,73	0,73	0,75	0,75
		Med	0,39	0,39	0,39	0,39	0,39	0,39	0,40	0,40	0,44	0,44	0,47	0,47
		1V	\	\	0,17	0,17	0,19	0,19	0,17	0,17	0,16	0,16	0,19	0,19
75 Pa	10V	0,39	0,39	0,46	0,46	0,43	0,43	0,50	0,50	0,61	0,61	0,65	0,65	
	Med	0,25	0,25	0,30	0,30	0,29	0,29	0,32	0,32	0,37	0,37	0,41	0,41	
	1V	\	\	0,13	0,13	0,15	0,15	0,14	0,14	0,13	0,13	0,16	0,16	
LFS Limite funzionam. superiore / Upper working limit	ESP (Pa)	10V	83 Pa	84 Pa	96 Pa	97 Pa	104 Pa	104 Pa	115 Pa	115 Pa	130 Pa	130 Pa	129 Pa	129 Pa
	Qa (x m³/h)	Med	x0,26	x0,24	x0,15	x0,14	x0,13	x0,12	x0,10	x0,09	x0,08	x0,08	x0,09	x0,09
		1V	75 Pa	76 Pa	92 Pa	93 Pa	99 Pa	100 Pa	109 Pa	110 Pa	125 Pa	125 Pa	124 Pa	124 Pa
	ESP (Pa)	Med	x0,25	x0,23	x0,14	x0,13	x0,13	x0,12	x0,10	x0,09	x0,08	x0,07	x0,09	x0,09
	ESP (Pa)	1V	50 Pa	53 Pa	75 Pa	76 Pa	83 Pa	86 Pa	93 Pa	93 Pa	106 Pa	106 Pa	107 Pa	107 Pa
	Qa (x m³/h)	Med	x0,20	x0,20	x0,13	x0,12	x0,12	x0,11	x0,09	x0,09	x0,07	x0,07	x0,08	x0,08



**(9) RIDUZIONE POTENZIALITÀ FRIGORIFERA/TERMICA (in funzione della riduzione portata aria)
COOLING/HEATING CAPACITY REDUCTION (depending on air flow reduction)**

Portata aria - Air flow	1,00	0,95	0,90	0,85	0,80	0,75	0,70	0,65	0,60	0,55	0,50	0,45	0,40	0,35	0,30	0,25	0,20	0,15
Potenzialità Frigorifera Totale - Total	1,00	0,97	0,95	0,92	0,89	0,87	0,84	0,81	0,77	0,74	0,71	0,67	0,63	0,59	0,55	0,50	0,45	0,39
Cooling capacity Sensibile - Sensible	1,00	0,97	0,93	0,90	0,86	0,83	0,79	0,76	0,72	0,68	0,64	0,60	0,55	0,51	0,46	0,41	0,35	0,29
Potenzialità termica - Heating capacity	1,00	0,97	0,94	0,91	0,87	0,84	0,81	0,77	0,74	0,70	0,66	0,62	0,58	0,53	0,49	0,44	0,38	0,32

DN(*) = Diametro nominale, F = Attacchi idraulici batteria Gas femmina
Technical data refer to the following conditions: Standard unit - Atmospheric pressure 1013 mbar - Power supply 230Vac/1Ph/50Hz.
 (1) (2) (3) (4) (5) Dati tecnici nominali, rif. portata aria nom. (3) φ Vmax=10V, ESP=0, batteria uscita → Per le prestazioni: (1) (2) alla portata aria di funzionamento riferita a 8H+0 di SW, (3) Raffreddamento: Temp. aria 20°C db, 19°C wb - Temp. acqua ingresso/uscita 7/12°C - Portata aria nominale (3). Per le portate aria di funzionamento (ex. alle diverse Velocità, Segnali, ESP) vedi (8) (9); (4) acqua ingr. 7°C e portata acqua nominale (4). Raccomandato uso del SW.
 (2) Riscaldamento: Temp. aria 20°C - Temp. acqua ingresso/uscita 70/60°C - Portata aria nominale (3). Per le portate aria di funzionamento (ex. alle diverse Velocità, Segnali, ESP) vedi (8) (9); (5) acqua ingr. 70°C e portata acqua nominale (4). Raccomandato uso del SW.
 (3) (8) Portata aria e Press. statica: Valori nominali rilevati con cassone rif. norme AMCA210-74 fig.12 e condotto + diaframma rif. norme CEN-UNI10023.
 (4) Livelli sonori: Valori sonori in campo libero, distanza 2 m. Valori calcolati da potenza sonora rilevata in camera riverberante rif. norme ISO 3741 - ISO 3742.
 (5) Dati elettrici: Valori rilevati con Wattmetro Jakogawa WT10 (Valore max. nominale, di tarso motore = valore di riferimento per progettazione impianto elettrico). Per gli assorbimenti elettrici in funzionamento, classi efficienza energetica, ecc. vedi paragrafo "Tab. Regolamento UE-2016-2281".
 (6) Sound Levels: Free field sound pressure, 2 m distance. Data calculated based on sound power measured in reverberation room ref. ISO 3741 - ISO 3742 standards.
 (7) Electrical data: Data measured with Wattmeter Jakogawa WT10 (Max value, nominal of motor label = reference value for the electrical system design). For the operating electrical power absorption, energy efficiency class, etc. see paragraph "Tab. UE-2016-2281 Regulation".

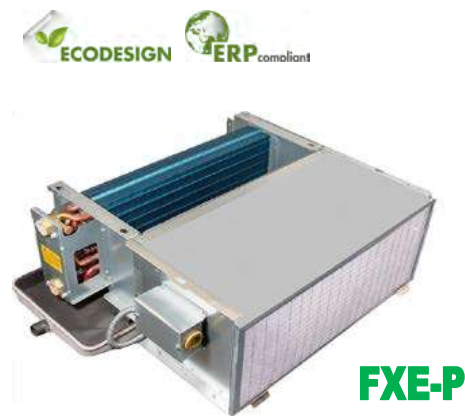

FXE-P

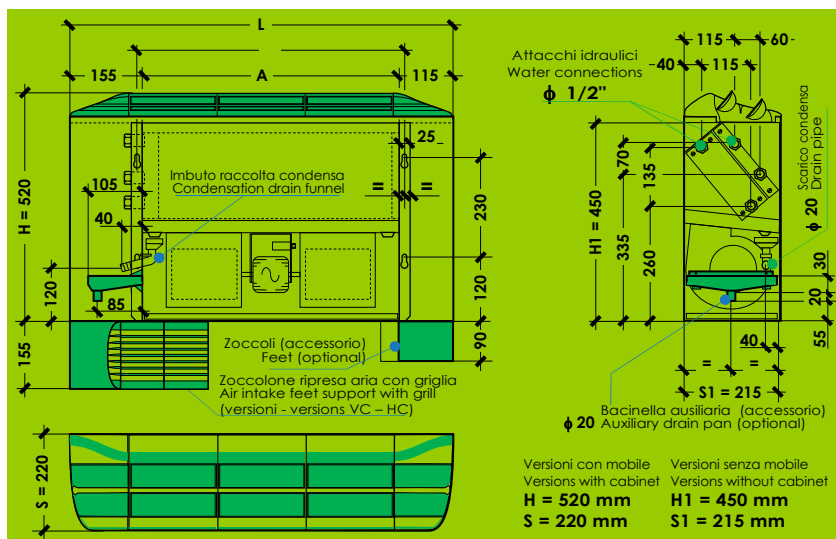

Versioni con mobile
Versions with cabinet
H = 520 mm
S = 220 mm

Versioni senza mobile
Versions without cabinet
H1 = 450 mm
S1 = 215 mm

Taglia - Size		DF-XE-P	131P	231P	331P	431P	531P	631P	731P	831P	931P	1031P	1131P	1231P
Potenz. Frigorifera Totale - Total (1) W			1.610	2.150	2.800	3.220	4.190	4.710	5.860	6.790	8.310	10.090	9.450	10.540
Cooling capacity Sensibile - Sensible (1) W			1.400	1.770	2.340	2.480	3.260	3.640	4.640	5.120	6.360	7.530	7.490	8.200
Potenzialità Termica - Heating capacity (2) W			2.100	2.210	3.640	3.720	5.070	5.270	6.880	7.080	9.100	9.370	11.120	11.230
Portata aria nominale - Nominal Air flow (3) m ³ /h			415	450	590	610	800	850	1.100	1.150	1.500	1.570	1.860	1.890
Portata acqua Raffred. - Cooling l/h			277	370	482	554	721	810	1.008	1.168	1.429	1.735	1.625	1.813
Water flow (4) Riscald. - Heating l/h			181	190	313	320	436	453	592	609	783	806	956	966
Perdite di carico acqua Raffred. - Cooling kPa			15,1	18,9	22,6	23,6	28,2	29,5	27,6	30,3	35,0	36,6	30,0	32,3
Water pressure drops (5) Riscald. - Heating kPa			9,1	10,0	15,3	15,9	28,5	30,7	49,2	52,0	48,9	51,8	48,7	49,7
Livelli sonori - Sound levels (6) Min-Med-Max dB(A)			13-29-40	13-30-43	16-33-47	16-35-48	16-29-42	16-31-44	17-36-48	17-37-49	20-43-52	20-44-53	17-40-51	17-40-51
Ref. FAN-DECK			SWP/STD.1/10, SWD/STD.1/10		SWP/STD.1/10, SWD/STD.1/10		SWP/Pot.1.1/10, SWD/Pot.1.1/10		SWP/Pot.1.1/10, SWD/Pot.1.1/10		SWP/FIX.1/10, SWD/FIX.1/10		SWP/FIX.1/10, SWD/FIX.1/10	
Motori/Ventilatori - Motors/Fans No./No.			1/1		1/1		1/2		1/2		1/2		1/3	
Absorb. elettrico nominale (Targa) MAX(7) W			55W		65W		85W		90W		180W		180W	
Nominal current input (Label) MAX(7) A			0,35A		0,45A		0,55A		0,55A		1,40A		1,40A	
Alimentazione elettrica - Power supply			230Vac-1Ph-50/60Hz (Signal 0...10Vdc)											
Batteria caldo/freddo Contenuto acqua - Water volume (l)			0,69	0,70	0,99	1,01	1,30	1,31	1,60	1,62	1,91	1,92	2,21	2,23
Heating/cooling coil [Ranghij], DN(*) - [Rows], DN(*)			[3R], 1/2" F		[3R], 1/2" F		[3R], 1/2" F		[3R], 1/2" F		[3R], 1/2" F		[3R], 1/2" F	
Batteria caldo Contenuto acqua - Water volume (l)			0,23		0,33		0,43		0,54		0,64		0,74	
Heating coil [Ranghij], DN(*) - [Rows], DN(*)			[1R], 1/2" F		[1R], 1/2" F		[1R], 1/2" F		[1R], 1/2" F		[1R], 1/2" F		[1R], 1/2" F	
Scarico condensa - Drain pipe φ (mm)			20		20		20		20		20		20	
Dimensioni principali Main dimensions	L	mm	670		870		1.070		1.270		1.470		1.670	
	H	mm	470		470		470		470		470		470	
	S	mm	220		220		220		220		220		220	
	A	mm	400		600		800		1.000		1.200		1.400	
B	mm	425		625		825		1.025		1.225		1.425		
Limite funzionam. inferiore Lower working limit	LFI ESP = 0 Pa	10V Med 1V	1,00 0,63 0,26	1,00 0,63 0,26	1,00 0,63 0,25	1,00 0,63 0,25	1,00 0,65 0,30	1,00 0,65 0,30	1,00 0,63 0,26	1,00 0,63 0,26	1,00 0,64 0,28	1,00 0,64 0,28	1,00 0,64 0,24	1,00 0,62 0,24
(8) 10V-Med-1V = Max-Med-Min RIDUZIONE PORTATA ARIA Coefficienti che definiscono le curve "Portata Aria / Pressione statica" (alle 3 velocità Max-Med-Min)	15 Pa	10V Med 1V	0,96 0,60 0,24	0,96 0,60 0,24	0,96 0,60 0,24	0,96 0,60 0,24	0,98 0,64 0,30	0,99 0,64 0,30	0,96 0,60 0,25	0,96 0,60 0,25	0,97 0,62 0,27	0,97 0,62 0,27	0,95 0,59 0,23	0,95 0,59 0,23
	30 Pa	10V Med 1V	0,89 0,57 0,23	0,90 0,56 0,23	0,92 0,58 0,23	0,92 0,58 0,23	0,95 0,62 0,29	0,95 0,62 0,29	0,91 0,57 0,24	0,91 0,57 0,24	0,93 0,60 0,26	0,93 0,60 0,26	0,91 0,56 0,22	0,91 0,56 0,22
	45 Pa	10V Med 1V	0,79 0,50 0,20	0,79 0,50 0,20	0,86 0,54 0,21	0,86 0,54 0,21	0,89 0,58 0,27	0,89 0,58 0,27	0,86 0,54 0,22	0,86 0,54 0,22	0,89 0,57 0,24	0,89 0,57 0,24	0,85 0,53 0,20	0,85 0,53 0,20
	60 Pa	10V Med 1V	0,64 0,40 0,16	0,64 0,40 0,16	0,74 0,47 0,18	0,74 0,47 0,18	0,81 0,53 0,24	0,81 0,53 0,24	0,80 0,50 0,21	0,80 0,50 0,21	0,83 0,53 0,23	0,83 0,53 0,23	0,83 0,48 0,19	0,83 0,48 0,19
	75 Pa	10V Med 1V	0,47 0,30 0,12	0,47 0,30 0,12	0,59 0,37 0,14	0,59 0,37 0,14	0,71 0,46 0,21	0,71 0,46 0,21	0,70 0,44 0,18	0,70 0,44 0,18	0,77 0,49 0,21	0,77 0,49 0,21	0,70 0,43 0,17	0,70 0,43 0,17
	90 Pa	10V Med 1V	0,32 0,20 \	0,32 0,20 \	0,39 0,25 \	0,39 0,25 \	0,56 0,36 0,17	0,56 0,36 0,17	0,58 0,37 0,15	0,58 0,37 0,15	0,71 0,45 0,19	0,71 0,45 0,19	0,61 0,38 0,15	0,61 0,38 0,15
LFS Limite funzionam. superiore Upper working limit	ESP (Pa)	10V	102 Pa	103 Pa	111 Pa	112 Pa	119 Pa	120 Pa	137 Pa	137 Pa	174 Pa	174 Pa	167 Pa	167 Pa
	Qa (x m ³ /h)		x 0,12	x 0,11	x 0,12	x 0,12	x 0,15	x 0,14	x 0,11	x 0,11	x 0,13	x 0,13	x 0,11	x 0,10
	ESP (Pa)	Med	99 Pa	100 Pa	106 Pa	106 Pa	114 Pa	115 Pa	131 Pa	132 Pa	168 Pa	169 Pa	158 Pa	158 Pa
	Qa (x m ³ /h)		x 0,11	x 0,10	x 0,11	x 0,11	x 0,15	x 0,14	x 0,11	x 0,10	x 0,13	x 0,12	x 0,10	x 0,10
ESP (Pa)	1V	81 Pa	83 Pa	87 Pa	88 Pa	98 Pa	100 Pa	111 Pa	112 Pa	140 Pa	141 Pa	125 Pa	125 Pa	
Qa (x m ³ /h)		x 0,11	x 0,10	x 0,10	x 0,10	x 0,14	x 0,13	x 0,10	x 0,10	x 0,12	x 0,12	x 0,09	x 0,09	

**(9) RIDUZIONE POTENZIALITÀ FRIGORIFERA/TERMICA (in funzione della riduzione portata aria)
COOLING/HEATING CAPACITY REDUCTION (depending on air flow reduction)**

Portata aria - Air flow	1.00	0.95	0.90	0.85	0.80	0.75	0.70	0.65	0.60	0.55	0.50	0.45	0.40	0.35	0.30	0.25	0.20	0.15
Potenzialità Frigorifera Totale - Total	1,00	0,97	0,95	0,92	0,89	0,87	0,84	0,81	0,77	0,74	0,71	0,67	0,63	0,59	0,55	0,50	0,45	0,39
Cooling capacity Sensibile - Sensible	1,00	0,97	0,93	0,90	0,86	0,83	0,79	0,76	0,72	0,68	0,64	0,60	0,55	0,51	0,46	0,41	0,35	0,29
Potenzialità termica - Heating capacity	1,00	0,97	0,94	0,91	0,87	0,84	0,81	0,77	0,74	0,70	0,66	0,62	0,58	0,53	0,49	0,44	0,38	0,32

DN(*) = Diametro nominale, F = Attacchi idraulici batteria gas femmina
 Dati tecnici riferiti alle seguenti condizioni: Unità Standard - Pressione atmosferica 1013 mbar - Alimentazione elettrica 230Vac/1Ph/50Hz.
 (1) (2) (3) (4) (5) Dati tecnici nominali, riferiti alla portata aria nom. (3) e Vmax=10V, ESP=0, batteria uscita. Per le prestazioni: (1) (2) alla portata aria di funzionamento riferita a B+H o al SW.
 (1) Raffreddamento: Temp. aria 20°C - Temp. acqua ingresso/uscita 7/12°C - Portata aria nominale (3). Per le portate aria di funzionamento (es. alle diverse velocità, segnali, ESP) vedi (8) e (9); rif. acqua ingr. 7°C e portata acqua nominale (4). Raccomandato uso del SW.
 (2) Riscaldamento: Temp. aria 20°C - Temp. acqua ingresso/uscita 70/60°C - Portata aria nominale (3). Per le portate aria di funzionamento (es. alle diverse velocità, segnali, ESP) vedi (8) e (9); rif. acqua ingr. 70°C e portata acqua nominale (4). Raccomandato uso del SW.
 (3) (4) (5) Rete Frigorifera e Termiche: Valori calcolati da SW e dati rilevati in camera cosmoestetica rif. norme UNI 7940 parte 1-2*, UNI-EN 1397/2001.
 (6) (7) Portata aria e Press. statica: Valori nominali rilevati con cassone rif. norme AMCA210-74 fig.12 e condotto a diametro rif. norme CNR-UNI10023.
 (8) Livelli sonori: Valori sonori in campo libero, distanza 2 m. Valori calcolati da potenza sonora rilevata in camera riverberante rif. norme ISO 3741 - ISO 3742.
 (9) Dati elettrici: Valori rilevati con Wattmetro Jokogawa WT110 (Valore max. nominale, di targa motore = valore di riferimento per progettazione impianto elettrico). Per gli assorbimenti elettrici in funzionamento, classi efficienza energetica, ecc. vedi paragrafo "Tab Regolamento UE-2016-2281".

DN(*) = Nominal diameter, F = Female gas water coil connections
 Technical data refer to the following conditions: Standard unit - Atmospheric pressure 1013 mbar - Power supply 230Vac/1Ph/50Hz.
 (1) (2) (3) (4) (5) Nominal technical data, refer to the nominal air flow (3) and Vmax=10V, ESP=0, dry coil. For the performances: (1) (2) in the operating air flow ref. B+H or the SW.
 (1) Cooling: Air temp.: 20°C (68°F) - Entering/leaving water temp.: 7/12°C (45/54°F) - Nominal air flow (3). For the operating air flows (ex. at the different Speed, Signals, ESP) see (8) and (9); ref. entering water temp.: 7°C and nominal water flow (4). Recommended use of the SW.
 (2) Heating: Air temp.: 20°C - Entering/leaving water temp.: 70/60°C - Nominal air flow (3). For the operating air flows (ex. at the different Speed, Signals, ESP) see (8) and (9); ref. entering water temp.: 70°C and nominal water flow (4). Recommended use of the SW.
 (3) (4) (5) Cooling and Heating Capacities: Data calculated by SW and measurements made in calorimetric room ref. UNI 7940 part 1-2*, UNI-EN 1397/2001 standards.
 (6) (7) Air flow and Static pressure: Nominal data measured with casing ref. AMCA210-74 fig.12 standards and plenum + diaphragm ref. CNR-UNI10023 standards.
 (8) Sound Levels: Free field sound pressure, 2 m distance. Data calculated based on sound power measured in reverberation room ref. ISO 3741 - ISO 3742 standards.
 (9) Electrical data: Data measured with Wattmeter Jokogawa WT110 (Max value, nominal of motor label = reference value for the electrical system design). For the operating electrical power absorption, energy efficiency class, etc. see paragraph "Tab UE-2016-2281 Regulation".

Versione verticale a parete (mobile base) Vertical wall version (basic cabinet)

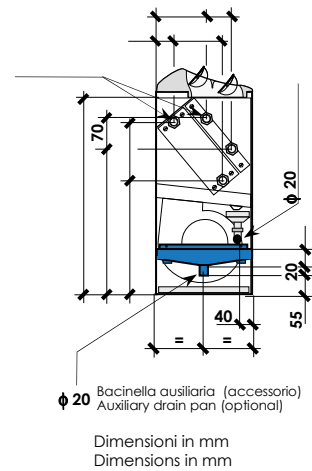
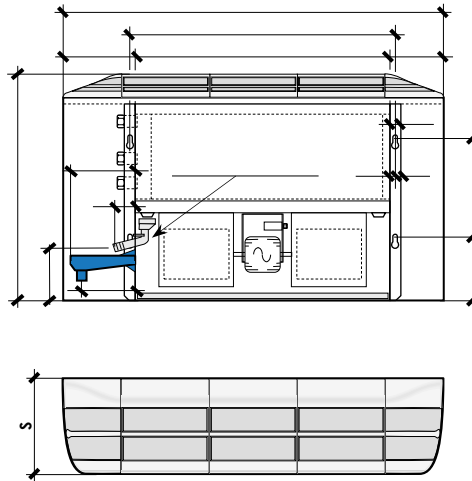
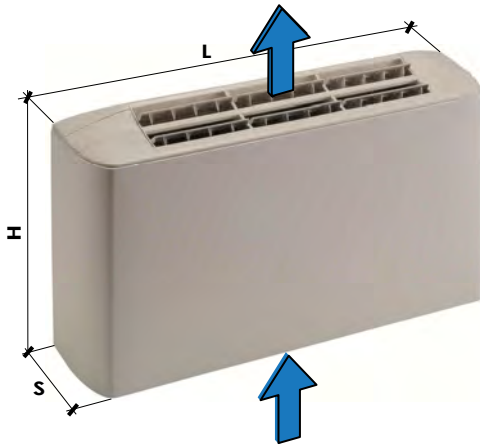

Taglia - Size		DF-X, FXE, ...	100	200	300	400	500	600	700	800	900	1000	1100	1200
Dimensioni principali Main dimensions	L	mm	670	670	870	870	1.070	1.070	1.270	1.270	1.470	1.470	1.670	1.670
	H	mm	520	520	520	520	520	520	520	520	520	520	520	520
	S	mm	220	220	220	220	220	220	220	220	220	220	220	220
	A	mm	400	400	600	600	800	800	1.000	1.000	1.200	1.200	1.400	1.400
	B	mm	425	425	625	625	825	825	1.025	1.025	1.225	1.225	1.425	1.425
N° Motori			1	1	1	1	1	1	1	1	1	1	1	1
N° Ventilatori			1	1	1	1	2	2	2	2	2	2	3	3
Batteria caldo/freddo Heating/cooling coil	Contenuto acqua Water volume (l)		0,69	0,70	0,99	1,01	1,30	1,31	1,60	1,62	1,91	1,92	2,21	2,23
	Ranghi - Rows DN(*)		3R 1/2" F	3R 1/2" F	3R 1/2" F	3R 1/2" F	3R 1/2" F	3R 1/2" F	3R 1/2" F	3R 1/2" F	3R 1/2" F	3R 1/2" F	3R 1/2" F	3R 1/2" F
Batteria caldo Heating coil	Contenuto acqua Water volume (l)		0,23	0,23	0,33	0,33	0,43	0,43	0,54	0,54	0,64	0,64	0,74	0,74
	Ranghi - Rows DN(*)		1R 1/2" F	1R 1/2" F	1R 1/2" F	1R 1/2" F	1R 1/2" F	1R 1/2" F	1R 1/2" F	1R 1/2" F	1R 1/2" F	1R 1/2" F	1R 1/2" F	1R 1/2" F
Scarico condensa - Drain pipe		φ(mm)	20	20	20	20	20	20	20	20	20	20	20	20
FX	Ref. FAN-DECK		C2, A40.6V, [P2-3-5],[N1-2-4]		C3,15, A40.6V, [P2-3-5],[N1-2-4]		C3,15, A80.6V, [P2-3-5],[N1-2-4]		C5, A80.6V, [P2-3-5],[N1-2-4]		C3,15, A80.6V, [P2-3-5],[N1-2-4]		C3,15, 5V, [P2-3-4],[N1-3-4]	
	Peso netto 2 Tubi/Pipe	Kg	13,5	14,0	16,4	17,2	22,5	23,5	26,0	27,5	30,0	31,5	32,9	36,4
	Net weight 4 Tubi/Pipe	Kg	14,4	14,9	17,4	18,2	23,6	24,6	27,2	28,7	31,3	32,8	34,3	37,8
FX-P	Ref. FAN-DECK		C3,15, A40.6V, [P2-3-5],[N1-2-4]		C3,15, A80.6V, [P2-3-5],[N1-2-4]		C2, A80.6V, [P2-3-5],[N1-2-4]		C4, A80.6V, [P2-3-5],[N1-2-4]		C4, 6V, [P2-3-4],[N1-3-5]		C4, 5V, [P2-3-4],[N1-3-4]	
	Peso netto 2 Tubi/Pipe	Kg	14,1	14,6	17,2	18,0	23,0	24,0	26,9	28,4	31,1	32,6	34,0	37,5
	Net weight 4 Tubi/Pipe	Kg	15,0	15,5	18,2	19,0	24,1	25,1	28,1	29,6	32,4	33,9	35,4	38,9
FX-S	Ref. FAN-DECK		C1,5, A40.6V, [P4-5-6],[N4-5-6]		C2,5, A40.6V, [P4-5-6],[N4-5-6]		C2,5, A80.6V, [P4-5-6],[N4-5-6]		C4, A80.6V, [P4-5-6],[N4-5-6]		C2,5, A80.6V, [P4-5-6],[N4-5-6]		C4, V3-A240, [P4-5-6],[N4-5-6]	
	Peso netto 2 Tubi/Pipe	Kg	14,2	14,7	17,1	17,9	23,2	24,2	26,7	28,2	30,7	32,2	33,6	37,1
	Net weight 4 Tubi/Pipe	Kg	15,1	15,6	18,1	18,9	24,3	25,3	27,9	29,4	32,0	33,5	35,0	38,5
FXE	Ref. FAN-DECK		SWP/STD.1/10, SWN/STD.1/10		SWP/STD.1/10, SWN/STD.1/10		SWP/STD.1/10, SWN/PotD.1/10		SWP/STD.1/10, SWN/PotD.1/10		SWP/STD.1/10, SWN/PotD.1/10		SWP/RX.1/10, SWD/RXD.1/10	
	Peso netto 2 Tubi/Pipe	Kg	13,1	13,6	16,5	17,3	22,9	23,9	25,9	27,4	29,1	30,6	32,7	36,2
	Net weight 4 Tubi/Pipe	Kg	14,0	14,5	17,5	18,3	24,0	25,0	27,1	28,6	30,4	31,9	34,1	37,6
FXE-P	Ref. FAN-DECK		SWP/STD.1/10, SWD/STD.1/10		SWP/STD.1/10, SWD/STD.1/10		SWP/PotD.1/10, SWD/PotD.1/10		SWP/PotD.1/10, SWD/PotD.1/10		SWP/RX.1/10, SWD/RX.1/10		SWP/RX.1/10, SWD/RX.1/10	
	Peso netto 2 Tubi/Pipe	Kg	13,4	13,9	16,8	17,6	23,2	24,2	26,2	27,7	29,4	30,9	33,0	36,5
	Net weight 4 Tubi/Pipe	Kg	14,3	14,8	17,8	18,6	24,3	25,3	27,4	28,9	30,7	32,2	34,4	37,9
FXE-S	Ref. FAN-DECK		SWP/STD.1/7, SWD/STD.1/7		SWP/STD.1/7, SWD/STD.1/7		SWP/STD.1/7, SWD/STD.1/7		SWP/STD.1/8, SWD/STD.1/8		SWP/STD.1/9, SWD/STD.1/9		SWP/RX.1/10, SWD/RXD.2/10	
	Peso netto 2 Tubi/Pipe	Kg	14,1	14,6	17,5	18,3	23,9	24,9	26,9	28,4	30,1	31,6	33,7	37,2
	Net weight 4 Tubi/Pipe	Kg	15,0	15,5	18,5	19,3	25,0	26,0	28,1	29,6	31,4	32,9	35,1	38,6
FXE+	Ref. FAN-DECK		SWP/STD.1/10, SWN/STD.1/10		SWP/STD.1/10, SWN/STD.1/10		Non disponibile		Non disponibile		Non disponibile		Non disponibile	
	Peso netto 2 Tubi/Pipe	Kg	13,9	14,4	17,3	18,1	Not available		Not available		Not available		Not available	
	Net weight 4 Tubi/Pipe	Kg	14,8	15,3	18,3	19,1	Not available		Not available		Not available		Not available	
DN(*) = Diametro nominale, F = Attacchi idraulici batteria Gas femmina DN(*) = Nominal diameter, F = Female gas water coil connections														
▪ Peso netto= solo unità, escluso imballo ▪ Net weight= unit only, excluding packaging														

Versione verticale a pavimento (mobile con griglia aspirazione aria frontale) Vertical floor version (cabinet with front air intake grill)

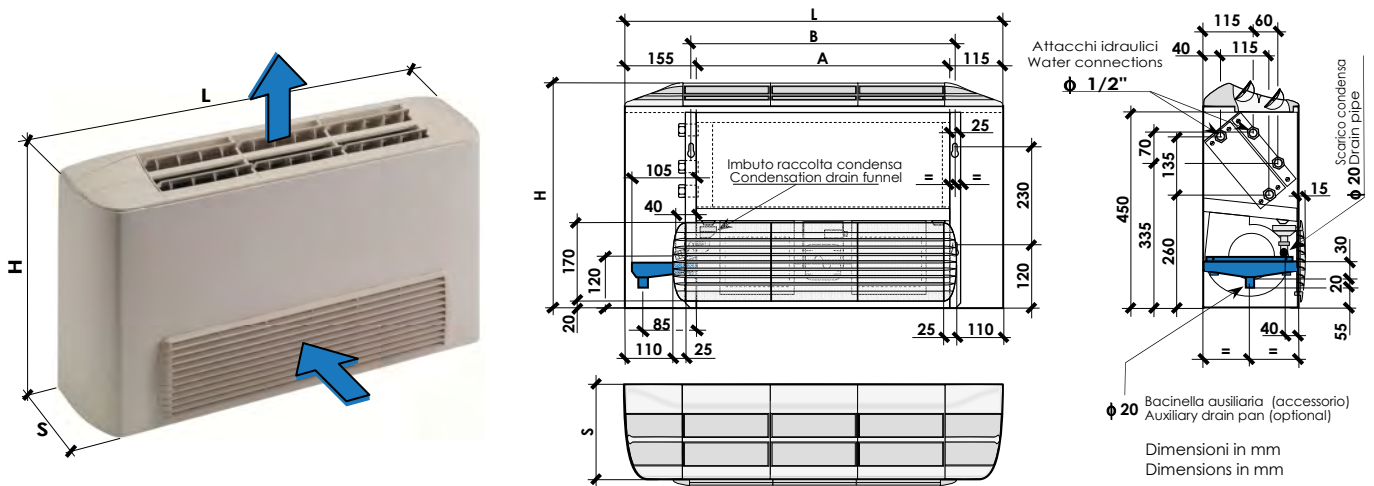

Taglia - Size		DF-X, FXE, ...	100	200	300	400	500	600	700	800	900	1000	1100	1200
Dimensioni principali Main dimensions	L	mm	670	670	870	870	1.070	1.070	1.270	1.270	1.470	1.470	1.670	1.670
	H	mm	520	520	520	520	520	520	520	520	520	520	520	520
	S	mm	220	220	220	220	220	220	220	220	220	220	220	220
	A	mm	400	400	600	600	800	800	1.000	1.000	1.200	1.200	1.400	1.400
	B	mm	425	425	625	625	825	825	1.025	1.025	1.225	1.225	1.425	1.425
N° Motori			1	1	1	1	1	1	1	1	1	1	1	1
N° Ventilatori			1	1	1	1	2	2	2	2	2	2	3	3
Batteria caldo/freddo Heating/cooling coil	Contenuto acqua Water volume (l)		0,69	0,70	0,99	1,01	1,30	1,31	1,60	1,62	1,91	1,92	2,21	2,23
	Ranghi - Rows DN(*)		3R 1/2" F	3R 1/2" F	3R 1/2" F	3R 1/2" F	3R 1/2" F	3R 1/2" F	3R 1/2" F	3R 1/2" F	3R 1/2" F	3R 1/2" F	3R 1/2" F	3R 1/2" F
Batteria caldo Heating coil	Contenuto acqua Water volume (l)		0,23	0,23	0,33	0,33	0,43	0,43	0,54	0,54	0,64	0,64	0,74	0,74
	Ranghi - Rows DN(*)		1R 1/2" F	1R 1/2" F	1R 1/2" F	1R 1/2" F	1R 1/2" F	1R 1/2" F	1R 1/2" F	1R 1/2" F	1R 1/2" F	1R 1/2" F	1R 1/2" F	1R 1/2" F
Scarico condensa - Drain pipe		ø(mm)	20	20	20	20	20	20	20	20	20	20	20	20
FX	Ref. FAN-DECK		C2, A40.6V, [P2-3-5],[N1-2-4]		C3.15, A40.6V, [P2-3-5],[N1-2-4]		C3.15, A80.6V, [P2-3-5],[N1-2-4]		C5, A80.6V, [P2-3-5],[N1-2-4]		C3.15, A80.6V, [P2-3-5],[N1-2-4]		C3.15, 5V, [P2-3-4],[ND.1-3-4]	
	Peso netto 2 Tubi/Pipe	Kg	13,8	14,3	16,9	17,7	23,2	24,2	26,9	28,4	31,1	32,6	34,2	37,7
	Net weight 4 Tubi/Pipe	Kg	14,7	15,2	17,9	18,7	24,3	25,3	28,1	29,6	32,4	33,9	35,6	39,1
FX-P	Ref. FAN-DECK		C3.15, A40.6V, [P2-3-5],[N1-2-4]		C3.15, A80.6V, [P2-3-5],[N1-2-4]		C2, A80.6V, [P2-3-5],[N1-2-4]		C4, A80.6V, [P2-3-5],[N1-2-4]		C4, 6V, [P2-3-4],[N1-3-5]		C4, 5V, [P2-3-4],[N1-3-4]	
	Peso netto 2 Tubi/Pipe	Kg	14,4	14,9	17,7	18,5	23,7	24,7	27,8	29,3	32,2	33,7	35,3	38,8
	Net weight 4 Tubi/Pipe	Kg	15,3	15,8	18,7	19,5	24,8	25,8	29,0	30,5	33,5	35,0	36,7	40,2
FX-S	Ref. FAN-DECK		C1.5, A40.6V, [P4-5-6],[N4-5-6]		C2.5, A40.6V, [P4-5-6],[N4-5-6]		C2.5, A80.6V, [P4-5-6],[N4-5-6]		C4, A80.6V, [P4-5-6],[N4-5-6]		C2.5, A80.6V, [P4-5-6],[N4-5-6]		C4, V3-A240, [P4-5-6],[N4-5-6]	
	Peso netto 2 Tubi/Pipe	Kg	14,5	15,0	17,6	18,4	23,9	24,9	27,6	29,1	31,8	33,3	34,9	38,4
	Net weight 4 Tubi/Pipe	Kg	15,4	15,9	18,6	19,4	25,0	26,0	28,8	30,3	33,1	34,6	36,3	39,8
FXE	Ref. FAN-DECK		SWP/STD.1/10, SWN/STD.1/10		SWP/STD.1/10, SWN/STD.1/10		SWP/STD.1/10, SWN/PotID.1/10		SWP/STD.1/10, SWN/PotID.1/10		SWP/STD.1/10, SWN/Pot1.1/10		SWP/RX.1/10, SWD/RXD.1/10	
	Peso netto 2 Tubi/Pipe	Kg	13,4	13,9	17,0	17,8	23,6	24,6	26,8	28,3	30,2	31,7	34,0	37,5
	Net weight 4 Tubi/Pipe	Kg	14,3	14,8	18,0	18,8	24,7	25,7	28,0	29,5	31,5	33,0	35,4	38,9
FXE-P	Ref. FAN-DECK		SWP/STD.1/10, SWD/STD.1/10		SWP/STD.1/10, SWD/STD.1/10		SWP/Pot1.1/10, SWD/Pot1.1/10		SWP/Pot1.1/10, SWD/Pot1.1/10		SWP/RX.1/10, SWD/RX.1/10		SWP/RX.1/10, SWD/RX.1/10	
	Peso netto 2 Tubi/Pipe	Kg	13,7	14,2	17,3	18,1	23,9	24,9	27,1	28,6	30,5	32,0	34,3	37,8
	Net weight 4 Tubi/Pipe	Kg	14,6	15,1	18,3	19,1	25,0	26,0	28,3	29,8	31,8	33,3	35,7	39,2
FXE-S	Ref. FAN-DECK		SWP/STD.1/7, SWD/STD.1/7		SWP/STD.1/7, SWD/STD.1/7		SWP/STD.1/7, SWD/STD.1/7		SWP/STD.1/8, SWD/STD.1/8		SWP/STD.1/9, SWD/STD.1/9		SWP/RX.1/10, SWD/RXD.2/10	
	Peso netto 2 Tubi/Pipe	Kg	14,4	14,9	18,0	18,8	24,6	25,6	27,8	29,3	31,2	32,7	35,0	38,5
	Net weight 4 Tubi/Pipe	Kg	15,3	15,8	19,0	19,8	25,7	26,7	29,0	30,5	32,5	34,0	36,4	39,9
FXE+	Ref. FAN-DECK		SWP/STD.1/10, SWN/STD.1/10		SWP/STD.1/10, SWN/STD.1/10		Non disponibile		Non disponibile		Non disponibile		Non disponibile	
	Peso netto 2 Tubi/Pipe	Kg	14,2	14,7	17,8	18,6	Not available		Not available		Not available		Not available	
	Net weight 4 Tubi/Pipe	Kg	15,1	15,6	18,8	19,6	Not available		Not available		Not available		Not available	

DN(*) = Diametro nominale, F = Attacchi idraulici batteria Gas femmina

DN(*) = Nominal diameter, F = Female gas water coil connections

▪ Peso netto= solo unità, escluso imballo

▪ Net weight= unit only, excluding packaging

Versione orizzontale a soffitto (mobile base) Horizontal ceiling version (basic cabinet)

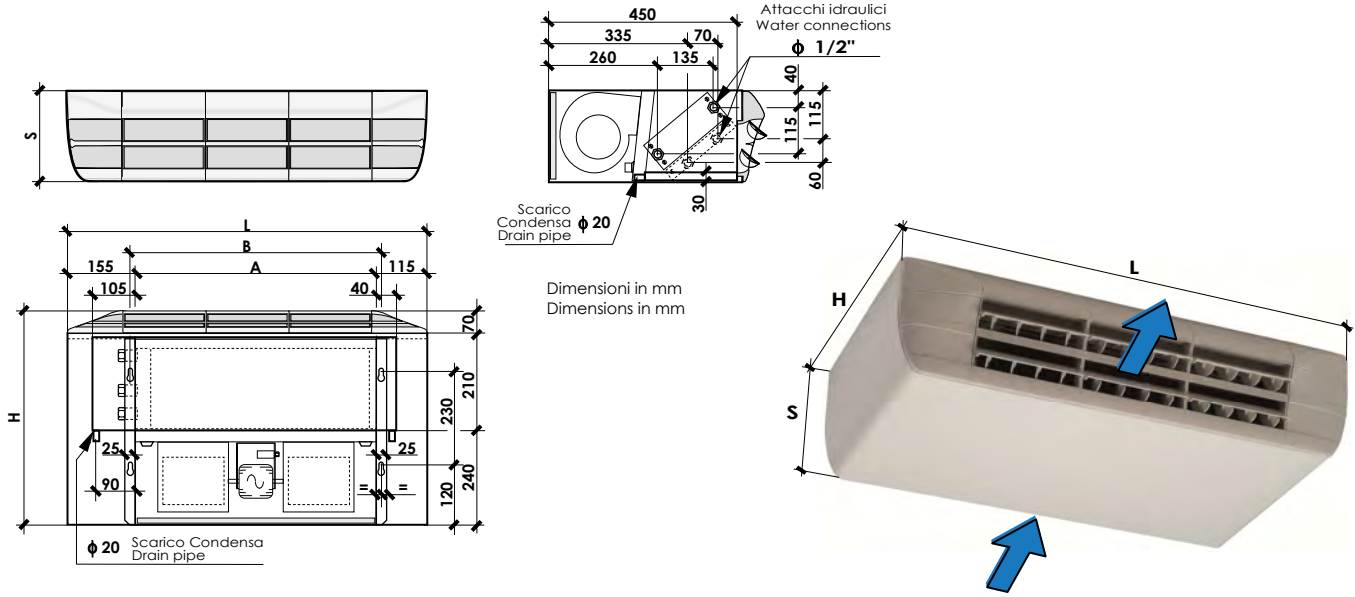

Taglia - Size		DF-X, FXE, ...	100	200	300	400	500	600	700	800	900	1000	1100	1200	
Dimensioni principali Main dimensions	L	mm	670	670	870	870	1.070	1.070	1.270	1.270	1.470	1.470	1.670	1.670	
	H	mm	520	520	520	520	520	520	520	520	520	520	520	520	
	S	mm	220	220	220	220	220	220	220	220	220	220	220	220	
	A	mm	400	400	600	600	800	800	1.000	1.000	1.200	1.200	1.400	1.400	
	B	mm	425	425	625	625	825	825	1.025	1.025	1.225	1.225	1.425	1.425	
N° Motori N° Ventilatori			1 1	1 1	1 1	1 1	1 2	1 2	1 2	1 2	1 2	1 2	1 3	1 3	
Batteria caldo/freddo Heating/cooling coil	Contenuto acqua Water volume (l)		0,69	0,70	0,99	1,01	1,30	1,31	1,60	1,62	1,91	1,92	2,21	2,23	
	Ranghi - Rows DN(*)		3R 1/2" F	3R 1/2" F	3R 1/2" F	3R 1/2" F	3R 1/2" F	3R 1/2" F	3R 1/2" F	3R 1/2" F	3R 1/2" F	3R 1/2" F	3R 1/2" F	3R 1/2" F	
Batteria caldo Heating coil	Contenuto acqua Water volume (l)		0,23	0,23	0,33	0,33	0,43	0,43	0,54	0,54	0,64	0,64	0,74	0,74	
	Ranghi - Rows DN(*)		1R 1/2" F	1R 1/2" F	1R 1/2" F	1R 1/2" F	1R 1/2" F	1R 1/2" F	1R 1/2" F	1R 1/2" F	1R 1/2" F	1R 1/2" F	1R 1/2" F	1R 1/2" F	
Scarico condensa - Drain pipe			φ(mm)		20	20	20	20	20	20	20	20	20	20	
FX	Ref. FAN-DECK		C2. A40.6V. [P2-3-5].[N1-2-4]		C3.15. A40.6V. [P2-3-5].[N1-2-4]		C3.15. A80.6V. [P2-3-5].[N1-2-4]		C5. A80.6V. [P2-3-5].[N1-2-4]		C3.15. A80.6V. [P2-3-5].[N1-2-4]		C3.15. 5V. [P2-3-4].[ND.1-3-4]		
	Peso netto Net weight	2 Tubi/Pipe 4 Tubi/Pipe	Kg	14,7 15,6	15,2 16,1	18,0 19,0	18,8 19,8	24,5 25,6	25,5 26,6	28,4 29,6	29,9 31,1	32,8 34,1	34,3 35,6	36,1 37,5	
FX-P	Ref. FAN-DECK		C3.15. A40.6V. [P2-3-5].[N1-2-4]		C3.15. A80.6V. [P2-3-5].[N1-2-4]		C2. A80.6V. [P2-3-5].[N1-2-4]		C4. A80.6V. [P2-3-5].[N1-2-4]		C4. 6V. [P2-3-4].[N1-3-5]		C4. 5V. [P2-3-4].[N1-3-4]		
	Peso netto Net weight	2 Tubi/Pipe 4 Tubi/Pipe	Kg	15,3 16,2	15,8 16,7	18,8 19,8	19,6 20,6	25,0 26,1	26,0 27,1	29,3 30,5	30,8 32,0	33,9 35,2	35,4 36,7	37,2 38,6	
FX-S	Ref. FAN-DECK		C1.5. A40.6V. [P4-5-6].[N4-5-6]		C2.5. A40.6V. [P4-5-6].[N4-5-6]		C2.5. A80.6V. [P4-5-6].[N4-5-6]		C4. A80.6V. [P4-5-6].[N4-5-6]		C2.5. A80.6V. [P4-5-6].[N4-5-6]		C4. V3-A240. [P4-5-6].[N4-5-6]		
	Peso netto Net weight	2 Tubi/Pipe 4 Tubi/Pipe	Kg	15,4 16,3	15,9 16,8	18,7 19,7	19,5 20,5	25,2 26,3	26,2 27,3	29,1 30,3	30,6 31,8	33,5 34,8	35,0 36,3	36,8 38,2	
FXE	Ref. FAN-DECK		SWP/STD.1/10. SWN/STD.1/10		SWP/STD.1/10. SWN/STD.1/10		SWP/STD.1/10. SWN/Pot1.D.1/10		SWP/STD.1/10. SWN/Pot1.D.1/10		SWP/STD.1/10. SWN/Pot1.1/10		SWP/FIX.1/10. SWD/FIXD.1/10		
	Peso netto Net weight	2 Tubi/Pipe 4 Tubi/Pipe	Kg	14,3 15,2	14,8 15,7	18,1 19,1	18,9 19,9	24,9 26,0	25,9 27,0	28,3 29,5	29,8 31,0	31,9 33,2	33,4 34,7	35,9 37,3	
FXE-P	Ref. FAN-DECK		SWP/STD.1/10. SWD/STD.1/10		SWP/STD.1/10. SWD/STD.1/10		SWP/Pot1.1/10. SWD/Pot1.1/10		SWP/Pot1.1/10. SWD/Pot1.1/10		SWP/FIX.1/10. SWD/FIX.1/10		SWP/FIX.1/10. SWD/FIXD.1/10		
	Peso netto Net weight	2 Tubi/Pipe 4 Tubi/Pipe	Kg	14,6 15,5	15,1 16,0	18,4 19,4	19,2 20,2	25,2 26,3	26,2 27,3	28,6 29,8	30,1 31,3	32,2 33,5	33,7 35,0	36,2 37,6	
FXE-S	Ref. FAN-DECK		SWP/STD.1/7. SWD/STD.1/7		SWP/STD.1/7. SWD/STD.1/7		SWP/STD.1/7. SWD/STD.1/7		SWP/STD.1/8. SWD/STD.1/8		SWP/STD.1/9. SWD/STD.1/9		SWP/FIX.1/10. SWD/FIXD.2.1/10		
	Peso netto Net weight	2 Tubi/Pipe 4 Tubi/Pipe	Kg	15,3 16,2	15,8 16,7	19,1 20,1	19,9 20,9	25,9 27,0	26,9 28,0	29,3 30,5	30,8 32,0	32,9 34,2	34,4 35,7	36,9 38,3	
FXE+	Ref. FAN-DECK		SWP/STD.1/10. SWN/STD.1/10		SWP/STD.1/10. SWN/STD.1/10		Non disponibile Not available		Non disponibile Not available		Non disponibile Not available		Non disponibile Not available		
	Peso netto Net weight	2 Tubi/Pipe 4 Tubi/Pipe	Kg	15,1 16,0	15,6 16,5	18,9 19,9	19,7 20,7								

DN(*) = Diametro nominale, F = Attacchi idraulici batteria Gas femmina

DN(*) = Nominal diameter, F = Female gas water coil connections

▪ Peso netto= solo unità, escluso imballo

▪ Net weight= unit only, excluding packaging

FX-HB

Versione orizzontale a soffitto (mobile con griglia aspirazione aria frontale) Horizontal ceiling version (cabinet with front air intake grill)

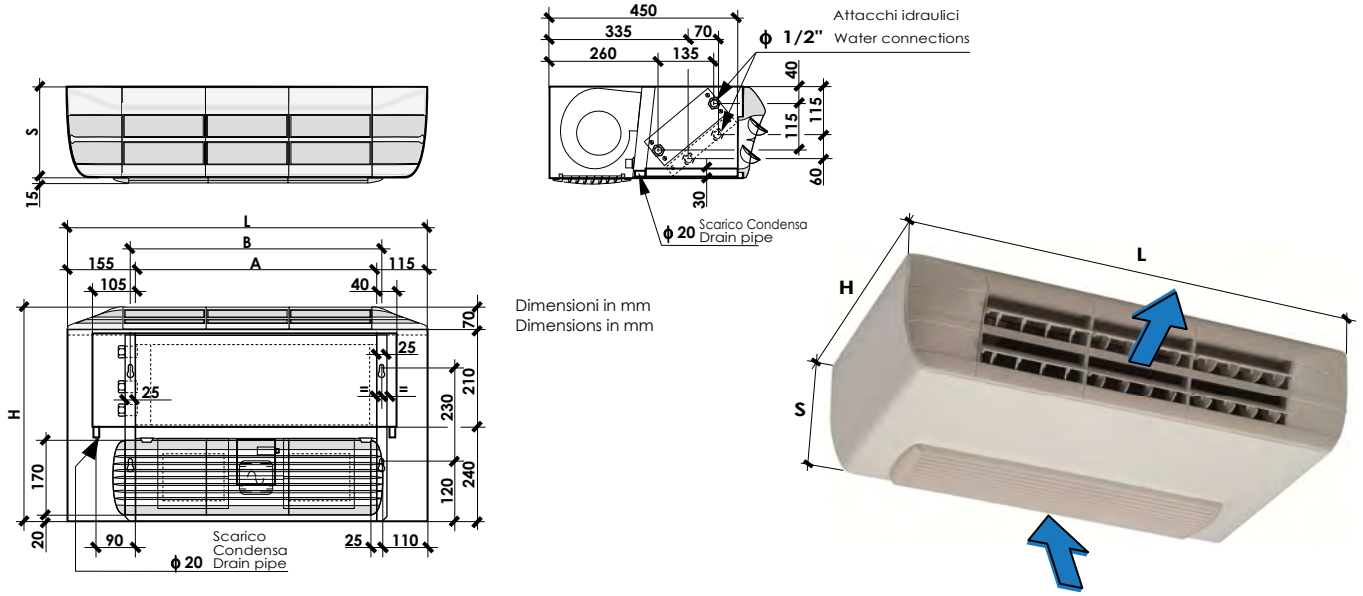

Taglia - Size			DF-X, FXE, ...	100	200	300	400	500	600	700	800	900	1000	1100	1200
Dimensioni principali Main dimensions	L	mm		670	670	870	870	1.070	1.070	1.270	1.270	1.470	1.470	1.670	1.670
	H	mm		520	520	520	520	520	520	520	520	520	520	520	520
	S	mm		220	220	220	220	220	220	220	220	220	220	220	220
	A	mm		400	400	600	600	800	800	1.000	1.000	1.200	1.200	1.400	1.400
	B	mm		425	425	625	625	825	825	1.025	1.025	1.225	1.225	1.425	1.425
N° Motori N° Ventilatori				1	1	1	1	1	1	1	1	1	1	1	1
Batteria caldo/freddo Heating/cooling coil	Contenuto acqua Water volume (l)			0,69	0,70	0,99	1,01	1,30	1,31	1,60	1,62	1,91	1,92	2,21	2,23
	Ranghi - Rows DN(*)			3R 1/2" F	3R 1/2" F	3R 1/2" F	3R 1/2" F	3R 1/2" F	3R 1/2" F	3R 1/2" F	3R 1/2" F	3R 1/2" F	3R 1/2" F	3R 1/2" F	3R 1/2" F
Batteria caldo Heating coil	Contenuto acqua Water volume (l)			0,23	0,23	0,33	0,33	0,43	0,43	0,54	0,54	0,64	0,64	0,74	0,74
	Ranghi - Rows DN(*)			1R 1/2" F	1R 1/2" F	1R 1/2" F	1R 1/2" F	1R 1/2" F	1R 1/2" F	1R 1/2" F	1R 1/2" F	1R 1/2" F	1R 1/2" F	1R 1/2" F	1R 1/2" F
Scarico condensa - Drain pipe			φ(mm)	20	20	20	20	20	20	20	20	20	20	20	20
FX	Ref. FAN-DECK			C2, A40.6V, [P2-3-5],[N1-2-4]		C3.15, A40.6V, [P2-3-5],[N1-2-4]		C3.15, A80.6V, [P2-3-5],[N1-2-4]		C5, A80.6V, [P2-3-5],[N1-2-4]		C3.15, A80.6V, [P2-3-5],[N1-2-4]		C3.15, 5V, [P2-3-4],[ND.1-3-4]	
	Peso netto	2 Tubi/Pipe	Kg	15,0	15,5	18,5	19,3	25,2	26,2	29,3	30,8	33,9	35,4	37,4	40,9
	Net weight	4 Tubi/Pipe	Kg	15,9	16,4	19,5	20,3	26,3	27,3	30,5	32,0	35,2	36,7	38,8	42,3
FX-P	Ref. FAN-DECK			C3.15, A40.6V, [P2-3-5],[N1-2-4]		C3.15, A80.6V, [P2-3-5],[N1-2-4]		C2, A80.6V, [P2-3-5],[N1-2-4]		C4, A80.6V, [P2-3-5],[N1-2-4]		C4, 6V, [P2-3-4],[N1-3-5]		C4, 5V, [P2-3-4],[N1-3-4]	
	Peso netto	2 Tubi/Pipe	Kg	15,6	16,1	19,3	20,1	25,7	26,7	30,2	31,7	35,0	36,5	38,5	42,0
	Net weight	4 Tubi/Pipe	Kg	16,5	17,0	20,3	21,1	26,8	27,8	31,4	32,9	36,3	37,8	39,9	43,4
FX-S	Ref. FAN-DECK			C1.5, A40.6V, [P4-5-6],[N4-5-6]		C2.5, A40.6V, [P4-5-6],[N4-5-6]		C2.5, A80.6V, [P4-5-6],[N4-5-6]		C4, A80.6V, [P4-5-6],[N4-5-6]		C2.5, A80.6V, [P4-5-6],[N4-5-6]		C4, V3-A240, [P4-5-6],[N4-5-6]	
	Peso netto	2 Tubi/Pipe	Kg	15,7	16,2	19,2	20,0	25,9	26,9	30,0	31,5	34,6	36,1	38,1	41,6
	Net weight	4 Tubi/Pipe	Kg	16,6	17,1	20,2	21,0	27,0	28,0	31,2	32,7	35,9	37,4	39,5	43,0
FXE	Ref. FAN-DECK			SWP/STD.1/10, SWN/STD.1/10		SWP/STD.1/10, SWN/STD.1/10		SWP/STD.1/10, SWN/Pot1.D.1/10		SWP/STD.1/10, SWN/Pot1.D.1/10		SWP/STD.1/10, SWN/Pot1.1/10		SWP/FIX.1/10, SWD/FIXD.1/10	
	Peso netto	2 Tubi/Pipe	Kg	14,6	15,1	18,6	19,4	25,6	26,6	29,2	30,7	33,0	34,5	37,2	40,7
	Net weight	4 Tubi/Pipe	Kg	15,5	16,0	19,6	20,4	26,7	27,7	30,4	31,9	34,3	35,8	38,6	42,1
FXE-P	Ref. FAN-DECK			SWP/STD.1/10, SWD/STD.1/10		SWP/STD.1/10, SWD/STD.1/10		SWP/Pot1.1/10, SWD/Pot1.1/10		SWP/Pot1.1/10, SWD/Pot1.1/10		SWP/FIX.1/10, SWD/FIX.1/10		SWP/FIX.1/10, SWD/FIXD.1/10	
	Peso netto	2 Tubi/Pipe	Kg	14,9	15,4	18,9	19,7	25,9	26,9	29,5	31,0	33,3	34,8	37,5	41,0
	Net weight	4 Tubi/Pipe	Kg	15,8	16,3	19,9	20,7	27,0	28,0	30,7	32,2	34,6	36,1	38,9	42,4
FXE-S	Ref. FAN-DECK			SWP/STD.1/7, SWD/STD.1/7		SWP/STD.1/7, SWD/STD.1/7		SWP/STD.1/7, SWD/STD.1/7		SWP/STD.1/8, SWD/STD.1/8		SWP/STD.1/9, SWD/STD.1/9		SWP/FIX.1/10, SWD/FIXD.2.1/10	
	Peso netto	2 Tubi/Pipe	Kg	15,6	16,1	19,6	20,4	26,6	27,6	30,2	31,7	34,0	35,5	38,2	41,7
	Net weight	4 Tubi/Pipe	Kg	16,5	17,0	20,6	21,4	27,7	28,7	31,4	32,9	35,3	36,8	39,6	43,1
FXE+	Ref. FAN-DECK			SWP/STD.1/10, SWN/STD.1/10		SWP/STD.1/10, SWN/STD.1/10		Non disponibile Not available		Non disponibile Not available		Non disponibile Not available		Non disponibile Not available	
	Peso netto	2 Tubi/Pipe	Kg	15,4	15,9	19,4	20,2								
	Net weight	4 Tubi/Pipe	Kg	16,3	16,8	20,4	21,2								

DN(*) = Diametro nominale, F = Attacchi idraulici batteria Gas femmina

DN(*) = Nominal diameter, F = Female gas water coil connections

▪ Peso netto= solo unità, escluso imballo

▪ Net weight= unit only, excluding packaging

FX-HC

Versione orizzontale a soffitto (mobile con zoccolone+griglia aspirazione aria) Horizontal ceiling version (cabinet with air intake feet support+grill)

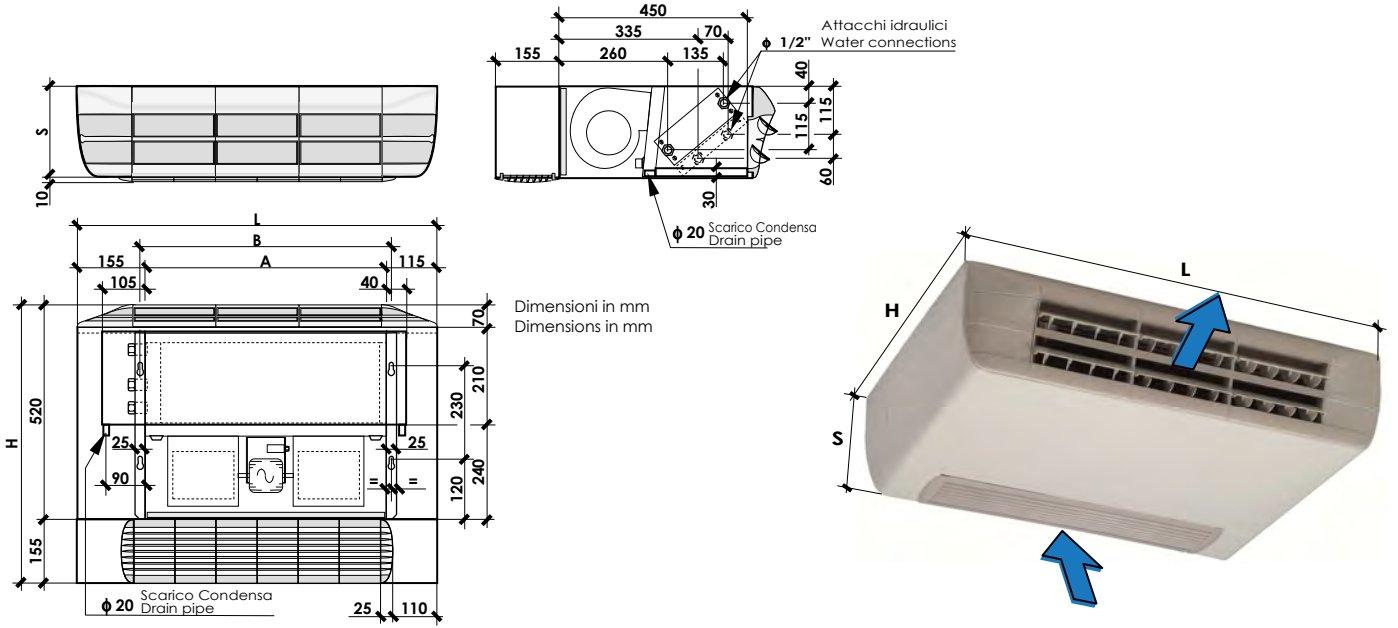

Taglia - Size		DF-X, FXE, ...	100	200	300	400	500	600	700	800	900	1000	1100	1200	
Dimensioni principali Main dimensions	L	mm	670	670	870	870	1.070	1.070	1.270	1.270	1.470	1.470	1.670	1.670	
	H	mm	675	675	675	675	675	675	675	675	675	675	675	675	
	S	mm	220	220	220	220	220	220	220	220	220	220	220	220	
	A	mm	400	400	600	600	800	800	1.000	1.000	1.200	1.200	1.400	1.400	
	B	mm	425	425	625	625	825	825	1.025	1.025	1.225	1.225	1.425	1.425	
N° Motori			1	1	1	1	1	1	1	1	1	1	1	1	
N° Ventilatori			1	1	1	1	2	2	2	2	2	2	3	3	
Batteria caldo/freddo Heating/cooling coil	Contenuto acqua Water volume (l)		0,69	0,70	0,99	1,01	1,30	1,31	1,60	1,62	1,91	1,92	2,21	2,23	
	Ranghi - Rows DN(*)		3R 1/2" F	3R 1/2" F	3R 1/2" F	3R 1/2" F	3R 1/2" F	3R 1/2" F	3R 1/2" F	3R 1/2" F	3R 1/2" F	3R 1/2" F	3R 1/2" F	3R 1/2" F	
Batteria caldo Heating coil	Contenuto acqua Water volume (l)		0,23	0,23	0,33	0,33	0,43	0,43	0,54	0,54	0,64	0,64	0,74	0,74	
	Ranghi - Rows DN(*)		1R 1/2" F	1R 1/2" F	1R 1/2" F	1R 1/2" F	1R 1/2" F	1R 1/2" F	1R 1/2" F	1R 1/2" F	1R 1/2" F	1R 1/2" F	1R 1/2" F	1R 1/2" F	
Scarico condensa - Drain pipe			φ(mm)	20	20	20	20	20	20	20	20	20	20	20	
FX	Ref. FAN-DECK		C2. A40.6V. [P2-3-5],[N1-2-4]		C3.15. A40.6V. [P2-3-5],[N1-2-4]		C3.15. A80.6V. [P2-3-5],[N1-2-4]		C5. A80.6V. [P2-3-5],[N1-2-4]		C3.15. A80.6V. [P2-3-5],[N1-2-4]		C3.15. 5V. [P2-3-4],[ND.1-3-4]		
	Peso netto	2 Tubi/Pipe	Kg	16,2	16,7	19,8	20,6	26,6	27,6	30,8	32,3	35,5	37,0	39,1	42,6
	Net weight	4 Tubi/Pipe	Kg	17,1	17,6	20,8	21,6	27,7	28,7	32,0	33,5	36,8	38,3	40,5	44,0
FX-P	Ref. FAN-DECK		C3.15. A40.6V. [P2-3-5],[N1-2-4]		C3.15. A80.6V. [P2-3-5],[N1-2-4]		C2. A80.6V. [P2-3-5],[N1-2-4]		C4. A80.6V. [P2-3-5],[N1-2-4]		C4. 6V. [P2-3-4],[N1-3-5]		C4. 5V. [P2-3-4],[N1-3-4]		
	Peso netto	2 Tubi/Pipe	Kg	16,8	17,3	20,6	21,4	27,1	28,1	31,7	33,2	36,6	38,1	40,2	43,7
	Net weight	4 Tubi/Pipe	Kg	17,7	18,2	21,6	22,4	28,2	29,2	32,9	34,4	37,9	39,4	41,6	45,1
FX-S	Ref. FAN-DECK		C1.5. A40.6V. [P4-5-6],[N4-5-6]		C2.5. A40.6V. [P4-5-6],[N4-5-6]		C2.5. A80.6V. [P4-5-6],[N4-5-6]		C4. A80.6V. [P4-5-6],[N4-5-6]		C2.5. A80.6V. [P4-5-6],[N4-5-6]		C4. V3-A240. [P4-5-6],[N4-5-6]		
	Peso netto	2 Tubi/Pipe	Kg	16,9	17,4	20,5	21,3	27,3	28,3	31,5	33,0	36,2	37,7	39,8	43,3
	Net weight	4 Tubi/Pipe	Kg	17,8	18,3	21,5	22,3	28,4	29,4	32,7	34,2	37,5	39,0	41,2	44,7
FXE	Ref. FAN-DECK		SWP/STD.1/10, SWN/STD.1/10		SWP/STD.1/10, SWN/STD.1/10		SWP/STD.1/10, SWN/Pot1.1/10		SWP/STD.1/10, SWN/Pot1D.1/10		SWP/STD.1/10, SWN/Pot1.1/10		SWP/FIX.1/10, SWD/FIXD1.1/10		
	Peso netto	2 Tubi/Pipe	Kg	15,8	16,3	19,9	20,7	27,0	28,0	30,7	32,2	34,6	36,1	38,9	42,4
	Net weight	4 Tubi/Pipe	Kg	16,7	17,2	20,9	21,7	28,1	29,1	31,9	33,4	35,9	37,4	40,3	43,8
FXE-P	Ref. FAN-DECK		SWP/STD.1/10, SWD/STD.1/10		SWP/STD.1/10, SWD/STD.1/10		SWP/Pot1.1/10, SWD/Pot1.1/10		SWP/Pot1.1/10, SWD/Pot1.1/10		SWP/FIX.1/10, SWD/FIX.1/10		SWP/FIX.1/10, SWD/FIXD1.1/10		
	Peso netto	2 Tubi/Pipe	Kg	16,1	16,6	20,2	21,0	27,3	28,3	31,0	32,5	34,9	36,4	39,2	42,7
	Net weight	4 Tubi/Pipe	Kg	17,0	17,5	21,2	22,0	28,4	29,4	32,2	33,7	36,2	37,7	40,6	44,1
FXE-S	Ref. FAN-DECK		SWP/STD.1/7, SWD/STD.1/7		SWP/STD.1/7, SWD/STD.1/7		SWP/STD.1/7, SWD/STD.1/7		SWP/STD.1/8, SWD/STD.1/8		SWP/STD.1/9, SWD/STD.1/9		SWP/FIX.1/10, SWD/FIXD2.1/10		
	Peso netto	2 Tubi/Pipe	Kg	16,8	17,3	20,9	21,7	28,0	29,0	31,7	33,2	35,6	37,1	39,9	43,4
	Net weight	4 Tubi/Pipe	Kg	17,7	18,2	21,9	22,7	28,1	29,1	32,9	34,4	36,9	38,4	41,3	44,8
FXE+	Ref. FAN-DECK		SWP/STD.1/10, SWN/STD.1/10		SWP/STD.1/10, SWN/STD.1/10										
	Peso netto	2 Tubi/Pipe	Kg	16,6	17,1	20,7	21,5	Non disponibile		Non disponibile		Non disponibile		Non disponibile	
	Net weight	4 Tubi/Pipe	Kg	17,5	18,0	21,7	22,5	Not available		Not available		Not available		Not available	

DN(*) = Diametro nominale, F = Attacchi idraulici batteria Gas femmina

DN(*) = Nominal diameter, F = Female gas water coil connections

▪ Peso netto= solo unità, escluso imballo

▪ Net weight= unit only, excluding packaging

Versione Incasso verticale (base; senza mobile) Vertical concealed version (basic; without cabinet)

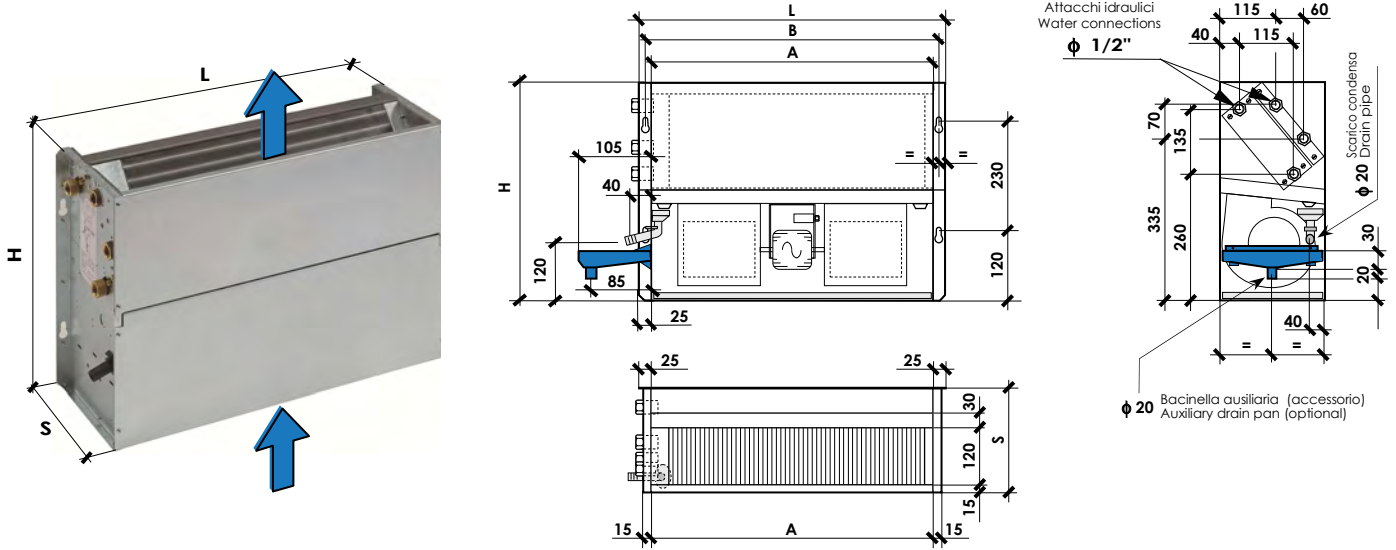

Taglia - Size			DF-X, FXE, ...	100	200	300	400	500	600	700	800	900	1000	1100	1200
Dimensioni principali Main dimensions	L	mm		450	450	650	650	850	850	1050	1050	1250	1250	1450	1450
	H	mm		450	450	450	450	450	450	450	450	450	450	450	450
	S	mm		215	215	215	215	215	215	215	215	215	215	215	215
	A	mm		400	400	600	600	800	800	1.000	1.000	1.200	1.200	1.400	1.400
	B	mm		425	425	625	625	825	825	1.025	1.025	1.225	1.225	1.425	1.425
N° Motori				1	1	1	1	1	1	1	1	1	1	1	1
N° Ventilatori				1	1	1	1	2	2	2	2	2	2	3	3
Batteria caldo/freddo Heating/cooling coil	Contenuto acqua Water volume (l)			0,69	0,70	0,99	1,01	1,30	1,31	1,60	1,62	1,91	1,92	2,21	2,23
	Ranghi - Rows DN(*)			3R 1/2" F	3R 1/2" F	3R 1/2" F	3R 1/2" F	3R 1/2" F	3R 1/2" F	3R 1/2" F	3R 1/2" F	3R 1/2" F	3R 1/2" F	3R 1/2" F	3R 1/2" F
Batteria caldo Heating coil	Contenuto acqua Water volume (l)			0,23	0,23	0,33	0,33	0,43	0,43	0,54	0,54	0,64	0,64	0,74	0,74
	Ranghi - Rows DN(*)			1R 1/2" F	1R 1/2" F	1R 1/2" F	1R 1/2" F	1R 1/2" F	1R 1/2" F	1R 1/2" F	1R 1/2" F	1R 1/2" F	1R 1/2" F	1R 1/2" F	1R 1/2" F
Scarico condensa - Drain pipe			φ(mm)	20	20	20	20	20	20	20	20	20	20	20	20
FX	Ref. FAN-DECK			C2, A40.6V, [P2-3-5],[N1-2-4]		C3.15, A40.6V, [P2-3-5],[N1-2-4]		C3.15, A80.6V, [P2-3-5],[N1-2-4]		C5, A80.6V, [P2-3-5],[N1-2-4]		C3.15, A80.6V, [P2-3-5],[N1-2-4]		C3.15, 5V, [P2-3-4],[ND.1-3-4]	
	Peso netto	2 Tubi/Pipe	Kg	10,7	11,2	13,5	14,3	19,5	20,5	22,9	24,4	26,8	28,3	29,6	33,1
	Net weight	4 Tubi/Pipe	Kg	11,6	12,1	14,5	15,3	20,6	21,6	24,1	25,6	28,1	29,6	31,0	34,5
FX-P	Ref. FAN-DECK			C3.15, A40.6V, [P2-3-5],[N1-2-4]		C3.15, A80.6V, [P2-3-5],[N1-2-4]		C2, A80.6V, [P2-3-5],[N1-2-4]		C4, A80.6V, [P2-3-5],[N1-2-4]		C4, 6V, [P2-3-4],[N1-3-5]		C4, 5V, [P2-3-4],[N1-3-4]	
	Peso netto	2 Tubi/Pipe	Kg	11,3	11,8	14,3	15,1	20,0	21,0	23,8	25,3	27,9	29,4	30,7	34,2
	Net weight	4 Tubi/Pipe	Kg	12,2	12,7	15,3	16,1	21,1	22,1	25,0	26,5	29,2	30,7	32,1	35,6
FX-S	Ref. FAN-DECK			C1.5, A40.6V, [P4-5-6],[N4-5-6]		C2.5, A40.6V, [P4-5-6],[N4-5-6]		C2.5, A80.6V, [P4-5-6],[N4-5-6]		C4, A80.6V, [P4-5-6],[N4-5-6]		C2.5, A80.6V, [P4-5-6],[N4-5-6]		C4, V3-A240, [P4-5-6],[N4-5-6]	
	Peso netto	2 Tubi/Pipe	Kg	11,4	11,9	14,2	15,0	20,2	21,2	23,6	25,1	27,5	29,0	30,3	33,8
	Net weight	4 Tubi/Pipe	Kg	12,3	12,8	15,2	16,0	21,3	22,3	24,8	26,3	28,8	30,3	31,7	35,2
FXE	Ref. FAN-DECK			SWP/STD.1/10, SWN/STD.1/10		SWP/STD.1/10, SWN/STD.1/10		SWP/STD.1/10, SWN/Pot1.D.1/10		SWP/STD.1/10, SWN/Pot1.D.1/10		SWP/STD.1/10, SWN/Pot1.1/10		SWP/RFX.1/10, SWD/RFXD.1/10	
	Peso netto	2 Tubi/Pipe	Kg	10,3	10,8	13,6	14,4	19,9	20,9	22,8	24,3	25,9	27,4	29,4	32,9
	Net weight	4 Tubi/Pipe	Kg	11,2	11,7	14,6	15,4	21,0	22,0	24,0	25,5	27,2	28,7	30,8	34,3
FXE-P	Ref. FAN-DECK			SWP/STD.1/10, SWD/STD.1/10		SWP/STD.1/10, SWD/STD.1/10		SWP/Pot1.1/10, SWD/Pot1.1/10		SWP/Pot1.1/10, SWD/Pot1.1/10		SWP/RFX.1/10, SWD/RFX.1/10		SWP/RFX.1/10, SWD/RFXD.1/10	
	Peso netto	2 Tubi/Pipe	Kg	10,6	11,1	13,9	14,7	20,2	21,2	23,1	24,6	26,2	27,7	29,7	33,2
	Net weight	4 Tubi/Pipe	Kg	11,5	12,0	14,9	15,7	21,3	22,3	24,3	25,8	27,5	29,0	31,1	34,6
FXE-S	Ref. FAN-DECK			SWP/STD.1/7, SWD/STD.1/7		SWP/STD.1/7, SWD/STD.1/7		SWP/STD.1/7, SWD/STD.1/7		SWP/STD.1/8, SWD/STD.1/8		SWP/STD.1/9, SWD/STD.1/9		SWP/RFX.1/10, SWD/RFXD.2.1/10	
	Peso netto	2 Tubi/Pipe	Kg	11,3	11,8	14,6	15,4	20,9	21,9	23,8	25,3	26,9	28,4	30,4	33,9
	Net weight	4 Tubi/Pipe	Kg	12,2	12,7	15,6	16,4	22,0	23,0	25,0	26,5	28,2	29,7	31,8	35,3
FXE+	Ref. FAN-DECK			SWP/STD.1/10, SWN/STD.1/10		SWP/STD.1/10, SWN/STD.1/10									
	Peso netto	2 Tubi/Pipe	Kg	11,1	11,6	14,4	15,2	Non disponibile		Non disponibile		Non disponibile		Non disponibile	
	Net weight	4 Tubi/Pipe	Kg	12,0	12,5	15,4	16,2	Not available		Not available		Not available		Not available	

DN(*) = Diametro nominale, F = Attacchi idraulici batteria Gas femmina

DN(*) = Nominal diameter, F = Female gas water coil connections

• Peso netto= solo unità, escluso imballo

• Net weight= unit only, excluding packaging

FX-CB

Versione incasso verticale (aspirazione aria frontale; senza mobile) Vertical concealed version (front air intake; without cabinet)

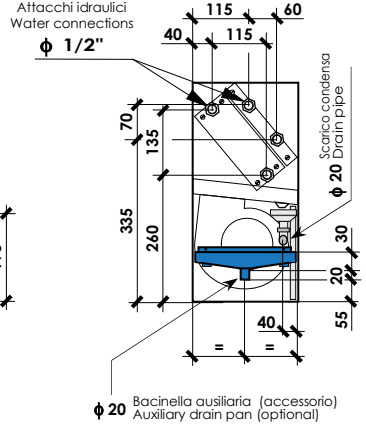
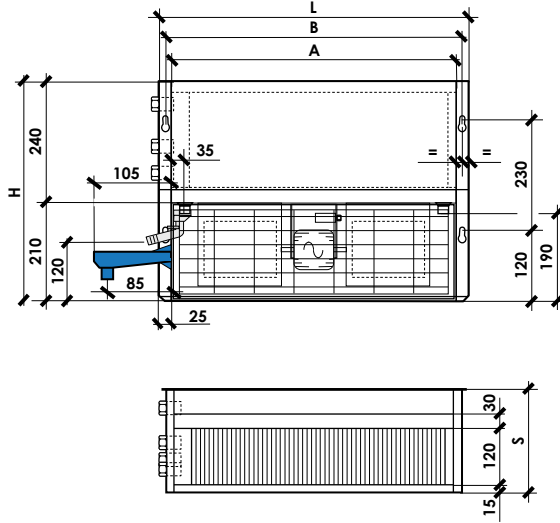
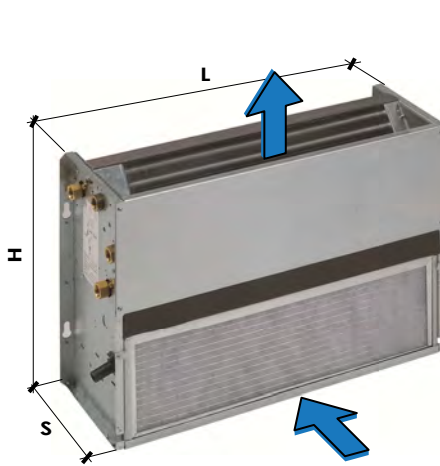

Taglia - Size			DF-X, FXE, ...	100	200	300	400	500	600	700	800	900	1000	1100	1200
Dimensioni principali Main dimensions	L	mm		450	450	650	650	850	850	1050	1050	1250	1250	1450	1450
	H	mm		450	450	450	450	450	450	450	450	450	450	450	450
	S	mm		215	215	215	215	215	215	215	215	215	215	215	215
	A	mm		400	400	600	600	800	800	1.000	1.000	1.200	1.200	1.400	1.400
	B	mm		425	425	625	625	825	825	1.025	1.025	1.225	1.225	1.425	1.425
N° Motori				1	1	1	1	1	1	1	1	1	1	1	1
N° Ventilatori				1	1	1	1	2	2	2	2	2	2	3	3
Batteria caldo/freddo Heating/cooling coil	Contenuto acqua Water volume (l)			0,69	0,70	0,99	1,01	1,30	1,31	1,60	1,62	1,91	1,92	2,21	2,23
	Ranghi - Rows DN(*)			3R 1/2" F	3R 1/2" F	3R 1/2" F	3R 1/2" F	3R 1/2" F	3R 1/2" F	3R 1/2" F	3R 1/2" F	3R 1/2" F	3R 1/2" F	3R 1/2" F	3R 1/2" F
Batteria caldo Heating coil	Contenuto acqua Water volume (l)			0,23	0,23	0,33	0,33	0,43	0,43	0,54	0,54	0,64	0,64	0,74	0,74
	Ranghi - Rows DN(*)			1R 1/2" F	1R 1/2" F	1R 1/2" F	1R 1/2" F	1R 1/2" F	1R 1/2" F	1R 1/2" F	1R 1/2" F	1R 1/2" F	1R 1/2" F	1R 1/2" F	1R 1/2" F
Scarico condensa - Drain pipe			φ(mm)	20	20	20	20	20	20	20	20	20	20	20	20
FX	Ref. FAN-DECK			C2, A40.6V, [P2-3-5],[N1-2-4]	C3.15, A40.6V, [P2-3-5],[N1-2-4]	C3.15, A40.6V, [P2-3-5],[N1-2-4]	C3.15, A40.6V, [P2-3-5],[N1-2-4]	C3.15, A80.6V, [P2-3-5],[N1-2-4]	C3.15, A80.6V, [P2-3-5],[N1-2-4]	C5, A80.6V, [P2-3-5],[N1-2-4]	C5, A80.6V, [P2-3-5],[N1-2-4]	C3.15, A80.6V, [P2-3-5],[N1-2-4]	C3.15, A80.6V, [P2-3-5],[N1-2-4]	C3.15, 5V, [P2-3-4],[ND.1-3-4]	C3.15, 5V, [P2-3-4],[ND.1-3-4]
	Peso netto	2 Tubi/Pipe	Kg	10,6	11,1	13,4	14,2	19,4	20,4	22,7	24,2	26,6	28,1	29,4	32,9
	Net weight	4 Tubi/Pipe	Kg	11,5	12,0	14,4	15,2	20,5	21,5	23,9	25,4	27,9	29,4	30,8	34,3
FX-P	Ref. FAN-DECK			C3.15, A40.6V, [P2-3-5],[N1-2-4]	C3.15, A80.6V, [P2-3-5],[N1-2-4]	C3.15, A80.6V, [P2-3-5],[N1-2-4]	C2, A80.6V, [P2-3-5],[N1-2-4]	C2, A80.6V, [P2-3-5],[N1-2-4]	C4, A80.6V, [P2-3-5],[N1-2-4]	C4, A80.6V, [P2-3-5],[N1-2-4]	C4, 6V, [P2-3-4],[N1-3-5]	C4, 6V, [P2-3-4],[N1-3-5]	C4, 5V, [P2-3-4],[N1-3-4]	C4, 5V, [P2-3-4],[N1-3-4]	
	Peso netto	2 Tubi/Pipe	Kg	11,2	11,7	14,2	15,0	19,9	20,9	23,6	25,1	27,7	29,2	30,5	34,0
	Net weight	4 Tubi/Pipe	Kg	12,1	12,6	15,2	16,0	21,0	22,0	24,8	26,3	29,0	30,5	31,9	35,4
FX-S	Ref. FAN-DECK			C1.5, A40.6V, [P4-5-6],[N4-5-6]	C2.5, A40.6V, [P4-5-6],[N4-5-6]	C2.5, A40.6V, [P4-5-6],[N4-5-6]	C2.5, A40.6V, [P4-5-6],[N4-5-6]	C2.5, A80.6V, [P4-5-6],[N4-5-6]	C2.5, A80.6V, [P4-5-6],[N4-5-6]	C4, A80.6V, [P4-5-6],[N4-5-6]	C4, A80.6V, [P4-5-6],[N4-5-6]	C2.5, A80.6V, [P4-5-6],[N4-5-6]	C2.5, A80.6V, [P4-5-6],[N4-5-6]	C4, V3-A240, [P4-5-6],[N4-5-6]	C4, V3-A240, [P4-5-6],[N4-5-6]
	Peso netto	2 Tubi/Pipe	Kg	11,3	11,8	14,1	14,9	20,1	21,1	23,4	24,9	27,3	28,8	30,1	33,6
	Net weight	4 Tubi/Pipe	Kg	12,2	12,7	15,1	15,9	21,2	22,2	24,6	26,1	28,6	30,1	31,5	35,0
FXE	Ref. FAN-DECK			SWP/STD.1/10, SWN/STD.1/10	SWP/STD.1/10, SWN/STD.1/10	SWP/STD.1/10, SWN/STD.1/10	SWP/STD.1/10, SWN/STD.1/10	SWP/STD.1/10, SWN/StdD.1/10	SWP/STD.1/10, SWN/StdD.1/10	SWP/STD.1/10, SWN/StdD.1/10	SWP/STD.1/10, SWN/StdD.1/10	SWP/STD.1/10, SWN/StdD.1/10	SWP/STD.1/10, SWN/StdD.1/10	SWP/STD.1/10, SWN/StdD.1/10	SWP/STD.1/10, SWN/StdD.1/10
	Peso netto	2 Tubi/Pipe	Kg	10,2	10,7	13,5	14,3	19,8	20,8	22,6	24,1	25,7	27,2	29,2	32,7
	Net weight	4 Tubi/Pipe	Kg	11,1	11,6	14,5	15,3	20,9	21,9	23,8	25,3	27,0	28,5	30,6	34,1
FXE-P	Ref. FAN-DECK			SWP/STD.1/10, SWD/STD.1/10	SWP/STD.1/10, SWD/STD.1/10	SWP/STD.1/10, SWD/STD.1/10	SWP/STD.1/10, SWD/STD.1/10	SWP/StdD.1/10, SWD/StdD.1/10	SWP/StdD.1/10, SWD/StdD.1/10	SWP/StdD.1/10, SWD/StdD.1/10	SWP/StdD.1/10, SWD/StdD.1/10	SWP/StdD.1/10, SWD/StdD.1/10	SWP/StdD.1/10, SWD/StdD.1/10	SWP/StdD.1/10, SWD/StdD.1/10	SWP/StdD.1/10, SWD/StdD.1/10
	Peso netto	2 Tubi/Pipe	Kg	10,5	11,0	13,8	14,6	20,1	21,1	22,9	24,4	26,0	27,5	29,5	33,0
	Net weight	4 Tubi/Pipe	Kg	11,4	11,9	14,8	15,6	21,2	22,2	24,1	25,6	27,3	28,8	30,9	34,4
FXE-S	Ref. FAN-DECK			SWP/STD.1/7, SWD/STD.1/7	SWP/STD.1/7, SWD/STD.1/7	SWP/STD.1/7, SWD/STD.1/7	SWP/STD.1/7, SWD/STD.1/7	SWP/STD.1/7, SWD/STD.1/7	SWP/STD.1/7, SWD/STD.1/7	SWP/STD.1/8, SWD/STD.1/8	SWP/STD.1/8, SWD/STD.1/8	SWP/STD.1/9, SWD/STD.1/9	SWP/STD.1/9, SWD/STD.1/9	SWP/StdD.1/10, SWD/StdD.1/10	SWP/StdD.1/10, SWD/StdD.1/10
	Peso netto	2 Tubi/Pipe	Kg	11,2	11,7	14,5	15,3	20,8	21,8	23,6	25,1	26,7	28,2	30,2	33,7
	Net weight	4 Tubi/Pipe	Kg	12,1	12,6	15,5	16,3	21,9	22,9	24,8	26,3	28,0	29,5	31,6	35,1
FXE+	Ref. FAN-DECK			SWP/STD.1/10, SWN/STD.1/10	SWP/STD.1/10, SWN/STD.1/10	SWP/STD.1/10, SWN/STD.1/10	SWP/STD.1/10, SWN/STD.1/10	Non disponibile	Non disponibile	Non disponibile	Non disponibile	Non disponibile	Non disponibile	Non disponibile	Non disponibile
	Peso netto	2 Tubi/Pipe	Kg	11,0	11,5	14,3	15,1	Non disponibile	Non disponibile	Non disponibile	Non disponibile	Non disponibile	Non disponibile	Non disponibile	Non disponibile
	Net weight	4 Tubi/Pipe	Kg	11,9	12,4	15,3	16,1	Non disponibile	Non disponibile	Non disponibile	Non disponibile	Non disponibile	Non disponibile	Non disponibile	Non disponibile

DN(*) = Diametro nominale, F = Attacchi idraulici batteria Gas femmina

DN(*) = Nominal diameter, F = Female gas water coil connections

• Peso netto= solo unità, escluso imballo

• Net weight= unit only, excluding packaging

Versione incasso verticale (mandata aria frontale; senza mobile) Vertical concealed version (front air supply; without cabinet)

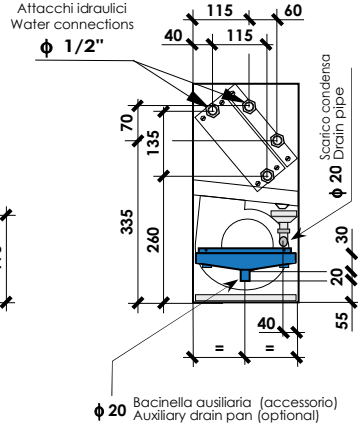
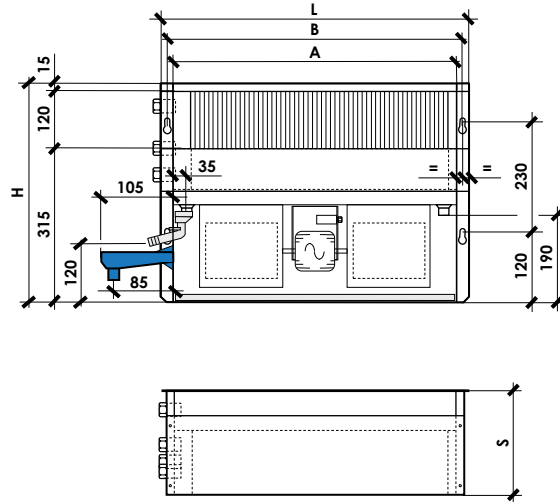
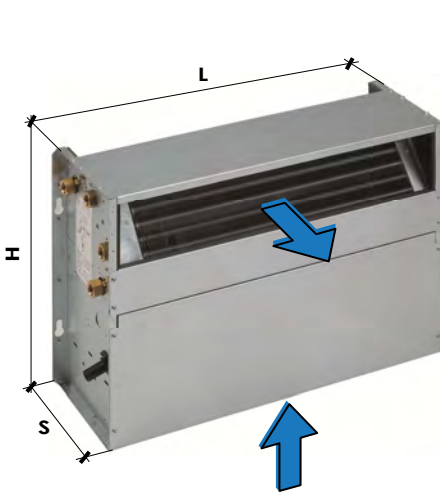

Taglia - Size			DF-X, FXE, ...	100	200	300	400	500	600	700	800	900	1000	1100	1200
Dimensioni principali Main dimensions	L	mm		450	450	650	650	850	850	1050	1050	1250	1250	1450	1450
	H	mm		450	450	450	450	450	450	450	450	450	450	450	450
	S	mm		215	215	215	215	215	215	215	215	215	215	215	215
	A	mm		400	400	600	600	800	800	1.000	1.000	1.200	1.200	1.400	1.400
	B	mm		425	425	625	625	825	825	1.025	1.025	1.225	1.225	1.425	1.425
N° Motori				1	1	1	1	1	1	1	1	1	1	1	1
N° Ventilatori				1	1	1	1	2	2	2	2	2	2	3	3
Batteria caldo/freddo Heating/cooling coil	Contenuto acqua Water volume (l)			0,69	0,70	0,99	1,01	1,30	1,31	1,60	1,62	1,91	1,92	2,21	2,23
	Ranghi - Rows DN(*)			3R 1/2" F	3R 1/2" F	3R 1/2" F	3R 1/2" F	3R 1/2" F	3R 1/2" F	3R 1/2" F	3R 1/2" F	3R 1/2" F	3R 1/2" F	3R 1/2" F	3R 1/2" F
Batteria caldo Heating coil	Contenuto acqua Water volume (l)			0,23	0,23	0,33	0,33	0,43	0,43	0,54	0,54	0,64	0,64	0,74	0,74
	Ranghi - Rows DN(*)			1R 1/2" F	1R 1/2" F	1R 1/2" F	1R 1/2" F	1R 1/2" F	1R 1/2" F	1R 1/2" F	1R 1/2" F	1R 1/2" F	1R 1/2" F	1R 1/2" F	1R 1/2" F
Scarico condensa - Drain pipe			φ(mm)	20	20	20	20	20	20	20	20	20	20	20	20
FX	Ref. FAN-DECK			C2, A40.6V, [P2-3-5],[N1-2-4]		C3.15, A40.6V, [P2-3-5],[N1-2-4]		C3.15, A80.6V, [P2-3-5],[N1-2-4]		C5, A80.6V, [P2-3-5],[N1-2-4]		C3.15, A80.6V, [P2-3-5],[N1-2-4]		C3.15, 5V, [P2-3-4],[ND.1-3-4]	
	Peso netto	2 Tubi/Pipe	Kg	11,1	11,6	14,1	14,9	20,3	21,3	23,9	25,4	28,0	29,5	31,0	34,5
	Net weight	4 Tubi/Pipe	Kg	12,0	12,5	15,1	15,9	21,4	22,4	25,1	26,6	29,3	30,8	32,4	35,9
FX-P	Ref. FAN-DECK			C3.15, A40.6V, [P2-3-5],[N1-2-4]		C3.15, A80.6V, [P2-3-5],[N1-2-4]		C2, A80.6V, [P2-3-5],[N1-2-4]		C4, A80.6V, [P2-3-5],[N1-2-4]		C4, 6V, [P2-3-4],[N1-3-5]		C4, 5V, [P2-3-4],[N1-3-4]	
	Peso netto	2 Tubi/Pipe	Kg	11,7	12,2	14,9	15,7	20,8	21,8	24,8	26,3	29,1	30,6	32,1	35,6
	Net weight	4 Tubi/Pipe	Kg	12,6	13,1	15,9	16,7	21,9	22,9	26,0	27,5	30,4	31,9	33,5	37,0
FX-S	Ref. FAN-DECK			C1.5, A40.6V, [P4-5-6],[N4-5-6]		C2.5, A40.6V, [P4-5-6],[N4-5-6]		C2.5, A80.6V, [P4-5-6],[N4-5-6]		C4, A80.6V, [P4-5-6],[N4-5-6]		C2.5, A80.6V, [P4-5-6],[N4-5-6]		C4, V3-A240, [P4-5-6],[N4-5-6]	
	Peso netto	2 Tubi/Pipe	Kg	11,8	12,3	14,8	15,6	21,0	22,0	24,6	26,1	28,7	30,2	31,7	35,2
	Net weight	4 Tubi/Pipe	Kg	12,7	13,2	15,8	16,6	22,1	23,1	25,8	27,3	30,0	31,5	33,1	36,6
FXE	Ref. FAN-DECK			SWP/STD.1/10, SWN/STD.1/10		SWP/STD.1/10, SWN/STD.1/10		SWP/STD.1/10, SWN/Pot1.D.1/10		SWP/STD.1/10, SWN/Pot1.D.1/10		SWP/STD.1/10, SWN/Pot1.1/10		SWP/RFX.1/10, SWD/RXD1.1/10	
	Peso netto	2 Tubi/Pipe	Kg	10,7	11,2	14,2	15,0	20,7	21,7	23,8	25,3	27,1	28,6	30,8	34,3
	Net weight	4 Tubi/Pipe	Kg	11,6	12,1	15,2	16,0	21,8	22,8	25,0	26,5	28,4	29,9	32,2	35,7
FXE-P	Ref. FAN-DECK			SWP/STD.1/10, SWD/STD.1/10		SWP/STD.1/10, SWD/STD.1/10		SWP/Pot1.1/10, SWD/Pot1.1/10		SWP/Pot1.1/10, SWD/Pot1.1/10		SWP/RFX.1/10, SWD/RFX.1/10		SWP/RFX.1/10, SWD/RXD1.1/10	
	Peso netto	2 Tubi/Pipe	Kg	11,0	11,5	14,5	15,3	21,0	22,0	24,1	25,6	27,4	28,9	31,1	34,6
	Net weight	4 Tubi/Pipe	Kg	11,9	12,4	15,5	16,3	22,1	23,1	25,3	26,8	28,7	30,2	32,5	36,0
FXE-S	Ref. FAN-DECK			SWP/STD.1/7, SWD/STD.1/7		SWP/STD.1/7, SWD/STD.1/7		SWP/STD.1/7, SWD/STD.1/7		SWP/STD.1/8, SWD/STD.1/8		SWP/STD.1/9, SWD/STD.1/9		SWP/RFX.1/10, SWD/RXD2.1/10	
	Peso netto	2 Tubi/Pipe	Kg	11,7	12,2	15,2	16,0	21,7	22,7	24,8	26,3	28,1	29,6	31,8	35,3
	Net weight	4 Tubi/Pipe	Kg	12,6	13,1	16,2	17,0	22,8	23,8	26,0	27,5	29,4	30,9	33,2	36,7
FXE+	Ref. FAN-DECK			SWP/STD.1/10, SWN/STD.1/10		SWP/STD.1/10, SWN/STD.1/10									
	Peso netto	2 Tubi/Pipe	Kg	11,5	12,0	15,0	15,8	Non disponibile		Non disponibile		Non disponibile		Non disponibile	
	Net weight	4 Tubi/Pipe	Kg	12,4	12,9	16,0	16,8	Not available		Not available		Not available		Not available	

DN(*) = Diametro nominale, F = Attacchi idraulici batteria Gas femmina

DN(*) = Nominal diameter, F = Female gas water coil connections

• Peso netto= solo unità, escluso imballo

• Net weight= unit only, excluding packaging

Versione incasso verticale (aspirazione e mandata aria frontali; senza mobile) Vertical concealed version (front air intake and supply; without cabinet)

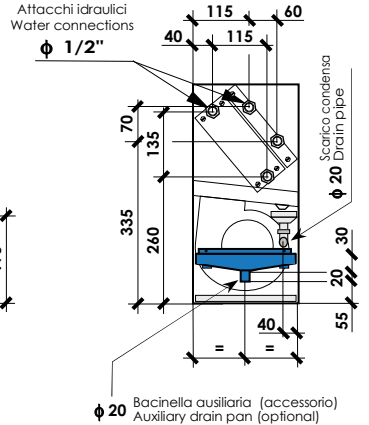
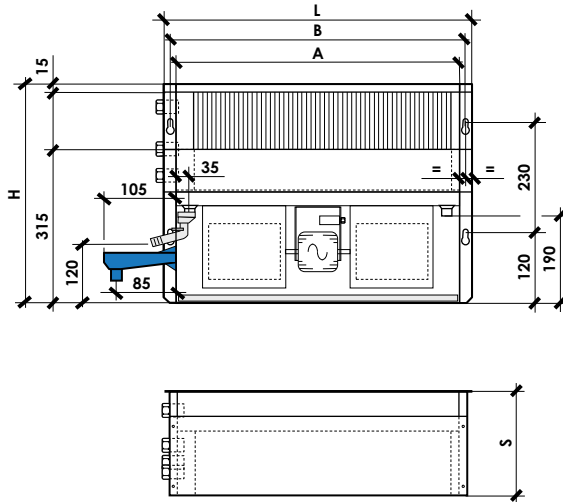
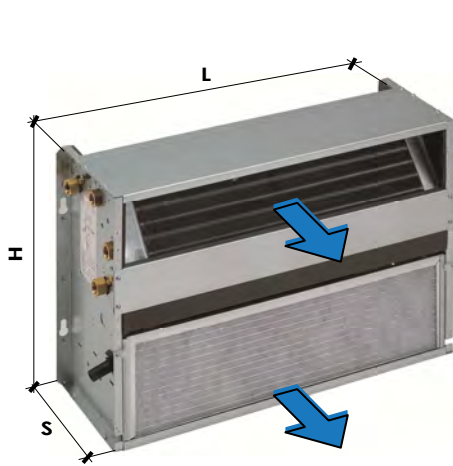

Taglia - Size			DF-X, FXE, ...	100	200	300	400	500	600	700	800	900	1000	1100	1200
Dimensioni principali Main dimensions	L	mm		450	450	650	650	850	850	1050	1050	1250	1250	1450	1450
	H	mm		450	450	450	450	450	450	450	450	450	450	450	450
	S	mm		215	215	215	215	215	215	215	215	215	215	215	215
	A	mm		400	400	600	600	800	800	1.000	1.000	1.200	1.200	1.400	1.400
	B	mm		425	425	625	625	825	825	1.025	1.025	1.225	1.225	1.425	1.425
N° Motori N° Ventilatori				1	1	1	1	1	1	1	1	1	1	1	1
Batteria caldo/freddo Heating/cooling coil	Contenuto acqua Water volume (l)			0,69	0,70	0,99	1,01	1,30	1,31	1,60	1,62	1,91	1,92	2,21	2,23
	Ranghi - Rows DN(*)			3R 1/2" F	3R 1/2" F	3R 1/2" F	3R 1/2" F	3R 1/2" F	3R 1/2" F	3R 1/2" F	3R 1/2" F	3R 1/2" F	3R 1/2" F	3R 1/2" F	3R 1/2" F
Batteria caldo Heating coil	Contenuto acqua Water volume (l)			0,23	0,23	0,33	0,33	0,43	0,43	0,54	0,54	0,64	0,64	0,74	0,74
	Ranghi - Rows DN(*)			1R 1/2" F	1R 1/2" F	1R 1/2" F	1R 1/2" F	1R 1/2" F	1R 1/2" F	1R 1/2" F	1R 1/2" F	1R 1/2" F	1R 1/2" F	1R 1/2" F	1R 1/2" F
Scarico condensa - Drain pipe			φ(mm)	20	20	20	20	20	20	20	20	20	20	20	20
FX	Ref. FAN-DECK			C2, A40.6V, [P2-3-5],[N1-2-4]		C3.15, A40.6V, [P2-3-5],[N1-2-4]		C3.15, A80.6V, [P2-3-5],[N1-2-4]		C5, A80.6V, [P2-3-5],[N1-2-4]		C3.15, A80.6V, [P2-3-5],[N1-2-4]		C3.15, 5V, [P2-3-4],[ND.1-3-4]	
	Peso netto	2 Tubi/Pipe	Kg	11,0	11,5	14,0	14,8	20,2	21,2	23,7	25,2	27,8	29,3	30,8	34,3
	Net weight	4 Tubi/Pipe	Kg	11,9	12,4	15,0	15,8	21,3	22,3	24,9	26,4	29,1	30,6	32,2	35,7
FX-P	Ref. FAN-DECK			C3.15, A40.6V, [P2-3-5],[N1-2-4]		C3.15, A80.6V, [P2-3-5],[N1-2-4]		C2, A80.6V, [P2-3-5],[N1-2-4]		C4, A80.6V, [P2-3-5],[N1-2-4]		C4, 6V, [P2-3-4],[N1-3-5]		C4, 5V, [P2-3-4],[N1-3-4]	
	Peso netto	2 Tubi/Pipe	Kg	11,6	12,1	14,8	15,6	20,7	21,7	24,6	26,1	28,9	30,4	31,9	35,4
	Net weight	4 Tubi/Pipe	Kg	12,5	13,0	15,8	16,6	21,8	22,8	25,8	27,3	30,2	31,7	33,3	36,8
FX-S	Ref. FAN-DECK			C1.5, A40.6V, [P4-5-6],[N4-5-6]		C2.5, A40.6V, [P4-5-6],[N4-5-6]		C2.5, A80.6V, [P4-5-6],[N4-5-6]		C4, A80.6V, [P4-5-6],[N4-5-6]		C2.5, A80.6V, [P4-5-6],[N4-5-6]		C4, V3-A240, [P4-5-6],[N4-5-6]	
	Peso netto	2 Tubi/Pipe	Kg	11,7	12,2	14,7	15,5	20,9	21,9	24,4	25,9	28,5	30,0	31,5	35,0
	Net weight	4 Tubi/Pipe	Kg	12,6	13,1	15,7	16,5	22,0	23,0	25,6	27,1	29,8	31,3	31,9	36,4
FXE	Ref. FAN-DECK			SWP/STD.1/10, SWN/STD.1/10		SWP/STD.1/10, SWN/STD.1/10		SWP/STD.1/10, SWN/Pot1.D.1/10		SWP/STD.1/10, SWN/Pot1.D.1/10		SWP/STD.1/10, SWN/Pot1.1/10		SWP/STD.1/10, SWD/STD.1/10	
	Peso netto	2 Tubi/Pipe	Kg	10,6	11,1	14,1	14,9	20,6	21,6	23,6	25,1	26,9	28,4	30,6	34,1
	Net weight	4 Tubi/Pipe	Kg	11,5	12,0	15,1	15,9	21,7	22,7	24,8	26,3	28,2	29,7	32,0	35,5
FXE-P	Ref. FAN-DECK			SWP/STD.1/10, SWD/STD.1/10		SWP/STD.1/10, SWD/STD.1/10		SWP/Pot1.1/10, SWD/Pot1.1/10		SWP/Pot1.1/10, SWD/Pot1.1/10		SWP/FIX.1/10, SWD/FIX.1/10		SWP/FIX.1/10, SWD/FIX.1/10	
	Peso netto	2 Tubi/Pipe	Kg	10,9	11,4	14,4	15,2	20,9	21,9	23,9	25,4	27,2	28,7	30,9	34,4
	Net weight	4 Tubi/Pipe	Kg	11,8	12,3	15,4	16,2	22,0	23,0	25,1	26,6	28,5	30,0	32,3	35,8
FXE-S	Ref. FAN-DECK			SWP/STD.1/7, SWD/STD.1/7		SWP/STD.1/7, SWD/STD.1/7		SWP/STD.1/7, SWD/STD.1/7		SWP/STD.1/8, SWD/STD.1/8		SWP/STD.1/9, SWD/STD.1/9		SWP/FIX.1/10, SWD/FIX.1/10	
	Peso netto	2 Tubi/Pipe	Kg	11,6	12,1	15,1	15,9	21,6	22,6	24,6	26,1	27,9	29,4	31,6	35,1
	Net weight	4 Tubi/Pipe	Kg	12,5	13,0	16,1	16,9	22,7	23,7	25,8	27,3	29,2	30,7	33,0	36,5
FXE+	Ref. FAN-DECK			SWP/STD.1/10, SWN/STD.1/10		SWP/STD.1/10, SWN/STD.1/10		Non disponibile Not available		Non disponibile Not available		Non disponibile Not available		Non disponibile Not available	
	Peso netto	2 Tubi/Pipe	Kg	11,4	11,9	14,9	15,7								
	Net weight	4 Tubi/Pipe	Kg	12,3	12,8	15,8	16,6								

DN(*) = Diametro nominale, F = Attacchi idraulici batteria Gas femmina

DN(*) = Nominal diameter, F = Female gas water coil connections

• Peso netto= solo unità, escluso imballo

• Net weight= unit only, excluding packaging

Versione incasso orizzontale (base; senza mobile) Horizontal concealed version (basic; without cabinet)

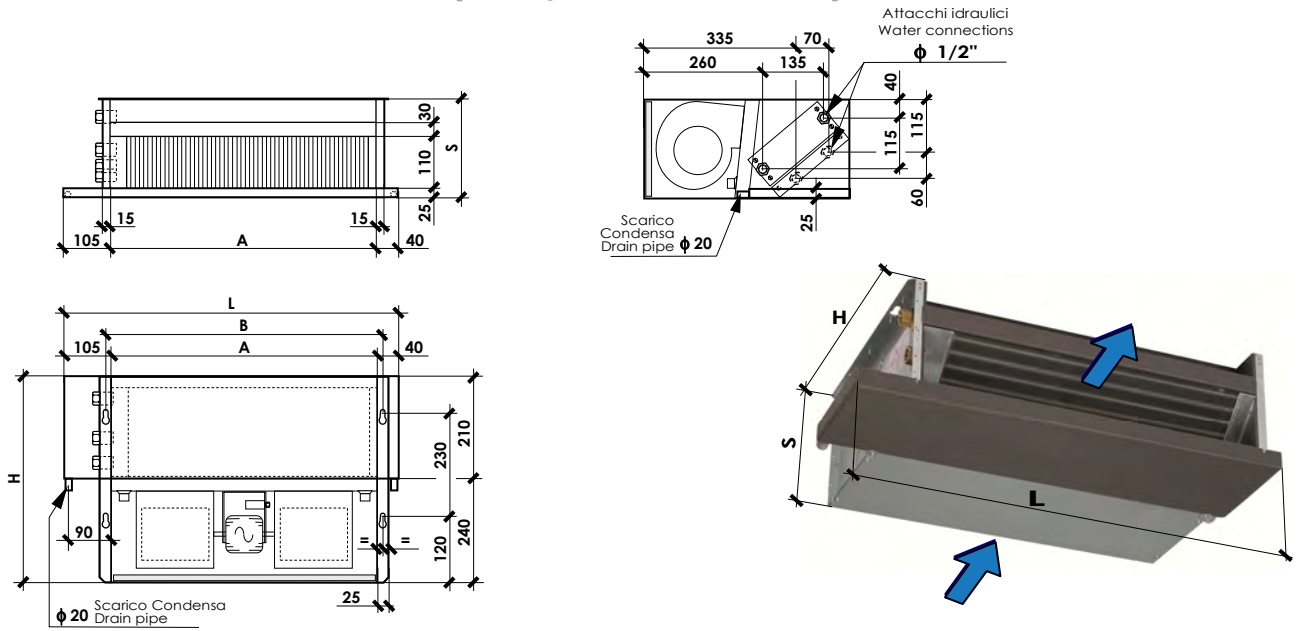

Taglia - Size			DF-X, FXE, ...	100	200	300	400	500	600	700	800	900	1000	1100	1200
Dimensioni principali Main dimensions	L	mm		545	545	745	745	945	945	1145	1145	1345	1345	1545	1545
	H	mm		450	450	450	450	450	450	450	450	450	450	450	450
	S	mm		215	215	215	215	215	215	215	215	215	215	215	215
	A	mm		400	400	600	600	800	800	1.000	1.000	1.200	1.200	1.400	1.400
	B	mm		425	425	625	625	825	825	1.025	1.025	1.225	1.225	1.425	1.425
N° Motori				1	1	1	1	1	1	1	1	1	1	1	1
N° Ventilatori				1	1	1	1	2	2	2	2	2	2	3	3
Batteria caldo/freddo Heating/cooling coil	Contenuto acqua Water volume (l)			0,69	0,70	0,99	1,01	1,30	1,31	1,60	1,62	1,91	1,92	2,21	2,23
	Ranghi - Rows DN(*)			3R 1/2" F	3R 1/2" F	3R 1/2" F	3R 1/2" F	3R 1/2" F	3R 1/2" F	3R 1/2" F	3R 1/2" F	3R 1/2" F	3R 1/2" F	3R 1/2" F	3R 1/2" F
Batteria caldo Heating coil	Contenuto acqua Water volume (l)			0,23	0,23	0,33	0,33	0,43	0,43	0,54	0,54	0,64	0,64	0,74	0,74
	Ranghi - Rows DN(*)			1R 1/2" F	1R 1/2" F	1R 1/2" F	1R 1/2" F	1R 1/2" F	1R 1/2" F	1R 1/2" F	1R 1/2" F	1R 1/2" F	1R 1/2" F	1R 1/2" F	1R 1/2" F
Scarico condensa - Drain pipe			φ(mm)	20	20	20	20	20	20	20	20	20	20	20	20
FX	Ref. FAN-DECK			C2, A40.6V, [P2-3-5],[N1-2-4]		C3.15, A40.6V, [P2-3-5],[N1-2-4]		C3.15, A80.6V, [P2-3-5],[N1-2-4]		C5, A80.6V, [P2-3-5],[N1-2-4]		C3.15, A80.6V, [P2-3-5],[N1-2-4]		C3.15, 5V, [P2-3-4],[ND1-3-4]	
	Peso netto	2 Tubi/Pipe	Kg	11,1	11,6	13,9	14,7	19,9	20,9	23,3	24,8	27,2	28,7	30,0	33,5
	Net weight	4 Tubi/Pipe	Kg	12,0	12,5	14,9	15,7	21,0	22,0	24,5	26,0	28,5	30,0	31,4	34,9
FX-P	Ref. FAN-DECK			C3.15, A40.6V, [P2-3-5],[N1-2-4]		C3.15, A80.6V, [P2-3-5],[N1-2-4]		C2, A80.6V, [P2-3-5],[N1-2-4]		C4, A80.6V, [P2-3-5],[N1-2-4]		C4, 6V, [P2-3-4],[N1-3-5]		C4, 5V, [P2-3-4],[N1-3-4]	
	Peso netto	2 Tubi/Pipe	Kg	11,7	12,2	14,7	15,5	20,4	21,4	24,2	25,7	28,3	29,8	31,1	34,6
	Net weight	4 Tubi/Pipe	Kg	12,6	13,1	15,7	16,5	21,5	22,5	25,4	26,9	29,6	31,1	32,5	36,0
FX-S	Ref. FAN-DECK			C1.5, A40.6V, [P4-5-6],[N4-5-6]		C2.5, A40.6V, [P4-5-6],[N4-5-6]		C2.5, A80.6V, [P4-5-6],[N4-5-6]		C4, A80.6V, [P4-5-6],[N4-5-6]		C2.5, A80.6V, [P4-5-6],[N4-5-6]		C4, V3-A240, [P4-5-6],[N4-5-6]	
	Peso netto	2 Tubi/Pipe	Kg	11,8	12,3	14,6	15,4	20,6	21,6	24,0	25,5	27,9	29,4	30,7	34,2
	Net weight	4 Tubi/Pipe	Kg	12,7	13,2	15,6	16,4	21,7	22,7	25,2	26,7	29,2	30,7	32,1	35,6
FXE	Ref. FAN-DECK			SWP/STD.1/10, SWN/STD.1/10		SWP/STD.1/10, SWN/STD.1/10		SWP/STD.1/10, SWN/Pot1.D.1/10		SWP/STD.1/10, SWN/Pot1.D.1/10		SWP/STD.1/10, SWN/Pot1.1/10		SWP/RFX.1/10, SWD/RFXD.1/10	
	Peso netto	2 Tubi/Pipe	Kg	10,7	11,2	14,0	14,8	20,3	21,3	23,2	24,7	26,3	27,8	29,8	33,3
	Net weight	4 Tubi/Pipe	Kg	11,6	12,1	15,0	15,8	21,4	22,4	24,4	25,9	27,6	29,1	31,2	34,7
FXE-P	Ref. FAN-DECK			SWP/STD.1/10, SWD/STD.1/10		SWP/STD.1/10, SWD/STD.1/10		SWP/Pot1.1/10, SWD/Pot1.1/10		SWP/Pot1.1/10, SWD/Pot1.1/10		SWP/RFX.1/10, SWD/RFX.1/10		SWP/RFX.1/10, SWD/RFXD.1/10	
	Peso netto	2 Tubi/Pipe	Kg	11,0	11,5	14,3	15,1	20,6	21,6	23,5	25,0	26,6	28,1	30,1	33,6
	Net weight	4 Tubi/Pipe	Kg	11,9	12,4	15,3	16,1	21,7	22,7	24,7	26,2	27,9	29,4	31,5	35,0
FXE-S	Ref. FAN-DECK			SWP/STD.1/7, SWD/STD.1/7		SWP/STD.1/7, SWD/STD.1/7		SWP/STD.1/7, SWD/STD.1/7		SWP/STD.1/8, SWD/STD.1/8		SWP/STD.1/9, SWD/STD.1/9		SWP/RFX.1/10, SWD/RFXD.1/10	
	Peso netto	2 Tubi/Pipe	Kg	11,7	12,2	15,0	15,8	21,3	22,3	24,2	25,7	27,3	28,8	30,8	34,3
	Net weight	4 Tubi/Pipe	Kg	12,6	13,1	16,0	16,8	22,4	23,4	25,4	26,9	28,6	30,1	32,2	35,7
FXE+	Ref. FAN-DECK			SWP/STD.1/10, SWN/STD.1/10		SWP/STD.1/10, SWN/STD.1/10		Non disponibile Not available		Non disponibile Not available		Non disponibile Not available		Non disponibile Not available	
	Peso netto	2 Tubi/Pipe	Kg	11,5	12,0	14,8	15,6								
	Net weight	4 Tubi/Pipe	Kg	12,4	12,9	15,8	16,6								

DN(*) = Diametro nominale, F = Attacchi idraulici batteria Gas femmina

DN(*) = Nominal diameter, F = Female gas water coil connections

• Peso netto= solo unità, escluso imballo

• Net weight= unit only, excluding packaging

Versione incasso orizzontale (aspirazione aria frontale; senza mobile) Horizontal concealed version (front air intake; without cabinet)

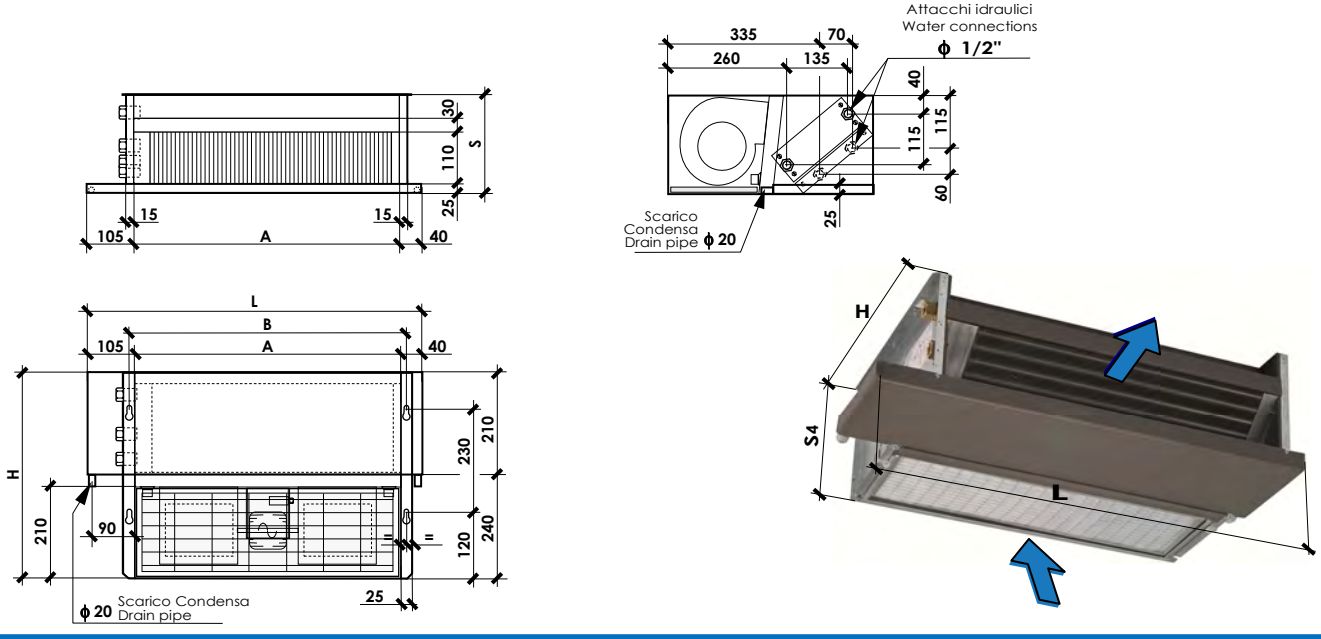

Taglia - Size		DF-X, FXE, ...	100	200	300	400	500	600	700	800	900	1000	1100	1200
Dimensioni principali Main dimensions	L	mm	545	545	745	745	945	945	1145	1145	1345	1345	1545	1545
	H	mm	450	450	450	450	450	450	450	450	450	450	450	450
	S	mm	215	215	215	215	215	215	215	215	215	215	215	215
	A	mm	400	400	600	600	800	800	1.000	1.000	1.200	1.200	1.400	1.400
	B	mm	425	425	625	625	825	825	1.025	1.025	1.225	1.225	1.425	1.425
N° Motori			1	1	1	1	1	1	1	1	1	1	1	1
N° Ventilatori			1	1	1	1	2	2	2	2	2	2	3	3
Batteria caldo/freddo Heating/cooling coil	Contenuto acqua Water volume (l)		0,69	0,70	0,99	1,01	1,30	1,31	1,60	1,62	1,91	1,92	2,21	2,23
	Ranghi - Rows DN(*)		3R 1/2" F	3R 1/2" F	3R 1/2" F	3R 1/2" F	3R 1/2" F	3R 1/2" F	3R 1/2" F	3R 1/2" F	3R 1/2" F	3R 1/2" F	3R 1/2" F	3R 1/2" F
Batteria caldo Heating coil	Contenuto acqua Water volume (l)		0,23	0,23	0,33	0,33	0,43	0,43	0,54	0,54	0,64	0,64	0,74	0,74
	Ranghi - Rows DN(*)		1R 1/2" F	1R 1/2" F	1R 1/2" F	1R 1/2" F	1R 1/2" F	1R 1/2" F	1R 1/2" F	1R 1/2" F	1R 1/2" F	1R 1/2" F	1R 1/2" F	1R 1/2" F
Scarico condensa - Drain pipe		φ(mm)	20	20	20	20	20	20	20	20	20	20	20	20
FX	Ref. FAN-DECK		C2, A40.6V, [P2-3-5],[N1-2-4]		C3.15, A40.6V, [P2-3-5],[N1-2-4]		C3.15, A80.6V, [P2-3-5],[N1-2-4]		C5, A80.6V, [P2-3-5],[N1-2-4]		C3.15, A80.6V, [P2-3-5],[N1-2-4]		C3.15, 5V, [P2-3-4],[ND.1-3-4]	
	Peso netto	2 Tubi/Pipe	Kg	11,0	11,5	13,8	14,6	19,8	20,8	23,1	24,6	27,0	28,5	29,8
	Net weight	4 Tubi/Pipe	Kg	11,9	12,4	14,8	15,6	20,9	21,9	24,3	25,8	28,3	29,8	31,2
FX-P	Ref. FAN-DECK		C3.15, A40.6V, [P2-3-5],[N1-2-4]		C3.15, A80.6V, [P2-3-5],[N1-2-4]		C2, A80.6V, [P2-3-5],[N1-2-4]		C4, A80.6V, [P2-3-5],[N1-2-4]		C4, 6V, [P2-3-4],[N1-3-5]		C4, 5V, [P2-3-4],[N1-3-4]	
	Peso netto	2 Tubi/Pipe	Kg	11,6	12,1	14,6	15,4	20,3	21,3	24,0	25,5	28,1	29,6	30,9
	Net weight	4 Tubi/Pipe	Kg	12,5	13,0	15,6	16,4	21,4	22,4	25,2	26,7	29,4	30,9	32,3
FX-S	Ref. FAN-DECK		C1.5, A40.6V, [P4-5-6],[N4-5-6]		C2.5, A40.6V, [P4-5-6],[N4-5-6]		C2.5, A80.6V, [P4-5-6],[N4-5-6]		C4, A80.6V, [P4-5-6],[N4-5-6]		C2.5, A80.6V, [P4-5-6],[N4-5-6]		C4, V3-A240, [P4-5-6],[N4-5-6]	
	Peso netto	2 Tubi/Pipe	Kg	11,7	12,2	14,5	15,3	20,5	21,5	23,8	25,3	27,7	29,2	30,5
	Net weight	4 Tubi/Pipe	Kg	12,6	13,1	15,5	16,3	21,6	22,6	25,0	26,5	29,0	30,5	31,9
FXE	Ref. FAN-DECK		SWP/STD.1/10, SWN/STD.1/10		SWP/STD.1/10, SWN/STD.1/10		SWP/STD.1/10, SWN/Pot.1/10		SWP/STD.1/10, SWN/Pot.1/10		SWP/STD.1/10, SWN/Pot.1/10		SWP/RFX.1/10, SWD/RXD.1/10	
	Peso netto	2 Tubi/Pipe	Kg	10,6	11,1	13,9	14,7	20,2	21,2	23,0	24,5	26,1	27,6	29,6
	Net weight	4 Tubi/Pipe	Kg	11,5	12,0	14,9	15,7	21,3	22,3	24,2	25,7	27,4	28,9	31,0
FXE-P	Ref. FAN-DECK		SWP/STD.1/10, SWD/STD.1/10		SWP/STD.1/10, SWD/STD.1/10		SWP/Pot.1/10, SWD/Pot.1/10		SWP/Pot.1/10, SWD/Pot.1/10		SWP/RFX.1/10, SWD/RFX.1/10		SWP/RFX.1/10, SWD/RXD.1/10	
	Peso netto	2 Tubi/Pipe	Kg	10,9	11,4	14,2	15,0	20,5	21,5	23,3	24,8	26,4	27,9	29,9
	Net weight	4 Tubi/Pipe	Kg	11,8	12,3	15,2	16,0	21,6	22,6	24,5	26,0	27,7	29,2	31,3
FXE-S	Ref. FAN-DECK		SWP/STD.1/7, SWD/STD.1/7		SWP/STD.1/7, SWD/STD.1/7		SWP/STD.1/7, SWD/STD.1/7		SWP/STD.1/8, SWD/STD.1/8		SWP/STD.1/9, SWD/STD.1/9		SWP/RFX.1/10, SWD/RXD.2/1/10	
	Peso netto	2 Tubi/Pipe	Kg	11,6	12,1	14,9	15,7	21,2	22,2	24,0	25,5	27,1	28,6	30,6
	Net weight	4 Tubi/Pipe	Kg	12,5	13,0	15,9	16,7	22,3	23,3	25,2	26,7	28,4	29,9	32,0
FXE+	Ref. FAN-DECK		SWP/STD.1/10, SWN/STD.1/10		SWP/STD.1/10, SWN/STD.1/10		Non disponibile		Non disponibile		Non disponibile		Non disponibile	
	Peso netto	2 Tubi/Pipe	Kg	11,4	11,9	14,7	15,5	Not available		Not available		Not available		
	Net weight	4 Tubi/Pipe	Kg	12,3	12,8	15,7	16,5	Not available		Not available		Not available		

DN(*) = Diametro nominale, F = Attacchi idraulici batteria Gas femmina

DN(*) = Nominal diameter, F = Female gas water coil connections

• Peso netto= solo unità, escluso imballo

• Net weight= unit only, excluding packaging

Versione incasso orizzontale (base; senza mobile) – Estrazione filtro dal basso Horizontal concealed version (basic; without cabinet) – Downward filter extraction

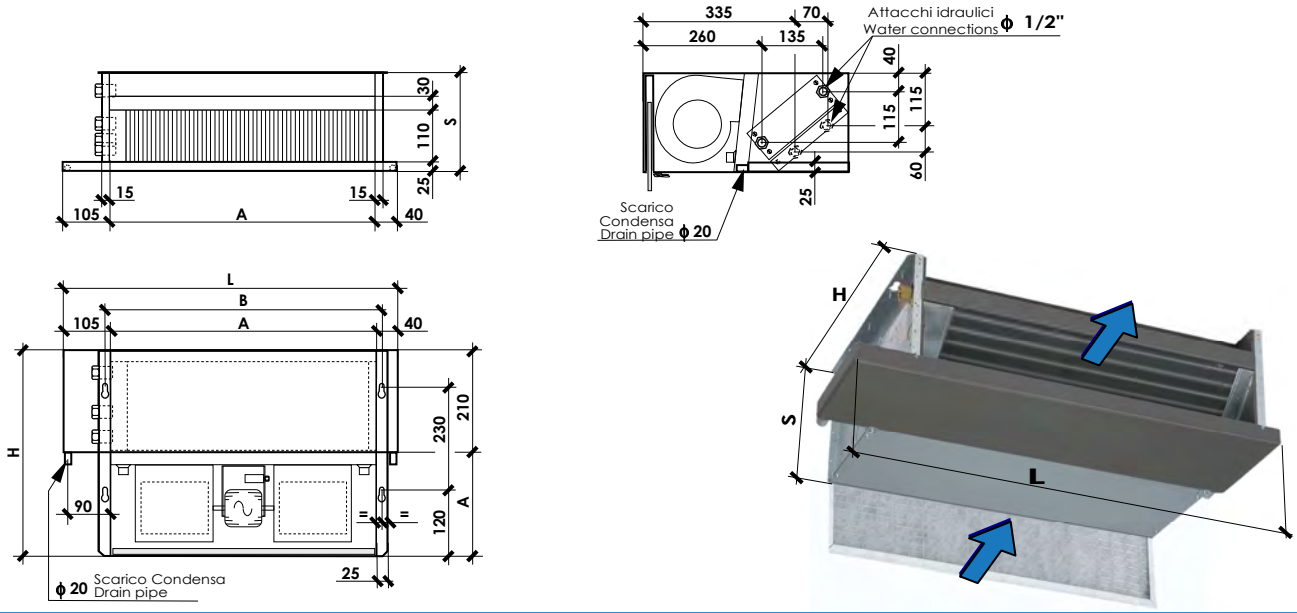

Taglia - Size			DF-X, FXE, ...	100	200	300	400	500	600	700	800	900	1000	1100	1200
Dimensioni principali Main dimensions	L	mm		545	545	745	745	945	945	1145	1145	1345	1345	1545	1545
	H	mm		450	450	450	450	450	450	450	450	450	450	450	450
	S	mm		215	215	215	215	215	215	215	215	215	215	215	215
	A	mm		400	400	600	600	800	800	1.000	1.000	1.200	1.200	1.400	1.400
	B	mm		425	425	625	625	825	825	1.025	1.025	1.225	1.225	1.425	1.425
N° Motori				1	1	1	1	1	1	1	1	1	1	1	1
N° Ventilatori				1	1	1	1	2	2	2	2	2	2	3	3
Batteria caldo/freddo Heating/cooling coil	Contenuto acqua Water volume (l)			0,69	0,70	0,99	1,01	1,30	1,31	1,60	1,62	1,91	1,92	2,21	2,23
	Ranghi - Rows DN(*)			3R 1/2" F	3R 1/2" F	3R 1/2" F	3R 1/2" F	3R 1/2" F	3R 1/2" F	3R 1/2" F	3R 1/2" F	3R 1/2" F	3R 1/2" F	3R 1/2" F	3R 1/2" F
Batteria caldo Heating coil	Contenuto acqua Water volume (l)			0,23	0,23	0,33	0,33	0,43	0,43	0,54	0,54	0,64	0,64	0,74	0,74
	Ranghi - Rows DN(*)			1R 1/2" F	1R 1/2" F	1R 1/2" F	1R 1/2" F	1R 1/2" F	1R 1/2" F	1R 1/2" F	1R 1/2" F	1R 1/2" F	1R 1/2" F	1R 1/2" F	1R 1/2" F
Scarico condensa - Drain pipe			φ(mm)	20	20	20	20	20	20	20	20	20	20	20	20
FX	Ref. FAN-DECK			C2, A40.6V, [P2-3-5],[N1-2-4]	C3.15, A40.6V, [P2-3-5],[N1-2-4]	C3.15, A40.6V, [P2-3-5],[N1-2-4]	C3.15, A40.6V, [P2-3-5],[N1-2-4]	C3.15, A80.6V, [P2-3-5],[N1-2-4]	C3.15, A80.6V, [P2-3-5],[N1-2-4]	C5, A80.6V, [P2-3-5],[N1-2-4]	C5, A80.6V, [P2-3-5],[N1-2-4]	C3.15, A80.6V, [P2-3-5],[N1-2-4]	C3.15, 5V, [P2-3-4],[ND.1-3-4]	C3.15, 5V, [P2-3-4],[ND.1-3-4]	C3.15, 5V, [P2-3-4],[ND.1-3-4]
	Peso netto	2 Tubi/Pipe	Kg	11,2	11,7	14,0	14,8	20,0	21,0	23,4	24,9	27,3	28,8	30,1	33,6
	Net weight	4 Tubi/Pipe	Kg	12,1	12,6	15,0	15,8	21,1	22,1	24,6	26,1	28,6	30,1	31,5	35,0
FX-P	Ref. FAN-DECK			C3.15, A40.6V, [P2-3-5],[N1-2-4]	C3.15, A80.6V, [P2-3-5],[N1-2-4]	C2, A80.6V, [P2-3-5],[N1-2-4]	C2, A80.6V, [P2-3-5],[N1-2-4]	C4, A80.6V, [P2-3-5],[N1-2-4]	C4, A80.6V, [P2-3-5],[N1-2-4]	C4, 6V, [P2-3-4],[N1-3-5]	C4, 6V, [P2-3-4],[N1-3-5]	C4, 5V, [P2-3-4],[N1-3-4]	C4, 5V, [P2-3-4],[N1-3-4]	C4, 5V, [P2-3-4],[N1-3-4]	C4, 5V, [P2-3-4],[N1-3-4]
	Peso netto	2 Tubi/Pipe	Kg	11,8	12,3	14,8	15,6	20,5	21,5	24,3	25,8	28,4	29,9	31,2	34,7
	Net weight	4 Tubi/Pipe	Kg	12,7	13,2	15,8	16,6	21,6	22,6	25,5	27,0	29,7	31,2	32,4	36,1
FX-S	Ref. FAN-DECK			C1.5, A40.6V, [P4-5-6],[N4-5-6]	C2.5, A40.6V, [P4-5-6],[N4-5-6]	C2.5, A40.6V, [P4-5-6],[N4-5-6]	C2.5, A40.6V, [P4-5-6],[N4-5-6]	C2.5, A80.6V, [P4-5-6],[N4-5-6]	C2.5, A80.6V, [P4-5-6],[N4-5-6]	C4, A80.6V, [P4-5-6],[N4-5-6]	C4, A80.6V, [P4-5-6],[N4-5-6]	C2.5, A80.6V, [P4-5-6],[N4-5-6]	C4, V3-A240, [P4-5-6],[N4-5-6]	C4, V3-A240, [P4-5-6],[N4-5-6]	C4, V3-A240, [P4-5-6],[N4-5-6]
	Peso netto	2 Tubi/Pipe	Kg	11,9	12,4	14,7	15,5	20,7	21,7	24,1	25,6	28,0	29,5	30,8	34,3
	Net weight	4 Tubi/Pipe	Kg	12,8	13,3	15,7	16,5	21,8	22,8	25,3	26,8	29,3	30,8	32,2	35,7
FXE	Ref. FAN-DECK			SWP/STD.1/10, SWN/STD.1/10	SWP/STD.1/10, SWN/STD.1/10	SWP/STD.1/10, SWN/STD.1/10	SWP/STD.1/10, SWN/STD.1/10	SWP/STD.1/10, SWN/Pot.1/10	SWP/STD.1/10, SWN/Pot.1/10	SWP/STD.1/10, SWN/Pot.1/10	SWP/STD.1/10, SWN/Pot.1/10	SWP/STD.1/10, SWN/Pot.1/10	SWP/STD.1/10, SWN/Pot.1/10	SWP/STD.1/10, SWN/Pot.1/10	SWP/STD.1/10, SWN/Pot.1/10
	Peso netto	2 Tubi/Pipe	Kg	10,8	11,3	14,1	14,9	20,4	21,4	23,3	24,8	26,4	27,9	29,9	33,4
	Net weight	4 Tubi/Pipe	Kg	11,7	12,2	15,1	15,9	21,5	22,5	24,5	26,0	27,7	29,2	31,3	34,8
FXE-P	Ref. FAN-DECK			SWP/STD.1/10, SWD/STD.1/10	SWP/STD.1/10, SWD/STD.1/10	SWP/STD.1/10, SWD/STD.1/10	SWP/STD.1/10, SWD/STD.1/10	SWP/Pot.1/10, SWD/Pot.1/10	SWP/Pot.1/10, SWD/Pot.1/10	SWP/Pot.1/10, SWD/Pot.1/10	SWP/Pot.1/10, SWD/Pot.1/10	SWP/FIX.1/10, SWD/FIX.1/10	SWP/FIX.1/10, SWD/FIX.1/10	SWP/FIX.1/10, SWD/FIX.1/10	SWP/FIX.1/10, SWD/FIX.1/10
	Peso netto	2 Tubi/Pipe	Kg	11,1	11,6	14,4	15,2	20,7	21,7	23,6	25,1	26,7	28,2	30,2	33,7
	Net weight	4 Tubi/Pipe	Kg	12,0	12,5	15,4	16,2	21,8	22,8	24,8	26,3	28,0	29,5	31,6	35,1
FXE-S	Ref. FAN-DECK			SWP/STD.1/7, SWD/STD.1/7	SWP/STD.1/7, SWD/STD.1/7	SWP/STD.1/7, SWD/STD.1/7	SWP/STD.1/7, SWD/STD.1/7	SWP/STD.1/7, SWD/STD.1/7	SWP/STD.1/7, SWD/STD.1/7	SWP/STD.1/8, SWD/STD.1/8	SWP/STD.1/8, SWD/STD.1/8	SWP/STD.1/9, SWD/STD.1/9	SWP/FIX.1/10, SWD/FIX.1/10	SWP/FIX.1/10, SWD/FIX.1/10	SWP/FIX.1/10, SWD/FIX.1/10
	Peso netto	2 Tubi/Pipe	Kg	11,8	12,3	15,1	15,9	21,4	22,4	24,3	25,8	27,4	28,9	30,9	34,4
	Net weight	4 Tubi/Pipe	Kg	12,7	13,2	16,1	16,9	22,5	23,5	25,5	27,0	28,7	30,2	32,3	35,8
FXE+	Ref. FAN-DECK			SWP/STD.1/10, SWN/STD.1/10	SWP/STD.1/10, SWN/STD.1/10	SWP/STD.1/10, SWN/STD.1/10	SWP/STD.1/10, SWN/STD.1/10	Non disponibile	Non disponibile	Non disponibile	Non disponibile	Non disponibile	Non disponibile	Non disponibile	Non disponibile
	Peso netto	2 Tubi/Pipe	Kg	11,6	12,1	14,9	15,7	Non disponibile	Non disponibile	Non disponibile	Non disponibile	Non disponibile	Non disponibile	Non disponibile	Non disponibile
	Net weight	4 Tubi/Pipe	Kg	12,5	13,0	15,9	16,7	Non disponibile	Non disponibile	Non disponibile	Non disponibile	Non disponibile	Non disponibile	Non disponibile	Non disponibile

DN(*) = Diametro nominale, F = Attacchi idraulici batteria Gas femmina

DN(*) = Nominal diameter, F = Female gas water coil connections

• Peso netto= solo unità, escluso imballo

• Net weight= unit only, excluding packaging

Versione incasso orizzontale (base; senza mobile) – Estrazione filtro dall'alto Horizontal concealed version (basic; without cabinet) – Upward filter extraction

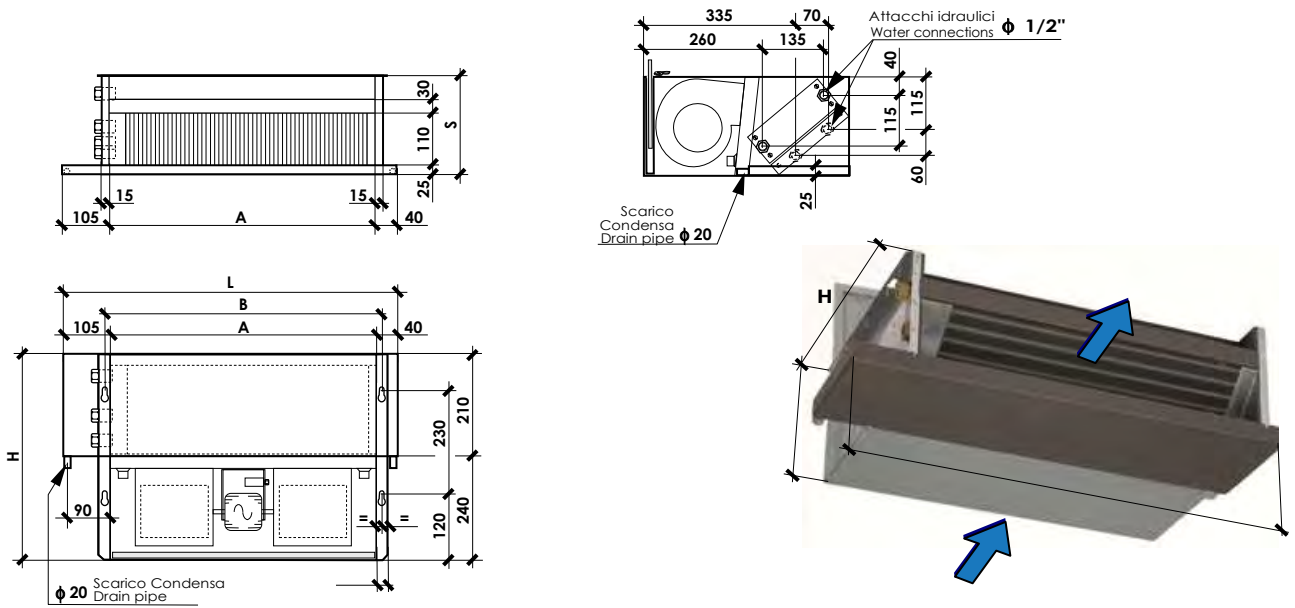

Taglia - Size		DF-X, FXE, ...	100	200	300	400	500	600	700	800	900	1000	1100	1200	
Dimensioni principali Main dimensions	L	mm	545	545	745	745	945	945	1145	1145	1345	1345	1545	1545	
	H	mm	450	450	450	450	450	450	450	450	450	450	450	450	
	S	mm	215	215	215	215	215	215	215	215	215	215	215	215	
	A	mm	400	400	600	600	800	800	1.000	1.000	1.200	1.200	1.400	1.400	
	B	mm	425	425	625	625	825	825	1.025	1.025	1.225	1.225	1.425	1.425	
N° Motori			1	1	1	1	1	1	1	1	1	1	1	1	
N° Ventilatori			1	1	1	1	2	2	2	2	2	2	3	3	
Batteria caldo/freddo Heating/cooling coil	Contenuto acqua Water volume (l)		0,69	0,70	0,99	1,01	1,30	1,31	1,60	1,62	1,91	1,92	2,21	2,23	
	Ranghi - Rows DN(*)		3R 1/2" F	3R 1/2" F	3R 1/2" F	3R 1/2" F	3R 1/2" F	3R 1/2" F	3R 1/2" F	3R 1/2" F	3R 1/2" F	3R 1/2" F	3R 1/2" F	3R 1/2" F	
Batteria caldo Heating coil	Contenuto acqua Water volume (l)		0,23	0,23	0,33	0,33	0,43	0,43	0,54	0,54	0,64	0,64	0,74	0,74	
	Ranghi - Rows DN(*)		1R 1/2" F	1R 1/2" F	1R 1/2" F	1R 1/2" F	1R 1/2" F	1R 1/2" F	1R 1/2" F	1R 1/2" F	1R 1/2" F	1R 1/2" F	1R 1/2" F	1R 1/2" F	
Scarico condensa - Drain pipe		φ(mm)	20	20	20	20	20	20	20	20	20	20	20	20	
FX	Ref. FAN-DECK		C2, A40.6V, [P2-3-5],[N1-2-4]		C3.15, A40.6V, [P2-3-5],[N1-2-4]		C3.15, A80.6V, [P2-3-5],[N1-2-4]		C5, A80.6V, [P2-3-5],[N1-2-4]		C3.15, A80.6V, [P2-3-5],[N1-2-4]		C3.15, 5V, [P2-3-4],[ND.1-3-4]		
	Peso netto	2 Tubi/Pipe	Kg	11,2	11,7	14,0	14,8	20,0	21,0	23,4	24,9	27,3	28,8	30,1	33,6
	Net weight	4 Tubi/Pipe	Kg	12,1	12,6	15,0	15,8	21,1	22,1	24,6	26,1	28,6	30,1	31,5	35,0
FX-P	Ref. FAN-DECK		C3.15, A40.6V, [P2-3-5],[N1-2-4]		C3.15, A80.6V, [P2-3-5],[N1-2-4]		C2, A80.6V, [P2-3-5],[N1-2-4]		C4, A80.6V, [P2-3-5],[N1-2-4]		C4, 6V, [P2-3-4],[N1-3-5]		C4, 5V, [P2-3-4],[N1-3-4]		
	Peso netto	2 Tubi/Pipe	Kg	11,8	12,3	14,8	15,6	20,5	21,5	24,3	25,8	28,4	29,9	31,2	34,7
	Net weight	4 Tubi/Pipe	Kg	12,7	13,2	15,8	16,6	21,6	22,6	25,5	27,0	29,7	31,2	32,4	36,1
FX-S	Ref. FAN-DECK		C1.5, A40.6V, [P4-5-6],[N4-5-6]		C2.5, A40.6V, [P4-5-6],[N4-5-6]		C2.5, A80.6V, [P4-5-6],[N4-5-6]		C4, A80.6V, [P4-5-6],[N4-5-6]		C2.5, A80.6V, [P4-5-6],[N4-5-6]		C4, V3-A240, [P4-5-6],[N4-5-6]		
	Peso netto	2 Tubi/Pipe	Kg	11,9	12,4	14,7	15,5	20,7	21,7	24,1	25,6	28,0	29,5	30,8	34,3
	Net weight	4 Tubi/Pipe	Kg	12,8	13,3	15,7	16,5	21,8	22,8	25,3	26,8	29,3	30,8	32,2	35,7
FXE	Ref. FAN-DECK		SWP/STD.1/10, SWN/STD.1/10		SWP/STD.1/10, SWN/STD.1/10		SWP/STD.1/10, SWN/Pot1.D.1/10		SWP/STD.1/10, SWN/Pot1.D.1/10		SWP/STD.1/10, SWN/Pot1.1/10		SWP/STD.1/10, SWD/RXD.1/10		
	Peso netto	2 Tubi/Pipe	Kg	10,8	11,3	14,1	14,9	20,4	21,4	23,3	24,8	26,4	27,9	29,9	33,4
	Net weight	4 Tubi/Pipe	Kg	11,7	12,2	15,1	15,9	21,5	22,5	24,5	26,0	27,7	29,2	31,3	34,8
FXE-P	Ref. FAN-DECK		SWP/STD.1/10, SWD/STD.1/10		SWP/STD.1/10, SWD/STD.1/10		SWP/Pot1.1/10, SWD/Pot1.1/10		SWP/Pot1.1/10, SWD/Pot1.1/10		SWP/STD.1/10, SWD/STD.1/10		SWP/STD.1/10, SWD/STD.1/10		
	Peso netto	2 Tubi/Pipe	Kg	11,1	11,6	14,4	15,2	20,7	21,7	23,6	25,1	26,7	28,2	30,2	33,7
	Net weight	4 Tubi/Pipe	Kg	12,0	12,5	15,4	16,2	21,8	22,8	24,8	26,3	28,0	29,5	31,6	35,1
FXE-S	Ref. FAN-DECK		SWP/STD.1/7, SWD/STD.1/7		SWP/STD.1/7, SWD/STD.1/7		SWP/STD.1/7, SWD/STD.1/7		SWP/STD.1/8, SWD/STD.1/8		SWP/STD.1/9, SWD/STD.1/9		SWP/STD.1/10, SWD/RXD.1/10		
	Peso netto	2 Tubi/Pipe	Kg	11,8	12,3	15,1	15,9	21,4	22,4	24,3	25,8	27,4	28,9	30,9	34,4
	Net weight	4 Tubi/Pipe	Kg	12,7	13,2	16,1	16,9	22,5	23,5	25,5	27,0	28,7	30,2	32,3	35,8
FXE+	Ref. FAN-DECK		SWP/STD.1/10, SWN/STD.1/10		SWP/STD.1/10, SWN/STD.1/10		Non disponibile		Non disponibile		Non disponibile		Non disponibile		
	Peso netto	2 Tubi/Pipe	Kg	11,6	12,1	14,9	15,7	Not available		Not available		Not available			
	Net weight	4 Tubi/Pipe	Kg	12,5	13,0	15,9	16,7	Not available		Not available		Not available			

DN(*) = Diametro nominale, F = Attacchi idraulici batteria Gas femmina

DN(*) = Nominal diameter, F = Female gas water coil connections

• Peso netto= solo unità, escluso imballo

• Net weight= unit only, excluding packaging

Dimatek®

DIMATEK COMFORT SOLUTIONS, S.L.



- EN** WE RESERVE THE RIGHT TO CHANGE ALL OR PART OF THE FEATURES OF THE ARTICLES OR CONTENTS OF THIS DOCUMENT, WITHOUT PRIOR NOTICE
- ES** NOS RESERVAMOS EL DERECHO DE CAMBIAR TOTAL O PARCIALMENTE LAS CARACTERÍSTICAS DE NUESTROS ARTÍCULOS O CONTENIDO DE ESTE DOCUMENTO SIN PREVIO AVISO.
- FR** NOUS NOUS RÉSERVONS LE DROIT DE MODIFIER EN TOUT OU EN PARTIE LES CARACTÉRISTIQUES DE NOS ARTICLES OU LE CONTENU DE CE DOCUMENT SANS AVIS
- DE** DE WIR BEHALTEN UNS DAS RECHT VOR, DIE CHARAKTERISTIKA UNSERER PRODUKTE ODER DEN INHALT DIESES DOKUMENTS OHNE VORHERIGE ANKÜNDIGUNG VOLLSTÄNDIG ODER TEILWEISE ZU ÄNDERN.
- IT** CI RISERVIAMO IL DIRITTO DI MODIFICARE IN TUTTO O IN PARTE LE CARATTERISTICHE DEI NOSTRI ARTICOLI O CONTENUTO DI QUESTO DOCUMENTO SENZA PREAVVISO.
- NE** WIJ BEHOUDEN ONS HET RECHT VOOR OM DE KENMERKEN VAN DE ARTIKELS OF DE INHOUD VAN DIT DOCUMENT ZONDER VOORAF GAANDE KENNISGEVING GEHEEL OF GEDEELTELIJK TE WIJZIGEN.
- PO** RESERVAMO-NOS O DIREITO DE ALTERAR TOTAL OU PARCIALMENTE AS CARACTERÍSTICAS DOS NOSSOS ARTIGOS OU O CONTEÚDO DESTE DOCUMENTO SEM AVISO PRÉVIO.