



The ECI Motor – dynamics, performance and high flexibility



Technical Information

You are looking for high dynamic properties, high torque and full power on demand? The electronically commutated inner rotor motors of the ECI series are the professional drive solution when short cycle times fast motion-sequences and long lifetime are required.

With the electronic commutation of the ECI motors the maximum values for life expectancy are made possible. Based on this the ECI motors can be used in many various applications as maintenance-free drive components throughout the entire life span of the device or machine. Depending on the motor type and size the commutation electronics to operate these motors is available either as integrated or external version.

High power density has been achieved by using highly efficient neodymium magnetic materials. This enables the ECI motors to deliver a high output power out of a comparably small motor volume for a vast variety of applications and assembly situations. For most of the motors in this series the magnets are designed as bar magnets that are embedded into the slots of a stacked rotor lamination core. Being permanently embedded, these magnets are not only efficient to manufacture in automated production, but they can also be used up to high motor speeds without the need for any additional safety measures.

The mechanically closed design of these inner rotor motors enables the motors to reach a protection class of IP 40 already in the standard motor version. Higher protection classes are available on request depending on the exact motor type. In addition the design of the motor flanges with various diameters of bore holes on different reference circle diameters offers extremely flexible mounting possibilities for the integration of the motors into many various applications. Furthermore several types of the ECI motors can be equipped with low-noise planetary gears in various ratios in order to adapt speed and torque in a best possible way to the individual requirements of your application.

In brief and straight to the point

- 3-phase, electronically commutated internal rotor with neodymium magnet
- Power range from 30 to 270 high power density and wide overload margin
- Long service life and silent running
- Determination of rotor position via 3 Hall-sensors
- Several motor types also available with planetary gears
- Optoelectronic encoder for some motor types available on request
- Spring applied brake for some motor types available on request
- Customer-specific winding layouts
- Winding insulation as per Insulation Class E
- Protection class as per EN 60 034-5: IP 40, higher if required

Contents

The series of ECI motors consists of altogether 4 motor sizes that are partially available in different motor lengths. Besides the operating electronics of the series DRIVECONTROL different gearbox versions are available. Further accessory components such as spring applied brakes and encoders that are available on request complete the programme of the ECI motors to make it suitable for the use in a wide range of different applications.



■ ECI-Motor	
■ – Commutation sequence	4
<hr/>	
■ Motor ECI 30	
■ – ECI 30.20	5
<hr/>	
■ Motor ECI 42	
■ – ECI 42.40-C	6
■ – ECI 42.40-C Gear Motor	7
<hr/>	
■ Motor ECI 24	
■ – ECI 24.42	9
■ – ECI 24.80	10
■ – ECI 24.42-CD	11
<hr/>	
■ Motor ECI 63	
■ – ECI 63.25	13
■ – ECI 63.40	14
■ – ECI 63.75	15
■ – ECI 63 Gear Motor	16
<hr/>	
■ ECI-DRIVECONTROL	
■ – ECI VT-D	17
<hr/>	
■ ECI-Brake	
■ – ECI-Spring applied brake	18
<hr/>	
■ ECI-Sensor	
■ – ECI-Encoder HEDS	19
<hr/>	
■ Adresses	20
<hr/>	

ECl motors

The following diagram illustrates the sequence of the Hall signals and the corresponding drive sequence with relevant colour and pin assignments that apply to self-developed products and to purchased electronics. It also illustrates the phase position of these signals to the induced motor voltage.

Commutation sequences

Commutation sequence

Chronological signal sequence of integrated Hall sensors (= RLG) at the corresponding connections.

Switching sequences of the power output stage

Required relationship between the signal change from RLG and the relevant change for the switching status of the power transistors in relation to the phase lead to the motor.

Induced voltages

Idealized illustration of the sequence of the induced voltages between the relevant connections.

Total of induced voltages

Supply voltage for

Hall-IC A 3187 LUA

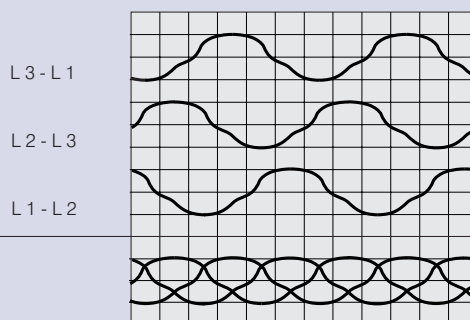
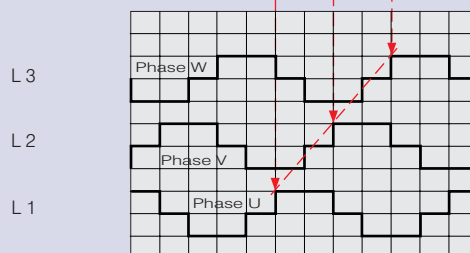
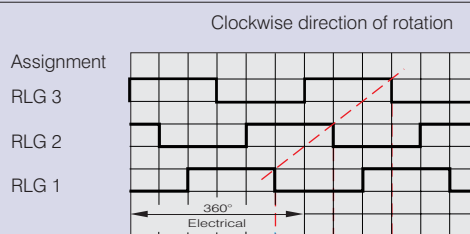

ECl
Position
grey
white
green
yellow
violet
brown
yellow-brown
violet-yellow
brown-violet
red
black

Sensor-Plug ECl 24.XX / 63.XX

Type: Molex
No. 39-01-2085

1: —	2: red	3: white
4: green	5: —	6: —
7: black	8: grey	

Power-Plug ECl 24.XX / 63.XX

Type: Molex
No. 19-09-1036

1: yellow	2: violet	3: brown
-----------	-----------	----------

Hall-IC

Supply voltage range:
 $V_{CC} = 4.5 \dots 24 \text{ V}$
 Signal output: open collector
 Max. output voltage: $V_o = 26 \text{ V}$
 Max. output current: $I_o = 20 \text{ mA}$

ECl-Motor

ECl 30.20



- High dynamic 3-phase, 6-pulse internal rotor motor.
- EC technology with slotless stator design.
- Extremely silent running, no cogging torque.
- Very suitable for high speed applications due to minimized iron losses.
- Dynamically balanced rotor with 4-pole neodymium magnet.
- Detection of rotor position via 3 Hall sensors.
Option: motor without sensors for sensorless operation.
- Precision ball bearings for long service life and silent running.
- Motor supply and control via external operating electronics.

Nominal Data

Type	ECl 30.20	
Nominal voltage (U_{BN})	V DC	24
Nominal speed (n_N)	min ⁻¹	30 000
Nominal torque (M_N)	mNm	10
Nominal current (I_{BN})	A	1.9
Nominal output power (P_N)	W	32
Free-running speed (n_I)	min ⁻¹	43 000
Free-running current (I_{BL})	A	0.20
Permanent stall torque (M_{BNO})	mNm	---
Permissible eff. stall current, motor lead (I_{n0eff})	A	---
Permissible permanent input power at stall (P_{BNO})	W	---
Short-term permiss. peak torque (M_{max})	mNm	45
Permiss. peak current, motor lead (I_{max})	A	8
Induced voltage (U_{imax})	V/1000min ⁻¹	0.62
Terminal resistance (R_V)	Ω	1.9
Terminal inductance (L_V)	mH	0.26
Rotor moment of inertia (J_R)	kgm ² x10 ⁻⁶	1.5
Thermal resistance (R_{th})	K/W	---
Protection class		IP 20
Ambient temperature range (T_U)	°C	0...+40
Motor mass (m)	kg	0.21
Order No.		932 3020 001

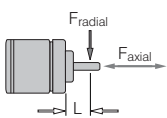

F_{axial} 6 N
 F_{radial} 1 N L_1 10 mm

Permissible shaft load at nominal speed and life expectancy L_{10} at 20 000 h.

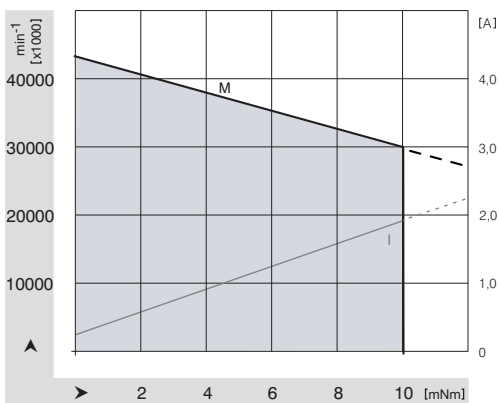

Operating electronics:
DRIVECONTROL VT-A in a version without speed control can be used for tests (adapter cable necessary).

Blind holes for self threading screws according to DIN 7500. Screw in depth 5,3 mm max.

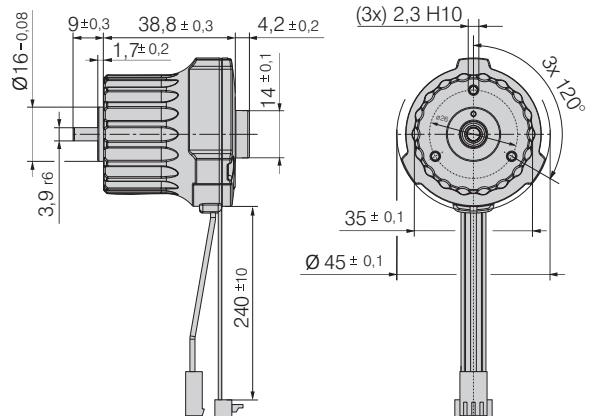

ECl-Motor

ECl 42.40-C



- Dynamic 3-phase internal rotor motor in EC technology with increased starting torque.
- Integrated operating electronics with powerful microcontroller.
- Excellent controllability due to digital 4-Q PI controller.
- High efficiency due to FET power stage.
- Analog set value.
- Protection against overload due to integrated, speed-dependent current limiting.
- Customized versions possible by software and hardware adaption (e.g. fixed speed, direction of rotation).

Nominal Data

Type		ECl 42.40-C	... 610
Nominal voltage (U_{BN})	V DC	24 (18...28)	24 (18...28)
Nominal speed (n_N)	min ⁻¹	6 000	5 000
Nominal torque (M_N)	mNm	80	100
Nominal current (I_{BN})	A	3.0	3.0
Nominal output power (P_N)	W	50	52
Free-running speed (n_I)	min ⁻¹	9 300	6 300
Free-running current (I_{BL})	A	0.30	0.25
Max. reverse voltage	V DC	30	30
Set value input	V	0...10	0...10
Desired speed	min ⁻¹	0...10 000	0...10 000
Recommended speed control range	min ⁻¹	300 ... n_{max}	300 ... n_{max}
Temperature monitoring		yes	yes
Overload protection		yes	yes
Average starting torque	mNm	140	140
Rotor moment of inertia (J_R)	kgm ² x10 ⁻⁶	3.2	3.2
Thermal resistance (R_{th})	K/W	3.3	3.3
Protection class		IP 40	IP 40
Ambient temperature range (T_U)	°C	0...+40	0...+40
Motor mass (m)	kg	0.7	0.7
Order No.		932 4240 600	932 4240 610

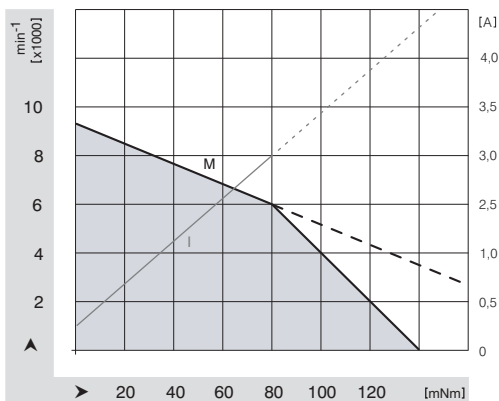
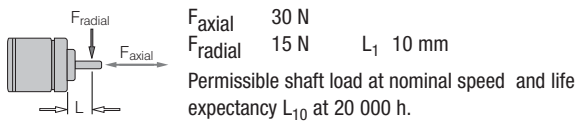

Shaft dimensions
Motor 932 4240 610

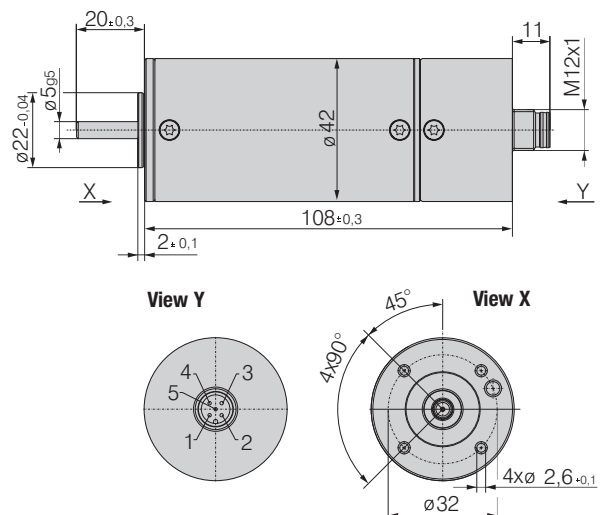
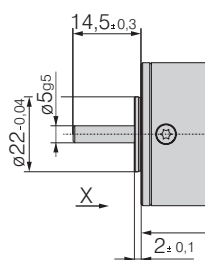

ECI-Gear motor

ECI 42.40-C-PX



- Dynamic 3-phase internal rotor motor in EC technology with increased starting torque.
- Integrated operating electronics with powerful microcontroller.
- Excellent controllability due to digital 4-Q PI controller.
- High efficiency due to FET power stage.
- Analog set value.
- Protection against overload due to integrated, speed-dependent current limiting.
- Customized versions possible by software and hardware adaption (e.g. fixed speed, direction of rotation).

Nominal Data	Gear ratio	Stage gearbox	Nominal torque	Speed range	Length L1	Length L2	Mass	Order No. 942 4240 ...
Type	I		Nm	min ⁻¹	mm	mm	kg	
ECI-42.40-C-PX 42-3	3.18:1	1	0.3	100...1 572	143.3	35.3	0.9	...603
ECI-42.40-C-PX 42-5	5:1	1	0.5	60...1 000	143.3	35.3	0.9	...600
ECI-42.40-C-PX 42-21	21.25:1	2	1.7	14...235	158.8	50.8	1.0	...601
ECI-42.40-C-PX 42-30	30:1	2	2.4	10...167	158.8	50.8	1.0	...602
ECI-42.40-C-PX 42-150	150:1	3	10.3*	2...33	174.3	66.3	1.1	...604

* Limiting of max. output torque to 10.3 Nm required.

Gear Motor PX

One stage and multi-stage planetary gearbox with zinc die-cast housing.

Grease lubrication for maintenance free operation.

Output shaft with combined sleeve- / ball bearings.

Optimized helical gearing for long service life and quiet running in the first stage.

Gear-Output shaft load

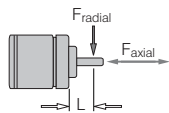

F_{axial} 150 N
 F_{radial} 250 N L_1 12,5 mm

Permissible shaft load at nominal speed and life expectancy L_{10} at 5 000 h.

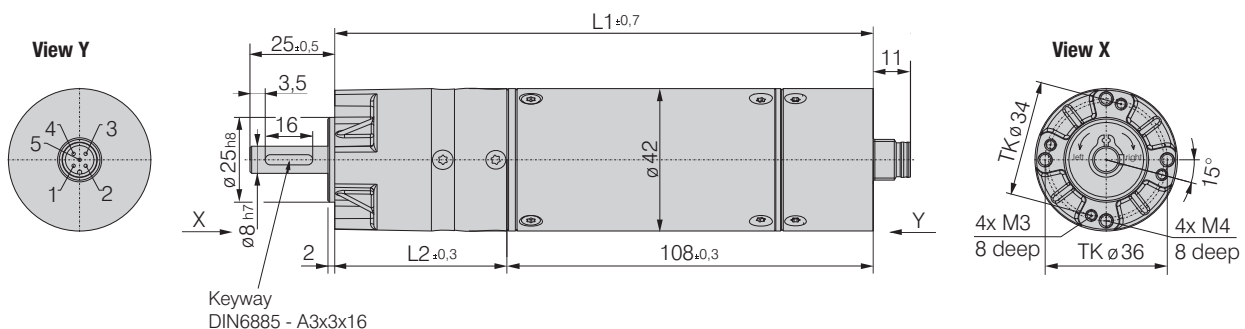

Pin configuration for ECI 42.40-C

Pin connection

Pin 1	U_B
Pin 2	Direction of rotation
Pin 3	GND
Pin 4	ACTUAL speed value
Pin 5	Set value

Pin configuration

Plug Type: Company Lumberg:

Lumberg Type RKT 5-228/...m (direct coupling)

RKT 5-228/2m

ebm-papst Order No. 992 0160 001

Type RKWT 5-228/...m (angle coupling)

Type FST 5-FKT 5-293/...m (Fixcon plug / coupling)

1. Control input rotation (Pin 2)

Pin 2

1 Counterclockwise rotation

0 Clockwise rotation

low (0) 0 ... 0.8 V

high (1) 2.4 ... 28 V

Direction of rotation viewed on shaft

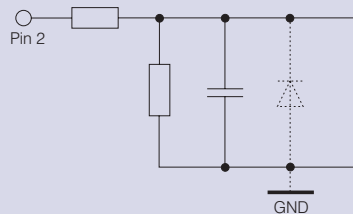

2. Actual speed value output (Pin 4)

Version:

Open Collector

$U_{ext. max} = 30 V$

$U_{CESAT} = 0.5 V$

$I_{C MAX} = 5 mA$

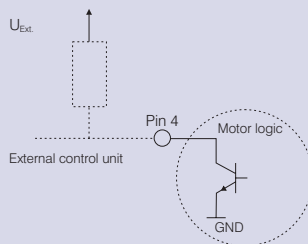

Output signal

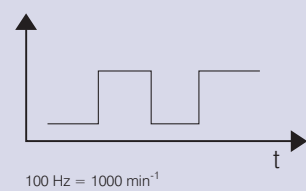

3. Set value input (Pin 5)

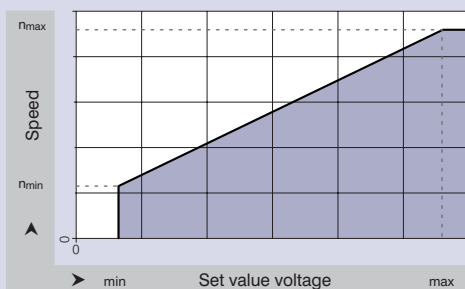

Speed setting for speed control via set value voltage interface 0 ... 10 V DC.
(1 V = 1 000 U/min)

By set value voltage $< 0.2 V$ the brake function will be activated.

The braking function serves to slow down the motor only. It has no holding brake function for static duty.

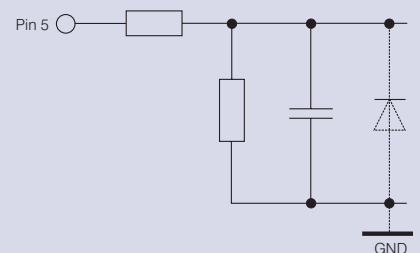

For detailed information, please refer to the corresponding specification data sheets.
The instructions and safety notes in the operating manual must be kept at all times.

ECI-Motor

ECI 24.42



- High dynamic 3-phase, 6-pulse internal rotor motor.
- EC technology.
- Dynamically balanced rotor with 4-pole neodymium magnet.
- Detection of rotor position via 3 Hall sensors.
- Precision ball bearings for long service life and silent running.
- Aluminium housing.
- Motor supply and control via external operating electronics.

Nominal Data

Type	ECI 24.42	
Nominal voltage (U_{BN})	V DC	24
Nominal speed (n_N)	min ⁻¹	3 000
Nominal torque (M_N)	mNm	290
Nominal current (I_{BN})	A	5.7
Nominal output power (P_N)	W	90
Free-running speed (n_I)	min ⁻¹	4 000
Free-running current (I_{BL})	A	0.28
Permanent stall torque (M_{BNO})	mNm	280
Permissible eff. stall current, motor lead (I_{n0eff})	A	5.8
Permissible permanent input power at stall (P_{BNO})	W	31.0
Short-term permiss. peak torque (M_{max})	mNm	800
Permiss. peak current, motor lead (I_{max})	A	16
Induced voltage (U_{imax})	V/1000min ⁻¹	6.0
Terminal resistance (R_v)	Ω	0.67
Terminal inductance (L_v)	mH	1.15
Rotor moment of inertia (J_R)	kgm ² x10 ⁻⁶	9.8
Thermal resistance (R_{th})	K/W	1.96
Protection class		IP 40
Ambient temperature range (T_U)	°C	0...+40
Motor mass (m)	kg	0.85
Order No.		932 2442 001

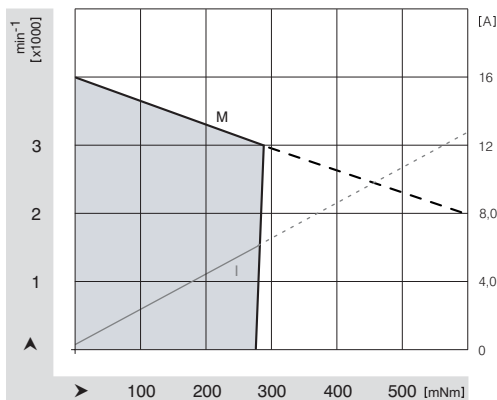
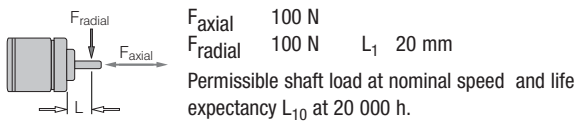

Operating electronics: DRIVECONTROL with analog interface.
Adapted operating electronics DRIVECONTROL VT-D 937 6207 002.

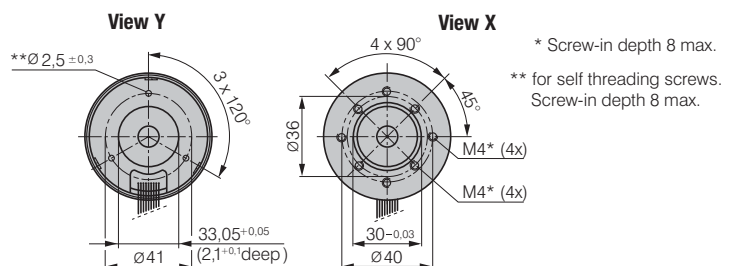
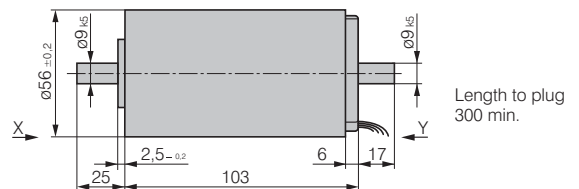

ECl-Motor

ECl 24.80



- High dynamic 3-phase, 6-pulse internal rotor motor.
- EC technology.
- Dynamically balanced rotor with 4-pole neodymium magnet.
- Detection of rotor position via 3 Hall sensors.
- Precision ball bearings for long service life and silent running.
- Aluminium housing.
- Motor supply and control via external operating electronics.

Nominal Data

Type	ECl 24.80	
Nominal voltage (U_{BN})	V DC	24
Nominal speed (n_N)	min ⁻¹	3 000
Nominal torque (M_N)	mNm	590
Nominal current (I_{BN})	A	11
Nominal output power (P_N)	W	185
Free-running speed (n_L)	min ⁻¹	4 000
Free-running current (I_{BL})	A	0.44
Permanent stall torque (M_{BNO})	mNm	520
Permissible eff. stall current, motor lead (I_{n0eff})	A	9.5
Permissible permanent input power at stall (P_{BNO})	W	32.0
Short-term permiss. peak torque (M_{max})	mNm	1 300
Permiss. peak current, motor lead (I_{max})	A	25
Induced voltage (U_{imax})	V/1000min ⁻¹	6.15
Terminal resistance (R_v)	Ω	0.26
Terminal inductance (L_v)	mH	0.57
Rotor moment of inertia (J_R)	kgm ² x10 ⁻⁶	19.2
Thermal resistance (R_{th})	K/W	1.22
Protection class		IP 40
Ambient temperature range (T_U)	°C	0...+40
Motor mass (m)	kg	1.37
Order No.		932 2480 001

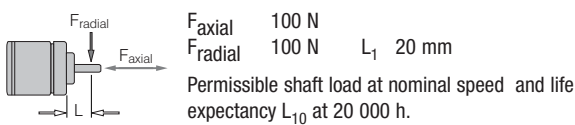

Operating electronics: DRIVECONTROL with analog Interface.
 Adapted operating electronics DRIVECONTROL VT-D 937 6213 003.

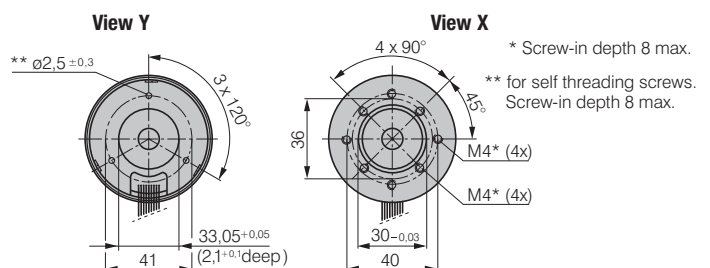
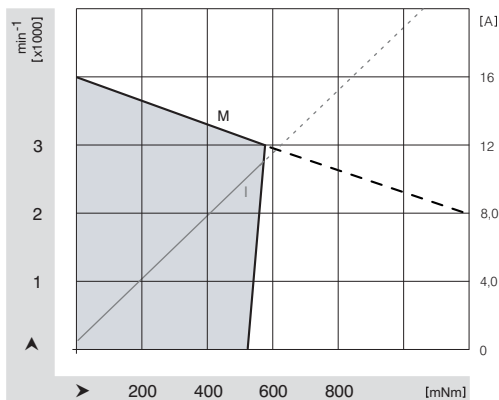
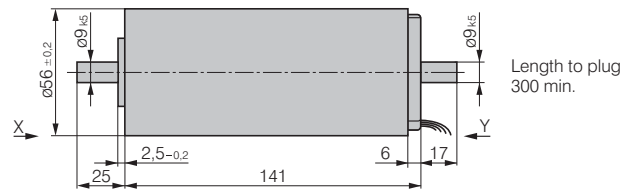

ECI-Compact

ECI 24.42-CD



- High dynamic 3-phase, 6-pulse internal rotor motor.
- EC technology.
- Dynamically balanced rotor with 4-pole neodymium magnet.
- Detection of rotor position via 3 Hall sensors.
- Extremely compact drive system with fully integrated operating electronics for accurate speed control.
- Powerful FET power stage.
- Analog set value with differential input.
- Galvanic isolation of the control signals.

Nominal Data

Type	ECI 24.42-CD	
Nominal voltage (U_{BN})	V DC	24 (18...28)
Nominal speed (n_N)	min ⁻¹	3 000
Nominal torque (M_N)	mNm	290
Nominal current (I_{BN})	A	5.3
Nominal output power (P_N)	W	90
Free-running speed (n_I)	min ⁻¹	4 000
Free-running current (I_{BL})	A	0.4
Max. reverse voltage	V DC	40
Set value input	V	0...10
Desired speed	min ⁻¹	0...4 000
Recommended speed control range	min ⁻¹	300 ... n_{max}
Function for motor protection at stall by stall protection pulsing		---
Overload protection		---
Average starting torque	mNm	290
Rotor moment of inertia (J_R)	kgm ² x10 ⁻⁶	9.8
Thermal resistance (R_{th})	K/W	---
Protection class		IP 40 (IP 54)*
Ambient temperature range (T_U)	°C	0...+40
Motor mass (m)	kg	1.0
Order No.		932 2442 800

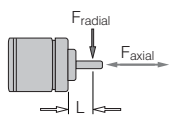

F_{axial} 0 N
 F_{radial} 135 N L_1 10 mm

Permissible shaft load at nominal speed and life expectancy L_{10} at 20 000 h.

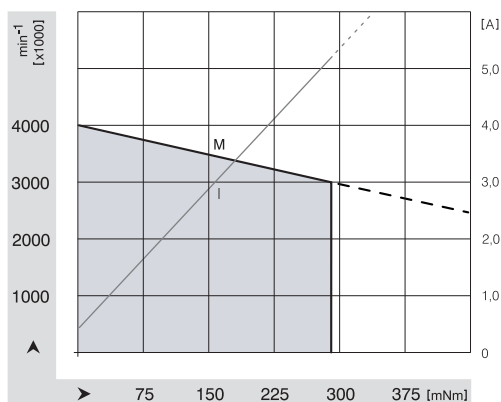

* IP 54 when using a shaft sealing ring and when covering the threaded holes for mounting.

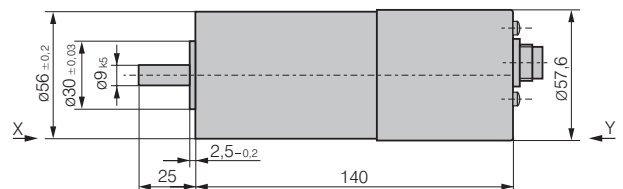

View Y

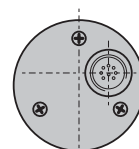

Circular plug-in connector 8-pole. Series 423 Fa. Binder

View X

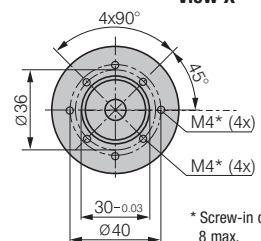

* Screw-in depth 8 max.

Pin configuration for ECI 24.42-CD

Pin connection (Motor plug)

Pin 1	+Ub	Supply voltage
Pin 2	GND	Ground
Pin 5	A	Operating mode
Pin 4	B	Operating mode

Pin 3	S+	Set value input
Pin 6	S-	Ground set value input
Pin 7	ACTUAL	ACTUAL Speed value
Pin 8	GND_IN	Ground I/O

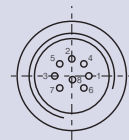

Corresponding mating connector:
(Binder Series 423)
Straight plug ebm-papst
Order No. 992 0370 004

1. Control inputs (galvanically isolated)

A	B	
0	0	Power output stage disabled
0	1	Counterclockwise rotation
1	0	Clockwise rotation
1	1	Brake function*

low (0) 0 ... 5 V
high (1) 15 ... 30 V

*Brake function:
The braking function serves to slow down the motor only. It has no holding brake function for static duty.

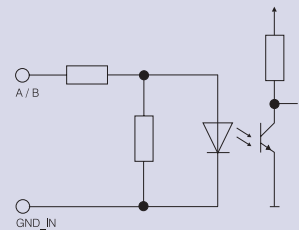

2. ACTUAL speed value output (galvanically isolated)

Version:

Open Collector
 $U_{ext. max} = 30 V$
 $U_{CESAT} = 0.5 V$
 $I_{CMAX} = 5mA$

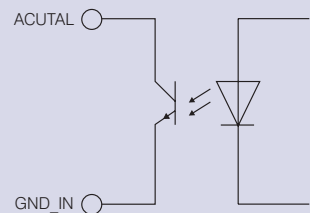
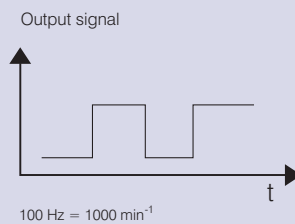

3. Set value input

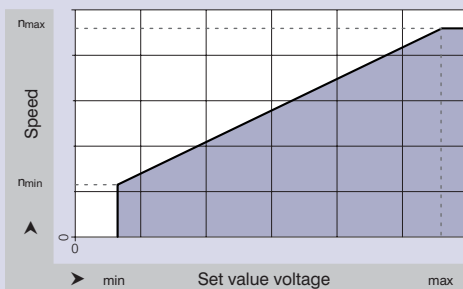

Speed setting for speed control via set value voltage (interface 0 ... 10 V DC).
Differential Input.

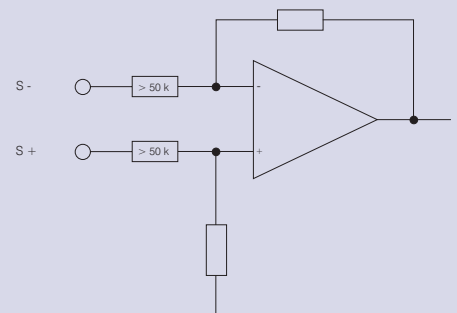

For detailed information, please refer to the corresponding specification data sheets.
The instructions and safety notes in the operating manual must be kept at all times.

ECI-Motor

ECI 63.25



- High dynamic 3-phase, 6-pulse internal rotor motor.
- EC technology.
- 4-pole rotor with inserted neodymium magnets.
- Determination of rotor position via 3 Hall sensors.
- Precision ball bearings for long service life and silent running.
- Steel housing.
- Prepared for mounting of an encoder (HEDS 5500) or a brake.
- Motor supply and control via external operating electronics.
- A-side with fixed bearing seat.

Nominal Data

Type	ECI 63.25	
Nominal voltage (U_{BN})	V DC	24
Nominal speed (n_N)	min ⁻¹	4 000
Nominal torque (M_N)	mNm	200
Nominal current (I_{BN})	A	4.8
Nominal output power (P_N)	W	83
Free-running speed (n_I)	min ⁻¹	5 250
Free-running current (I_{BL})	A	0.26
Permanent stall torque (M_{BN0})	mNm	230
Permissible eff. stall current, motor lead (I_{n0eff})	A	6.1
Permissible permanent input power at stall (P_{BN0})	W	20.0
Short-term permiss. peak torque (M_{max})	mNm	875
Permiss. peak current, motor lead (I_{max})	A	23
Induced voltage (U_{imax})	V/1000min ⁻¹	4.7
Terminal resistance (R_v)	Ω	0.38
Terminal inductance (L_v)	mH	1.6
Rotor moment of inertia (J_R)	kgm ² x10 ⁻⁶	12.6
Thermal resistance (R_{th})	K/W	3.9
Protection class		IP 40
Ambient temperature range (T_U)	°C	0...+40
Motor mass (m)	kg	1.0
Order No.		932 6325 001

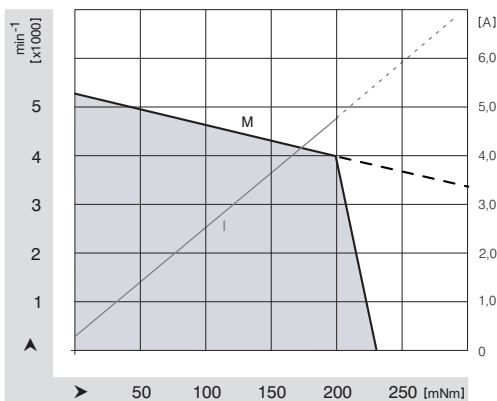
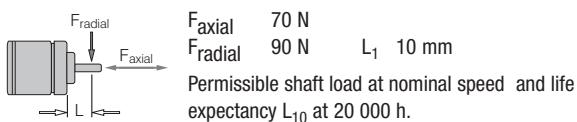

Operating electronics: DRIVECONTROL with analog interface.
Adapted operating electronics DRIVECONTROL VT-D: 937 6207 002

Blind holes for self threading screws according to DIN 7500.

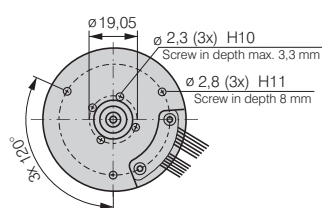
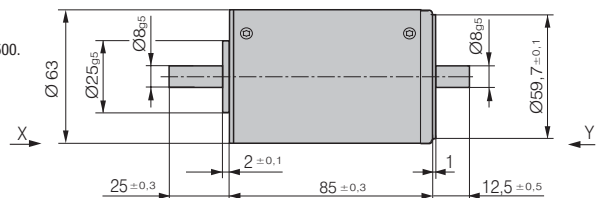

View Y Length to plug 300 min.

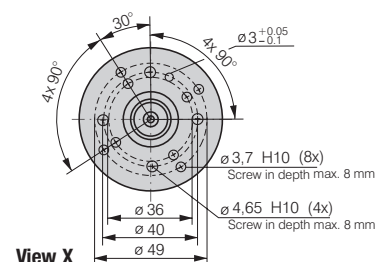

View X

ECI-Motor

ECI 63.40



- High dynamic 3-phase, 6-pulse internal rotor motor.
- EC technology.
- 4-pole rotor with inserted neodymium magnets.
- Determination of rotor position via 3 Hall sensors.
- Precision ball bearings for long service life and silent running.
- Steel housing.
- Prepared for mounting of an encoder (HEDS 5500) or a brake.
- Motor supply and control via external operating electronics.
- A-side with fixed bearing seat.

Nominal Data

Type	ECI 63.40	
Nominal voltage (U_{BN})	V DC	24
Nominal speed (n_N)	min ⁻¹	4 150
Nominal torque (M_N)	mNm	360
Nominal current (I_{BN})	A	9.2
Nominal output power (P_N)	W	160
Free-running speed (n_I)	min ⁻¹	5 600
Free-running current (I_{BL})	A	0.37
Permanent stall torque (M_{BN0})	mNm	400
Permissible eff. stall current, motor lead (I_{n0eff})	A	11.5
Permissible permanent input power at stall (P_{BN0})	W	29.0
Short-term permiss. peak torque (M_{max})	mNm	1 500
Permiss. peak current, motor lead (I_{max})	A	44
Induced voltage (U_{imax})	V/1000min ⁻¹	4.6
Terminal resistance (R_V)	Ω	0.18
Terminal inductance (L_V)	mH	0.72
Rotor moment of inertia (J_R)	kgm ² x10 ⁻⁶	16.8
Thermal resistance (R_{th})	K/W	2.65
Protection class		IP 40
Ambient temperature range (T_U)	°C	0...+40
Motor mass (m)	kg	1.4
Order No.		932 6340 001

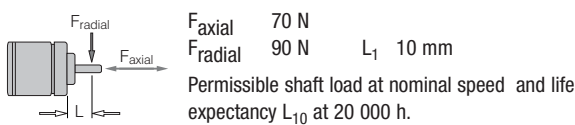

Blind holes for self threading screws according to DIN 7500.

Operating elctronics: DRIVECONTROL with analog interface.
Adapted operating electronics DRIVECONTROL VT-D: 937 6213 003

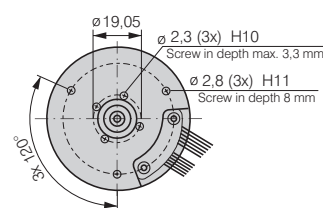
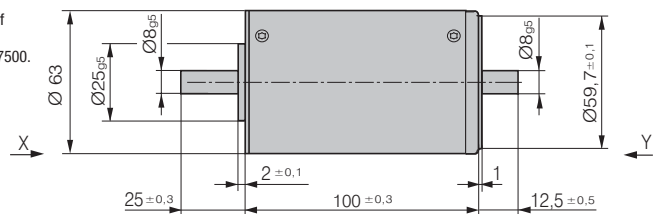
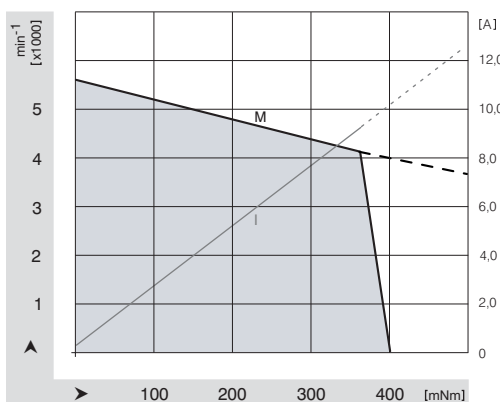

View Y Length to plug 300 min.

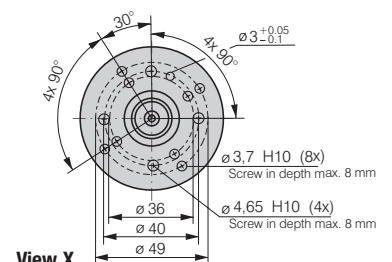

View X

ECI-Motor

ECI 63.75



- High dynamic 3-phase, 6-pulse internal rotor motor.
- EC technology.
- 4-pole rotor with inserted neodymium magnets.
- Determination of rotor position via 3 Hall sensors.
- Precision ball bearings for long service life and silent running.
- Steel housing.
- Prepared for mounting of an encoder (HEDS 5500) or a brake.
- Motor supply and control via external operating electronics.
- A-side with fixed bearing seat.

Nominal Data

Type	ECI 63.75	
Nominal voltage (U_{BN})	V DC	24
Nominal speed (n_N)	min ⁻¹	4 250
Nominal torque (M_N)	mNm	610
Nominal current (I_{BN})	A	15.5
Nominal output power (P_N)	W	270
Free-running speed (n_U)	min ⁻¹	5 600
Free-running current (I_{BL})	A	0.76
Permanent stall torque (M_{BN0})	mNm	600
Permissible eff. stall current, motor lead (I_{n0eff})	A	16.5
Permissible permanent input power at stall (P_{BN0})	W	31.0
Short-term permiss. peak torque (M_{max})	mNm	2 700
Permiss. peak current, motor lead (I_{max})	A	75
Induced voltage (U_{imax})	V/1000min ⁻¹	4.6
Terminal resistance (R_V)	Ω	0.1
Terminal inductance (L_V)	mH	0.37
Rotor moment of inertia (J_R)	kgm ² x10 ⁻⁶	26.7
Thermal resistance (R_{th})	K/W	1.85
Protection class		IP 40
Ambient temperature range (T_U)	°C	0...+40
Motor mass (m)	kg	2.1
Order No.		932 6375 001

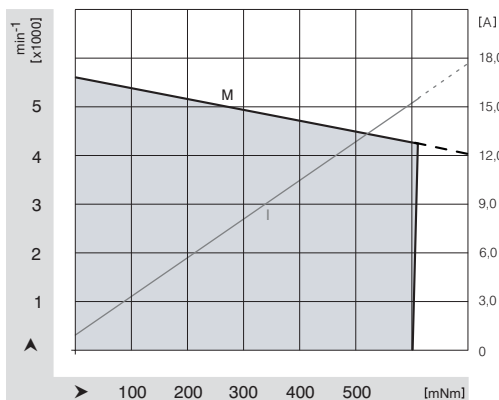
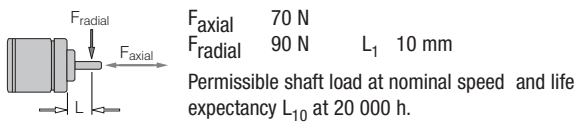

Operating electronics: DRIVECONTROL with analog interface.
 Adapted operating electronics DRIVECONTROL VT-E 20: 992 0490 020
 (optionally with limited performance data VT-D: 937 6213 003)

Blind holes for self threading screws according to DIN 7500.

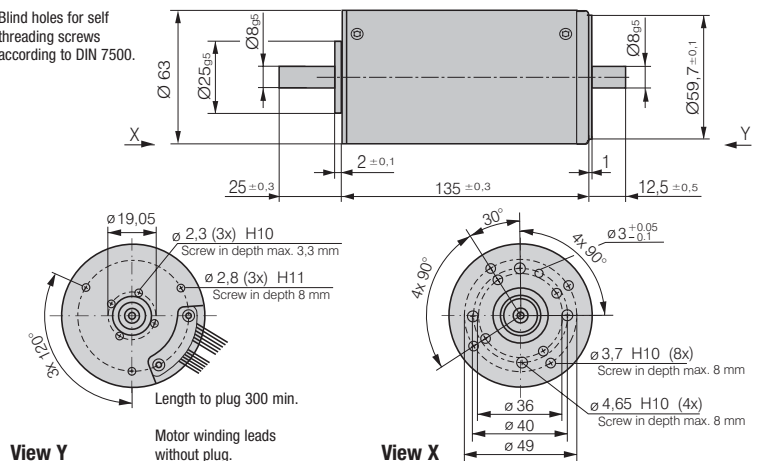

ECI Gear motor

ECI 63



- High dynamic 3-phase, 6-pulse internal rotor motor.
- EC technology.
- 4-pole rotor with inserted neodymium magnets.
- Determination of rotor position via 3 Hall sensors.
- Precision ball bearings for long service life and silent running.
- Steel housing.
- Prepared for mounting of an encoder (HEDS 5500) or a brake.
- Motor supply and control via external operating electronics.
- A-side with fixed bearing seat.

Gear data	Nominal current	Gear ratio	Stage gearbox	Nominal torque	Nominal speed	Mass	Order No. 942 6340...	Order No. 942 6375...
	A	I	Nm	min ⁻¹	kg			
ECI-63.40 PX 63-5	9.2	5:1	1	1.6	830	2.0	...001	
ECI-63.40 PX 63-30	9.2	30:1	2	8.7	138	2.3	...002	
ECI-63.75 PX 63-5	15.5	5:1	1	2.7	850	2.7		...001
ECI-63.75 PX 63-30	15.5	30:1	2	14.8	142	3.0		...002

Gear Motor PX

EC motor with 1- and 2-stage planetary gearbox.
 Robust zinc diecast housing in modular construction.
 Grease lubrication for maintenance free operation.
 Output shaft with combined sleeve- / ball bearings.
 Optimized helical gearing for long service life and quiet running in the first stage.

Type	Motor lengths		Gear length	
	L1	L2 one stage	L2 one stage	L2 two stage
ECI 63.40	100	45.8	45.8	67.2
ECI 63.75	135	45.8	45.8	67.2

Motor lead length 300 mm.
 For wire assignments, see the information on ECI motor commutation (page 4).

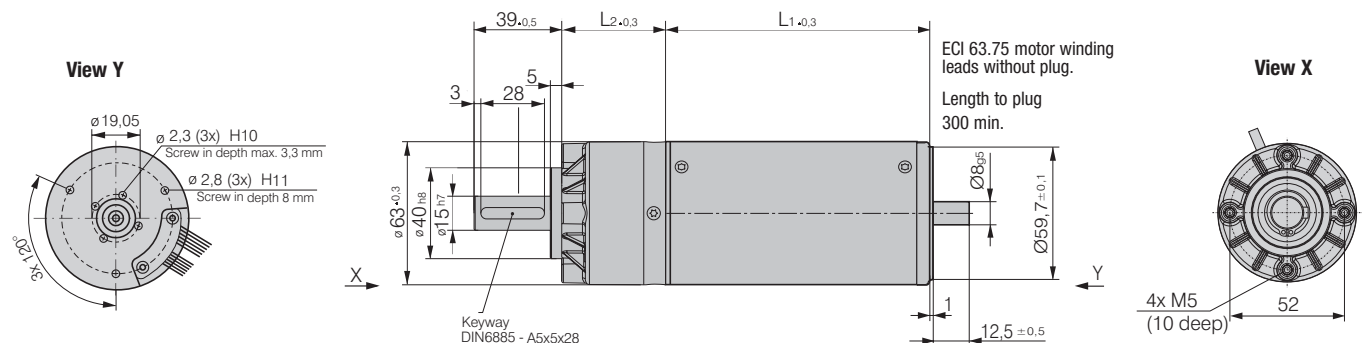

DRIVECONTROL

Series VT-D

- Operating electronics for driving 3-phase motors ECI 63.XX.
- Straight forward design in digital technology for the use as OEM electronics in series applications.
- Available in different performance levels and with adapted control characteristics for special applications.
- Only one supply voltage is required for motor and electronics.



Nominal Data

Data	Unit	Value	
Nominal voltage	V	24	24
Nominal voltage range	V	18...30	18...30
Max. output voltage	V	90% of UB	90% of UB
Output current, peak	A	7	13
Set value input		0...10 V DC	0...10 V DC
Speed control range	min ⁻¹	300...4 000	300...4 000
Speed control	Type	PI	PI
ACTUAL speed value		yes	yes
Operating temperature range	°C	0...40°C	0...40°C
Temperature monitoring		no	no
Electronics mass	kg	0.2	0.2
Function for motor protection at stall		no	no
Braking circuit		yes	yes
Protection class		IP 00	IP 00
Order No.		937 6207 002	937 6213 003

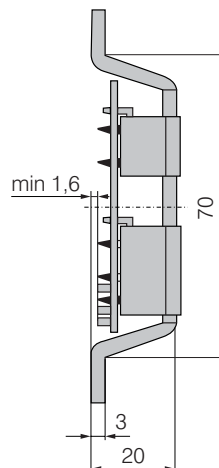
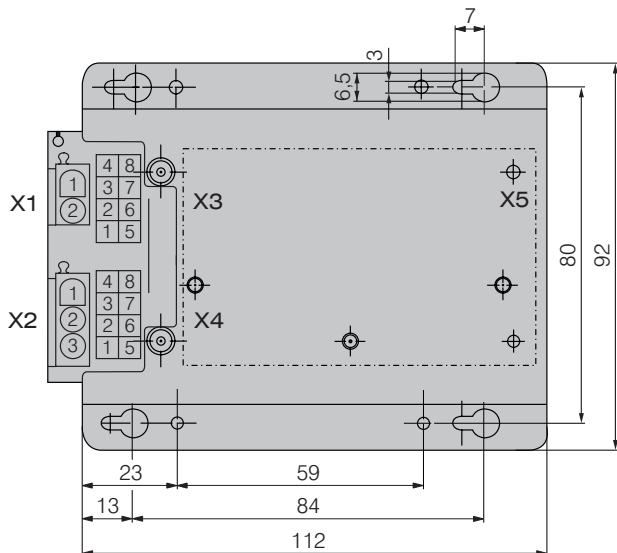

Dedicated pin configuration:

Supply X1:
194 0029 000

Control cable X3:
194 0017 001

Connector X5:

Connection for auxiliary capacitor
and braking resistor.

For detailed information please refer to
the operating manual.

ECl-Brake

24 V DC



- The spring applied brakes are single-disc brakes with two friction surfaces.
- The braking torque is generated by compression springs.
- The brake is released electromagnetically. Braking occurs when the supply voltage is switched off.
- Protection class IP 00.
- Insulation class F.

Nominal Data

Type		BFK 457-03
Nominal power*	W	9.0
Nominal torque of brake**	Nm	0.50
Engagement time	ms	12.5
Disengagement time	ms	18
Maximum speed	min ⁻¹	5 000
Mass	kg	0.40
d	mm	56.0
L1	mm	31.8
L2	mm	38.0
Motor Series***		ECl 63

* Nominal power of the coil at 20 °C.

** Nominal torque of brake, referring to a speed of 100 min⁻¹.

*** Brake for motors available on request.

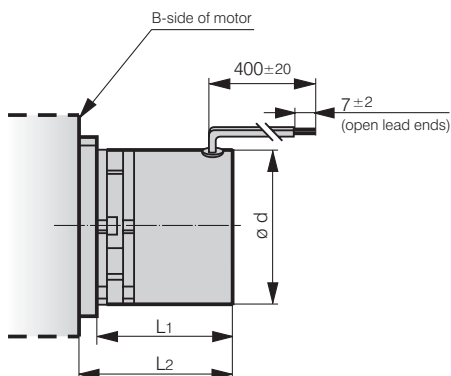

Note:

Only one accessory component (brake or sensor) can be mounted onto a motor at a time.

ECl-Sensor

Encoder HEDS 5500



- Optoelectronic 2-channel incremental encoder. A resolution of max. 2.048 increments per revolution is attained by appropriate evaluation in an external control.
- The encoder works contact-free and free from wear. The resolution of the angle of rotation is effected by means of a light-emitting diode in front of a metal encoder disc and a photo-diode array.
- Optional: Variants with other encoder resolutions are available on request.

Nominal Data



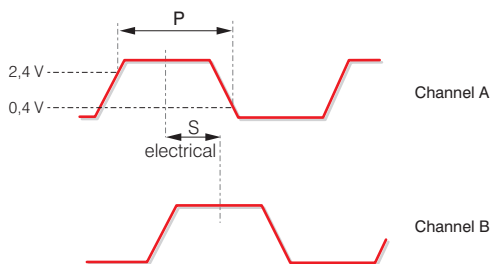

Type	HEDS 5500	
No. of pulses	Z	512 per revolution (channel A and B)
Output signal	A, B	2 rectangular-pulse signals, (90° phase offset; TTL compatible)
Limiting frequency	f	100 kHz
Supply voltage	U_B	+ 5 V \pm 10%
Current consumption	I_B	typ. 17 mA (max. 40 mA)
Deviation of pulse width	ΔP	typ. 5° related of $P = 90^\circ$ pulse width (electrically by $U_B = 5$ V and 25° C)
Deviation of phase shift	ΔS	typ. 7° related of $S = 90^\circ$ phase shift between channel A and B (electrically by $U_B = 5$ V and 25° C)
Electrical connection	AMP	103686-4 or 600442-5
Plug type	Berg	65039-032 / 4825-000
	Molex	or 65801-034 2695 / 2759
Connection table	Pin	1: Ground 2: free 3: A 4: U_B 5: B

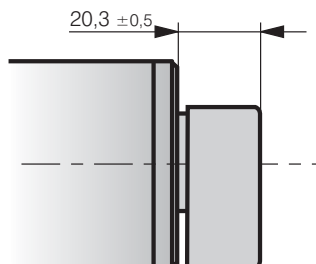
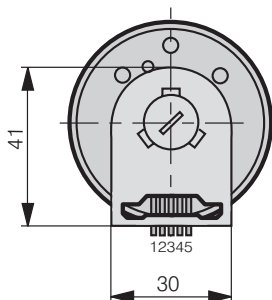

Motors with HEDS available on request!



Note:
Only one accessory component (brake or sensor) can be mounted onto a motor at a time.

-  Motors Distributors
-  spec. Motors Distributors
-  Fans Distributors
-  Ventilator Distributors

Distributors of ebm-papst

Germany

ebm-papst St. Georgen GmbH & Co. KG

Hermann-Papst-Straße 1
D-78112 St. Georgen
Phone +49 (0) 77 24 / 81 - 0
Fax +49 (0) 77 24 / 81 - 13 09
info2@de.ebmpapst.com

www.ebmpapst.com

ebm-papst Muldingen GmbH & Co. KG

Bachmühle 2
D-74673 Muldingen
Phone +49 (0) 79 38 / 81 - 0
Fax +49 (0) 79 38 / 81 - 110
info1@de.ebmpapst.com

www.ebmpapst.com



ebm-papst Landshut GmbH

Hofmark-Aich-Straße 25
D-84030 Landshut
Phone +49 (0) 8 71 / 707 - 0
Fax +49 (0) 8 71 / 707 - 465
info3@de.ebmpapst.com

www.ebmpapst.com

Agencies

Berlin

-  Dipl.-Ing. (TH) Jens Duchow
-  Händelstraße 7
-  16341 Panketal
- Phone +49 (0) 30 / 94 41 49 62
- Fax +49 (0) 30 / 94 41 49 63
- Jens.Duchow@de.ebmpapst.com

Dortmund

-  Dipl.-Ing. (FH) Hans-Joachim Pundt
-  Auf den Steinern 3
-  59519 Möhnese-Völlinghausen
- Phone +49 (0) 29 25 / 80 04 07
- Fax +49 (0) 29 25 / 80 04 08
- Hans-Joachim.Pundt@de.ebmpapst.com



Frankfurt

-  Dipl.-Ing. Christian Kleffmann
-  Dr. Hermann-Krause Straße 23
-  63452 Hanau
- Phone +49 (0) 61 81 / 18 98 12
- Fax +49 (0) 61 81 / 18 98 13
- Christian.Kleffmann@de.ebmpapst.com



Halle

-  Dipl.-Ing. (TU) Michael Hanning
-  Lerchenweg 4
-  06120 Lieskau
- Phone +49 (0) 3 45 / 5 51 24 56
- Fax +49 (0) 3 45 / 5 51 24 57
- Michael.Hanning@de.ebmpapst.com

Hamburg

-  Ingenieurbüro Breuell GmbH
-  Elektro.-Ing. Dirk Kahl
-  Grützmühlenweg 40
- 22339 Hamburg
- Phone +49 (0) 40 / 53 80 92 10
- Fax +49 (0) 40 / 53 80 92 84
- Dirk.Kahl@de.ebmpapst.com

Kassel

-  Dipl.-Ing. (FH) Ralph Brück
-  Hoherainstraße 3 b
-  35075 Gladenbach
- Phone +49 (0) 64 62 / 40 71 10
- Fax +49 (0) 64 62 / 40 71 11
- Ralph.Brueck@de.ebmpapst.com



Koblenz

-  Winfried Schaefer
-  Hinter der Kirch 10
-  56767 Uersfeld
- Phone +49 (0) 26 57 / 16 96
- Fax +49 (0) 26 57 / 16 76
- Winfried.Schaefer@de.ebmpapst.com



München

-  Dipl.-Wirt.-Ing. (FH) Jens Peter
-  Steinbergweg 6
-  82285 Hattenhofen
- Phone +49 (0) 81 45 / 80 92 25
- Fax +49 (0) 81 45 / 80 92 26
- Jens.Peter@de.ebmpapst.com

Nürnberg

-  Friedrich Klein
-  Adlerstraße 49/1
-  73540 Heubach
- Phone +49 (0) 71 73 / 49 83
- Fax +49 (0) 71 73 / 80 53
- Friedrich.Klein@de.ebmpapst.com



Offenburg

-  Dipl.-Ing (FH) Ralf Braun
-  Hubeneck 21
-  77704 Oberkirch
- Phone +49 (0) 78 02 / 98 22 52
- Fax +49 (0) 78 02 / 98 22 53
- Ralf.Braun@de.ebmpapst.com

Stuttgart

-  Dipl.-Ing. (FH) Rudi Weinmann
-  Mühlhaldenweg 13
-  73207 Plochingen
- Phone +49 (0) 71 53 / 92 89 80
- Fax +49 (0) 71 53 / 92 89 81
- Rudi.Weinmann@de.ebmpapst.com

Ulm



-  Günter Wilhelm
-  Allgäuer Str. 7
-  89269 Vöhringen
- Phone +49 (0) 73 06 / 92 46 08
- Fax +49 (0) 73 06 / 92 46 48
- Guenter.Wilhelm@de.ebmpapst.com

External Support Manager drive engineering

Office East

-  Dipl.-Ing. (TU) Michael Hanning
- Lerchenweg 4
- 06120 Lieskau bei Halle
- Phone +49 (0) 3 45 / 5 51 24 56
- Fax +49 (0) 3 45 / 5 51 24 57
- Michael.Hanning@de.ebmpapst.com

Office North

-  Ingenieurbüro Breuell GmbH
-  Elektro.-Ing. Dirk Kahl
-  Grützmühlenweg 40
- 22339 Hamburg
- Phone +49 (0) 40 / 53 80 92 55
- Fax +49 (0) 40 / 53 80 92 84
- Dirk.Kahl@breuell.de

Office West

-  Matthias Bembenek
- Prozessionsweg 39
- 46286 Dorsten
- Phone +49 (0) 23 69 / 20 82 05
- Fax +49 (0) 23 69 / 20 82 07
- Matthias.Bembenek@de.ebmpapst.com

Office South-West

-  Thomas Schrag
- Mahlbergstr. 37/1
- 75210 Kelttern
- Phone +49 (0) 72 36 / 98 24 07
- Fax +49 (0) 72 36 / 98 24 09
- Thomas.Schrag@de.ebmpapst.com



Office South-Ost

-  Jürgen Sopejstal
- Kirchhoffstr. 26
- 90552 Röthenbach
- Phone +49 (0) 9 11 / 5 44 38 15
- Fax +49 (0) 9 11 / 5 44 38 16
- Juergen.Sopejstal@de.ebmpapst.com

Express Service-Center





Service and Consulting Center for sales of small quantities.

North

-  Breuell + Hilgenfeldt GmbH
-  Grützmühlenweg 40
-  22339 Hamburg
- Phone +49 (0) 40 / 53 80 92 20
- Fax +49 (0) 40 / 53 80 92 84
- ebmpapst@breuell.de

Europe

Austria

-  ebm-papst Motoren & Ventilatoren GmbH
-  Westbahnstr. 5
-  A-4490 Florian
- Phone +43 / 7224 / 66 011-0
- Fax +43 / 7224 / 66 011-20
- info@at.ebmpapst.com; www.ebmpapst.at
-  next system
- Vertriebsges. m.b.H.
- Dresdner Str. 68/1/3
- A-1200 Wien
- Phone +43 / 1 / 33 166-0
- Fax +43 / 1 / 33 166-100
- office@nextsystem.at; www.nextsystem.at

ebm-papst
St. Georgen GmbH & Co. KG

Hermann-Papst-Straße 1
D-78112 ST. GEORGEN
Germany
Phone +49 (0) 7724 / 81-0
Fax +49 (0) 7724 / 81-1309
info2@de.ebmpapst.com

www.ebmpapst.com

ebm-papst
St. Georgen GmbH & Co. KG

Hermann-Papst-Straße 1
D-78112 ST. GEORGEN
Germany
Phone +49 (0) 7724 / 81-0
Fax +49 (0) 7724 / 81-1309
info2@de.ebmpapst.com

www.ebmpapst.com